

TRACER ASSEMBLY INSTRUCTIONS

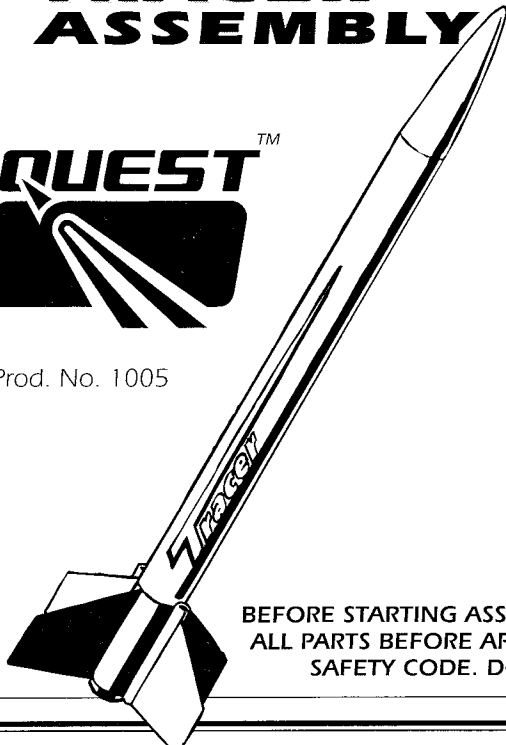

Prod. No. 1005



Things You'll Need To Assemble this Kit:

Hobby Knife 

Pencil 

White Glue

Aliphatic Resin glues work best such as TITEBOND or ELMER'S CARPENTER'S WOOD GLUE - ELMER'S WHITE SCHOOL GLUE also works but dries slower.



Plastic Cement

Use TESTORS TUBE Plastic Cement, PACTRA LIQUID CEMENT or other comparable brands. DO NOT use cyanoacrylate glue.



Tape

Scotch Magic Tape or Paper Masking Tape



BEFORE STARTING ASSEMBLY READ THROUGH THESE INSTRUCTIONS. IT IS BEST TO TEST FIT ALL PARTS BEFORE APPLYING ANY GLUE. READ AND FOLLOW THE N.A.R. MODEL ROCKET SAFETY CODE. DO NOT USE CYANOACRYLATE GLUE TO ASSEMBLE THIS MODEL.

PARTS LIST

- A. 49000 Motor Clip
- B. 14000 Blue Thrust ring
- C. 10301 Yellow Motor Mount Tube
- D. 14050 Red Centering Ring (2)
- E. 21551 Plastic fin Unit
- F. 11304 Body Tube
- G. 20100 Plastic Nose Cone
- H. 20101 Nose Cone Base
- I. 50050 12 inch Kevlar* Shock Cord
- J. 50011 18 inch White Elastic Shock Cord
- K. 28102 12" Parachute
- L. 50100 Pack of 3-26" Shroud Lines
- M. 28001 Strip of 6 GRIPPER Tabs
- N. 91010 Self-adhesive Decal
- O. 90061 Instruction Sheet

*Kevlar is a registered trademark of Dupont

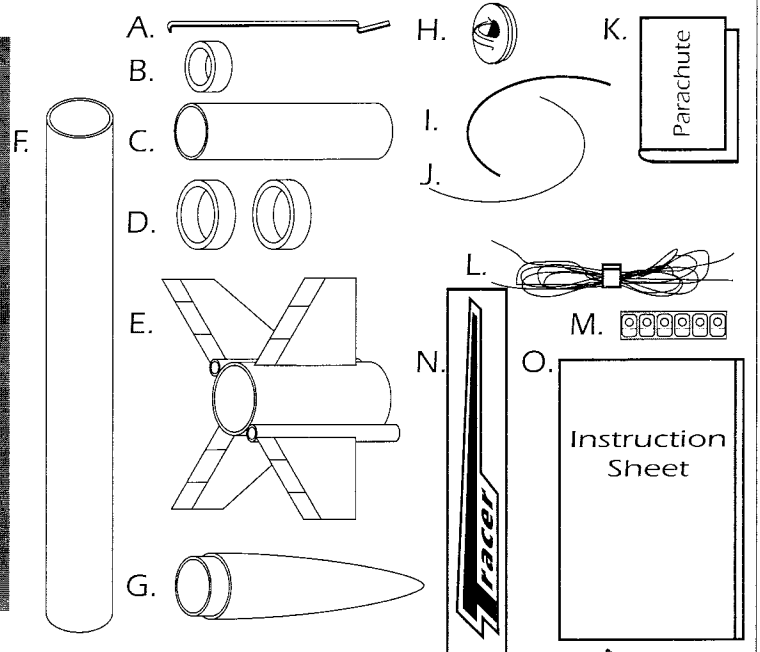

STEP 1

A. Apply plastic model cement (NOT WHITE GLUE) around the inside edge of the plastic nose cone. Push the base into the nose cone. Set aside to dry.

Plastic Model Cement

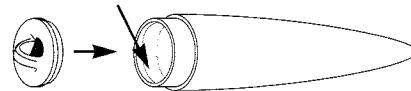

B. Place the Blue Thrust Ring up against the side of the Yellow Motor Mount Tube and use it as a guide to make a small 1/8 inch long slit in the side of the Yellow Motor Mount Tube as shown.

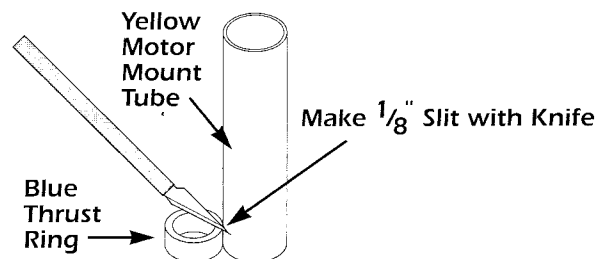

0 INCHES
1
2
3
4
5
6
7
8
9
10

STEP 2

- Make a slight bend in the Motor Clip as shown. Insert the Motor Clip into the slit you made in the Yellow Motor Mount Tube.
- Test fit one of the Red Centering Rings onto the Yellow Motor Mount Tube. If it does not slide on easily, stretch the Red Ring by sliding it over the Nose Cone and gently twisting it back and forth a few times. Slide the Red Ring onto the Yellow Tube just far enough to hold the Motor Clip in place.

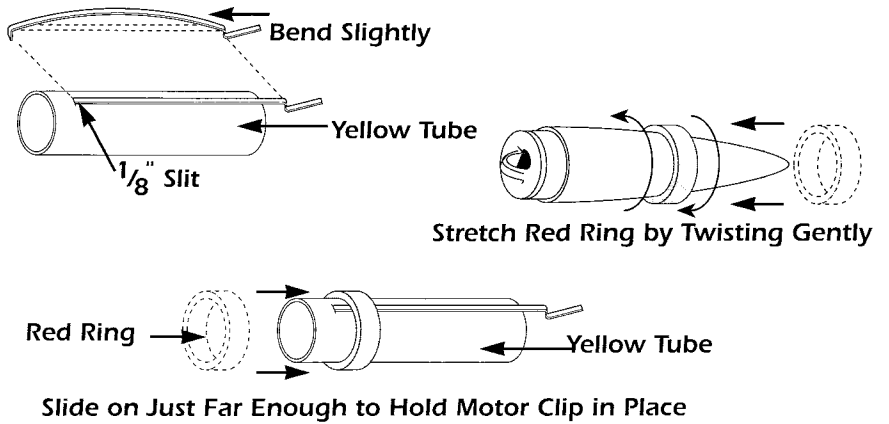

STEP 3

- Apply a bead of white glue around the Yellow Motor Mount Tube 1/2 inch from the end as shown.
- Slide the Red Ring into the bead of glue. Wipe away any excess glue.

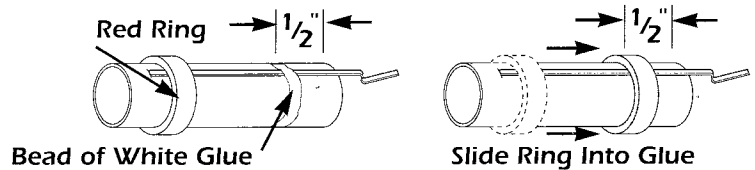

STEP 4

- Tie two overhand knots 1 inch in from the end of the Yellow Kevlar Cord.
- Pass the end of the Kevlar with the knot through the remaining Red Centering Ring.
- Slide the Red Centering ring with the Kevlar under it onto the Yellow Motor Mount Tube.

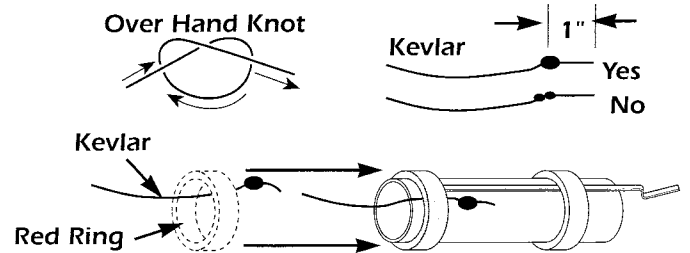

STEP 5

- Apply a bead of white glue around the Yellow Motor Mount Tube 1/2 inch from the end as shown.
- Slide the Red Ring into the bead of glue. Wipe away any excess glue.
- Pull the Yellow Kevlar Shock Cord up tight against the Red Centering Ring.

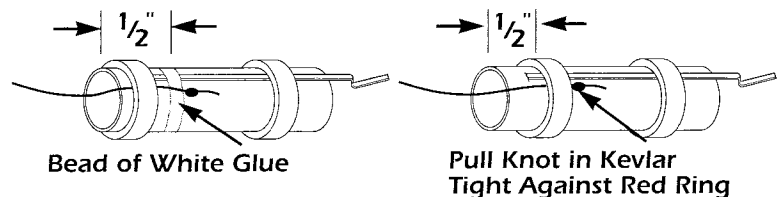

STEP 6

- Apply white glue around inside edge of Yellow Motor Mount Tube as shown.
- Insert the Blue Thrust Ring into the Yellow Motor Mount Tube so it is even with the end of the Yellow Motor Mount Tube.

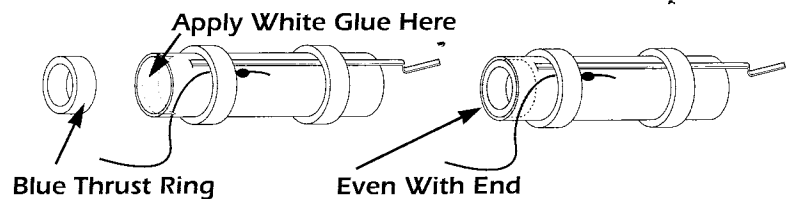

STEP 7

- Hold the Yellow Kevlar Shock Cord and the White Elastic Shock Cord side by side. Pull one end of each cord so that they are even with each other. While holding the two cords together, tie a single parallel overhand knot approximately one inch in from the even ends as shown.
- Gently pull on both cords to set the knot and prevent it from slipping.
- Apply a small amount of white glue on the ends of both cords to prevent them from fraying.

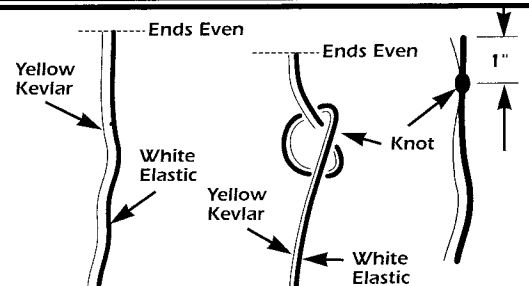

NOTE: THIS IS A VERY IMPORTANT STEP. IF YOU TIE A DIFFERENT TYPE OF KNOT THE SHOCK CORDS MAY SEPARATE DURING FLIGHT.

STEP 8

- Stretch one end of the Body Tube slightly by inserting the nose cone into the tube and gently twisting it back and forth a few times.
- Hold the Body tube with the stretched end facing up and "feed" the shock cord into the tube until the cord comes out the other end.
- Grab the end of the shock cord and pull it all the way through the tube until the Motor Mount Assembly that is attached to the other end pulls up against the tube.

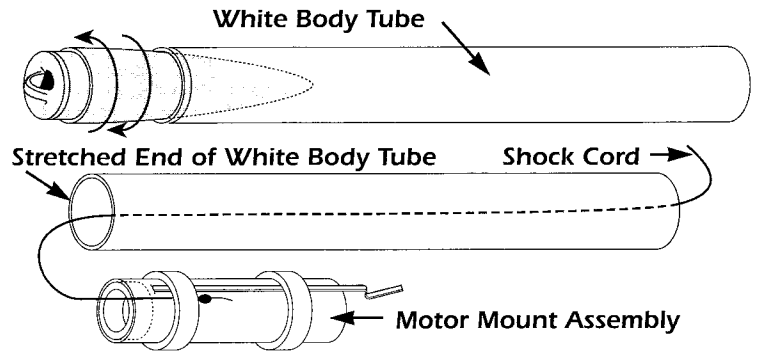

STEP 9

- Hold the Motor Mount Assembly and the Body Tube in one hand.
- Apply White Glue around the inside of the Body Tube.
- Immediately insert the Motor Mount Assembly and PUSH IT INTO THE BODY TUBE WITH ONE FAST & SMOOTH MOTION until the Yellow Motor Mount Tube is even with the end of the Body Tube.

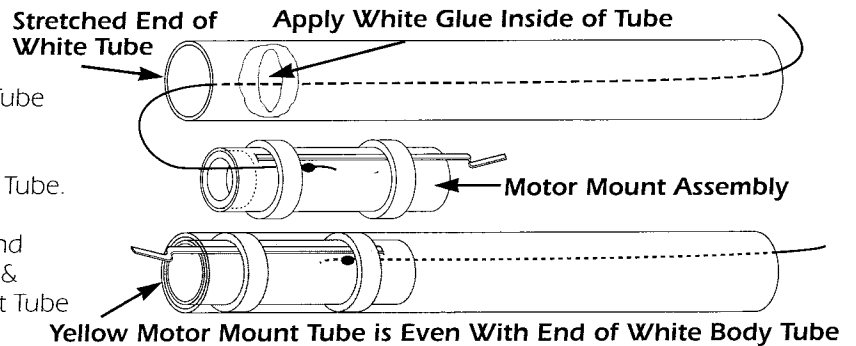

STEP 10

- Slide the One-Piece Molded Plastic Fin Unit onto the body tube as shown.
 - Slide the fin unit forward about 2 inches and wrap a 2 inch piece of Scotch magic tape or a 1 inch piece of masking tape around the outside end of the body tube.
 - Use a slight twisting motion to slide the fin unit back over the tape and even with the end of the White Body Tube.
- NOTE:** Fin Unit must fit snugly and should be difficult to move once it is in place. Add or remove tape to get the correct fit.

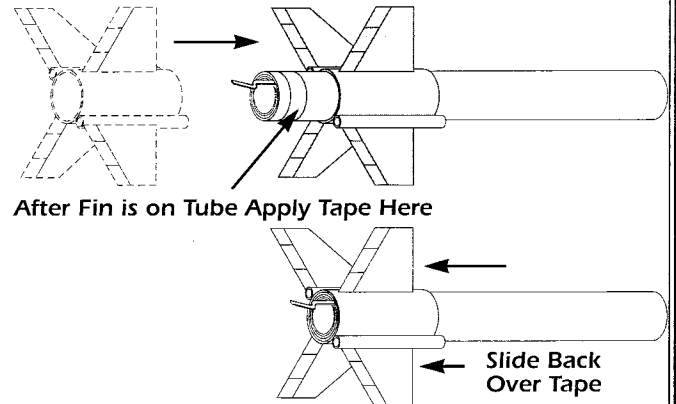

STEP 11

- Assemble the parachute according to the instructions printed on it.
- Firmly squeeze each gripper tab and parachute between your fingers.

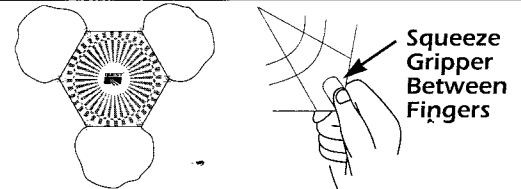

STEP 12

- Use two overhand knots to tie the loose end of the shock cord onto the base of the nose cone.
- Pass the shroud line loops through the eyelet on the nose cone. Pass parachute through loop ends and pull lines tightly against the eyelet.
- If the nose cone fits too loose, wrap a short piece of tape around the shoulder of the nose cone until you get a snug but not tight fit.

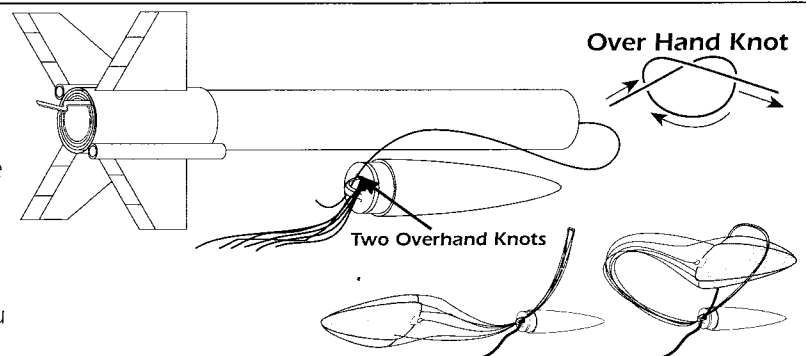

STEP 13

- Remove decal slowly from the backing to prevent decal from curling over onto itself. Once decal is removed from backing, hold decal at each end while placing it into position.
- NOTE:** Use caution when removing the decal from the backing to prevent decal from curling over onto itself.

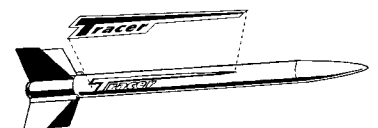

FLYING YOUR ROCKET

WHAT ELSE YOU WILL NEED:

To successfully fly your rocket you will need the following items:

- QUEST Launch Pad (No. 7600)
- QUEST Launch Controller (No. 7500)
- QUEST Parachute Recovery Wadding (No. 7020)
- QUEST Rocket Motors, Type A6-4, B6-4, C-5, or C6-7
- Use a A6-4 Motor for your first flights.

ESTIMATED ALTITUDES

The following is a guide to assist you in determining which motor to use based on the wind conditions and size of flying field available.

| MOTOR | ESTIMATED ALTITUDE |
|-------|--------------------|
| A6-4 | 250 FEET |
| B6-4 | 450 FEET |
| C6-5 | 1000 FEET |
| C6-7 | 1100 FEET |

PREPPING YOUR ROCKET FOR FLIGHT

STEP 1

Pull the shock cord all the way out of the body tube. Crumple three sheets of recovery wadding and insert one by one into the body tube making sure that the Knot between the Kevlar and white elastic shock cord is on the nose cone side of the wadding. Wadding should fit loosely in the tube but tight enough to form a good seal against the wall of the body tube.

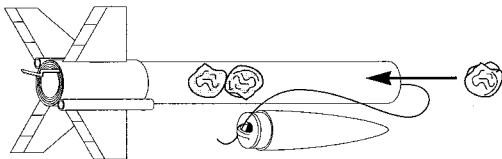

STEP 2

- Grab the parachute at its center and allow the rocket to hang from it. The weight of the rocket will pull the parachute into several triangular shapes.
- Gather the triangles together into one flat triangle.
- Fold the top of the parachute down over itself once.
- Now continue to roll the parachute over itself and roll the shroud lines around it.

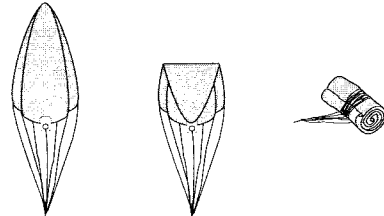

STEP 3

- Pack the parachute into the body tube. **THE PARACHUTE MUST SLIDE EASILY INTO THE TUBE.** If it is a tight fit, remove and re-fold the parachute.
TIP: LIGHTLY DUST YOUR PARACHUTE WITH TALCUM OR BABY POWDER TO KEEP IT FROM DEVELOPING A SET SHAPE. THIS TECHNIQUE IS ESPECIALLY EFFECTIVE IF THE WEATHER IS HOT AND HUMID OR VERY COLD.
- Push the shock cord into the tube and re-fit the nose cone onto the rocket. **BE CAREFUL NOT TO CATCH ANY OF THE SHOCK CORD BETWEEN THE SHOULDER OF THE NOSE CONE AND THE BODY TUBE.**

READ AND FOLLOW THE ENCLOSED LAUNCHING PROCEDURE SHEET

READ AND FOLLOW THE N.A.R. SAFETY CODE DURING ALL YOUR MODEL ROCKETRY ACTIVITIES.



IRONCLAD GUARANTEE

If for any reason, you are not totally satisfied with our product, QUEST will provide whatever you think is fair, from refund to replacement.



Manufactured by:
QUEST AEROSPACE
EDUCATION, INC.
Distributed Exclusively by:
HOBBICO, INC.
1610 INTERSTATE DRIVE
CHAMPAIGN, IL 61821



QUEST
AEROSPACE
EDUCATION, INC.
Phoenix, AZ 85027-2921 U.S.A.

LAUNCHING PROCEDURES

This sheet covers basic Launching Procedures for single stage model rockets with parachute or streamer recovery systems. Review your kit instructions for additional information about your model rocket. Specific details for launching multi-stage models, glider recovery vehicles or other different types of model rockets are featured in the instructions of specific kits.

TIGERTAIL IGNITER INSTALLATION

Launch your model rockets by electrical means only. Use a Quest Launch Controller and TigerTail Igniters. Install TigerTail Igniter carefully, following these instructions.

STEP 1 Remove Black Die-Cut Dots as Shown

A) Carefully remove self-adhesive TigerTail sticker from its backing sheet.

B) Remove the two die-cut black dots from the TigerTail sticker.

C) Wrap the "T" shaped end of the TigerTail sticker around the nozzle end of the rocket motor.

D) Bend sticker to the side away from the rocket motor.

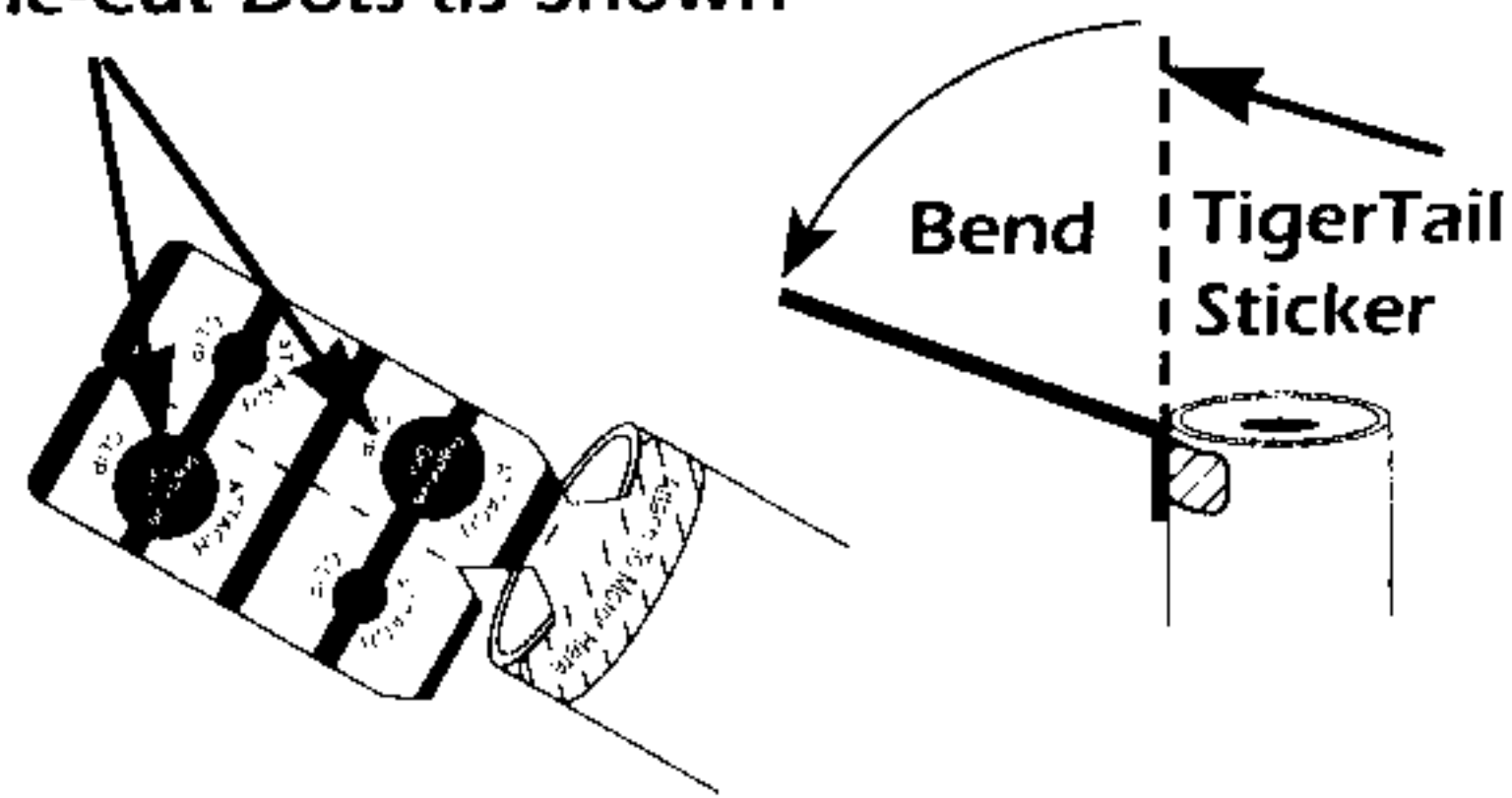

E) Place the coated end of the copper igniter wire into the rocket motor nozzle, as far as it will go.

STEP 2

A) Using your finger to hold the igniter in place, bend the copper igniter wire onto the adhesive surface of the TigerTail sticker, centered over the hole as shown.

B) Fold TigerTail sticker over and onto the copper igniter wire. Be sure the copper igniter wire is centered and visible through both holes in the TigerTail sticker.

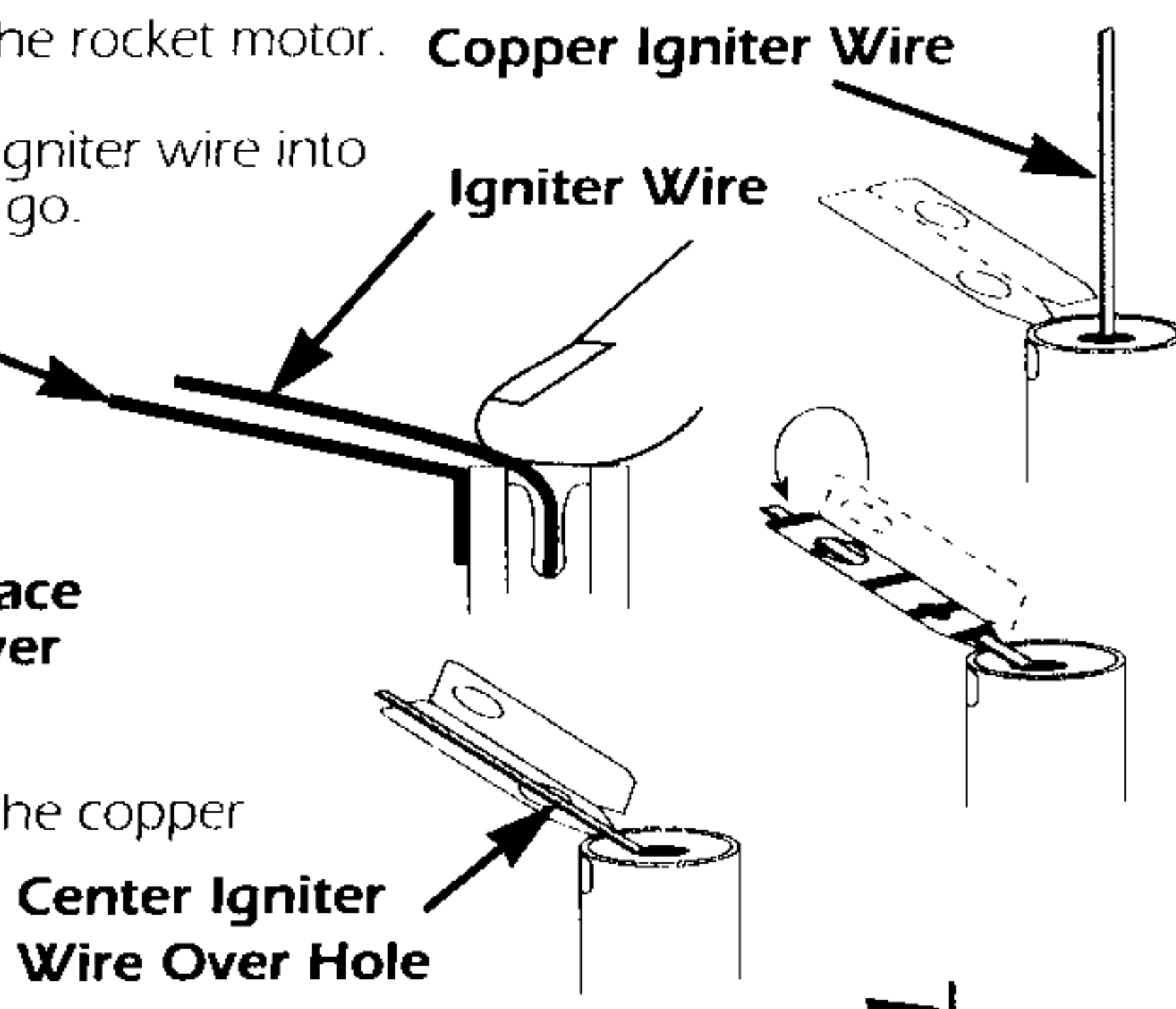

STEP 3

A) Using your finger to hold copper igniter wire against motor nozzle, straighten the TigerTail Igniter as shown.

B) Place rocket motor with TigerTail Igniter into the motor mount of the rocket.

C) For best results DO NOT place motor mount clip over TigerTail Igniter.

STEP 4

A) ANCHOR THE LAUNCH CONTROLLER'S MICRO-CLIP LEADS TO THE LAUNCH PAD BY ATTACHING THEM TO A LAUNCH PAD LEG USING A SINGLE OVERHAND KNOT. This prevents micro-clip leads from easily pulling away from the launch pad.

B) Micro-clip lead wire should also be pulled apart so each individual micro-clip lead is 6" to 8" long.

C) Attach one micro-clip lead from the launch controller to each hole, where the copper igniter wire is exposed, on the TigerTail Igniter. For best results bring one micro-clip lead around each side of the Launch Rod Stand-Off tube before hooking up to TigerTail Igniter.

D) Be sure TigerTail Igniter points straight down under rocket motor nozzle when micro-clip leads are attached. Micro-clips should be positioned on opposite sides of the TigerTail Igniter.

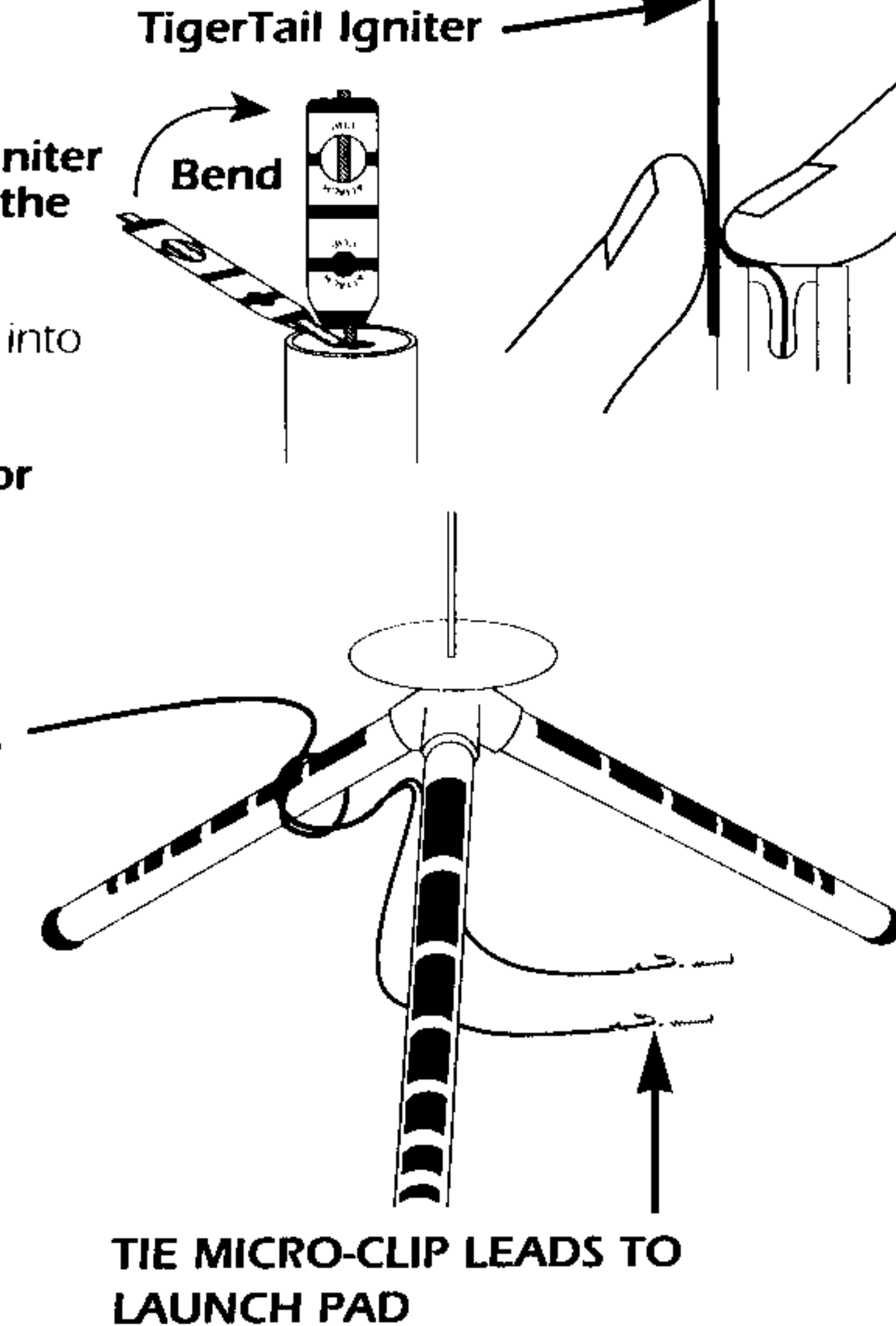

TIE MICRO-CLIP LEADS TO LAUNCH PAD

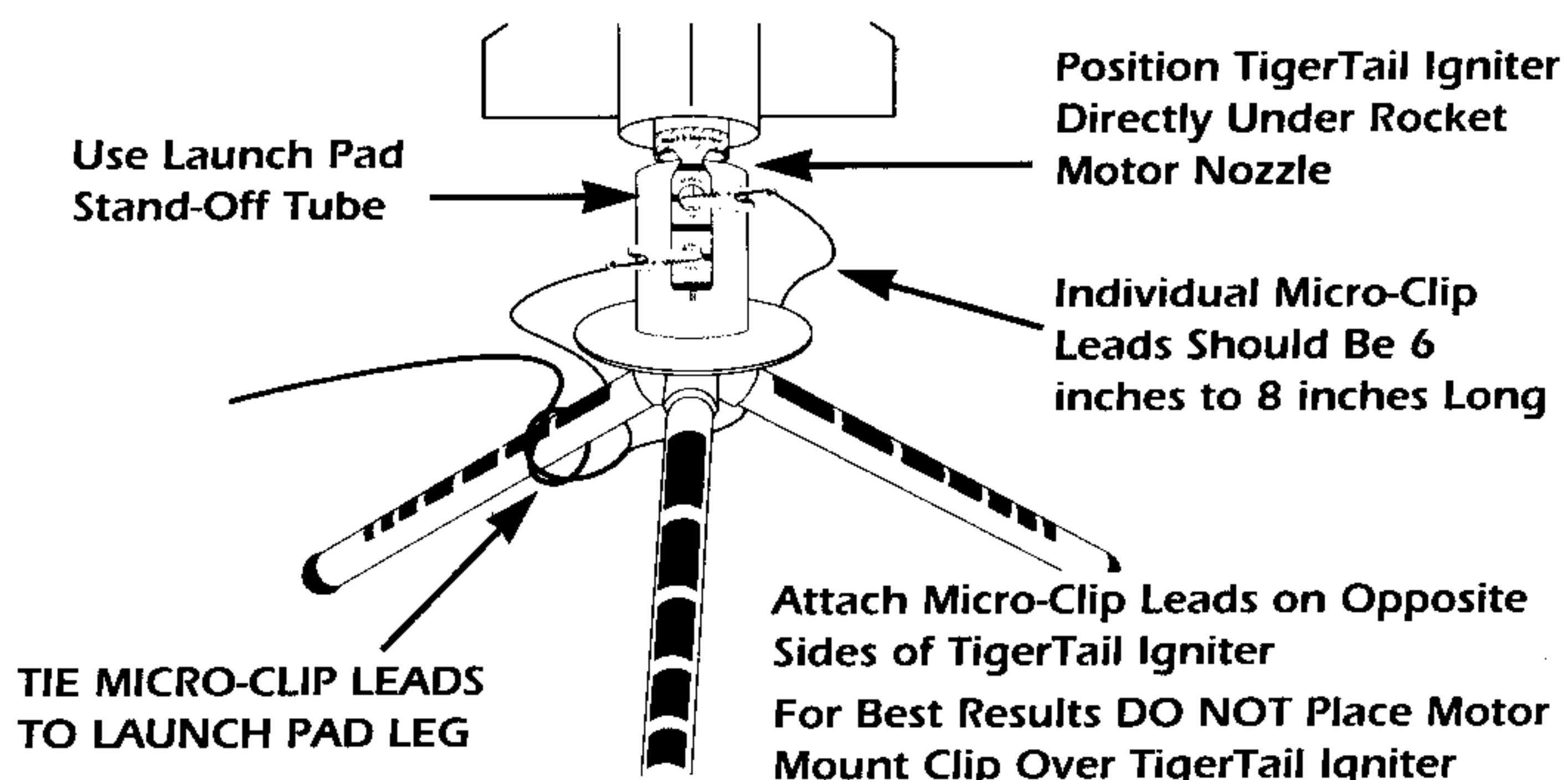

Use Launch Pad Stand-Off Tube

Position TigerTail Igniter Directly Under Rocket Motor Nozzle

Individual Micro-Clip Leads Should Be 6 inches to 8 inches Long

Attach Micro-Clip Leads on Opposite Sides of TigerTail Igniter For Best Results DO NOT Place Motor Mount Clip Over TigerTail Igniter

LAUNCH SITE SELECTION: Select a large area away from tall trees, power lines and low flying aircraft. Parks, playgrounds, soccer and football fields make great launch sites. DO NOT LAUNCH ROCKETS IN AREAS WITH BROWN GRASS, DRY WEEDS, OBSTRUCTIONS OR ANY HIGHLY FLAMMABLE MATERIALS. The larger the launch site the easier it will be to recover your rocket. See the N.A.R. Safety Code for additional information.

Motor Type Minimum Site Dimensions (feet)

| | |
|---|-----|
| A | 100 |
| B | 200 |
| C | 400 |

LAUNCH PREPARATIONS: (1) Parachute Recovery Wadding should be positioned between the rocket motor and the recovery system to prevent scorching of the parachute or streamer. The wadding should loosely fill the body tube for a depth of approximately two body tube diameters. Crumble the wadding loosely to get maximum bulk and a good seal against the wall of the body tube. See Recovery Wadding instructions for more information.

(2) Recheck the recovery system of your model to be sure it has been prepped and packed per its instructions. Your parachute or streamer should fit loosely inside the rocket's body tube so it can deploy easily. Lightly dust your parachute with baby or talcum powder to keep it from developing a set shape inside your rocket body tube. This technique is especially effective if the weather is hot and humid or is very cold.

(3) Check the nose cone fit to be sure it's snug, but not too tight. If it's too loose add a small piece of tape to the shoulder of the nose cone. If it's too tight lightly sand the shoulder of the nose cone and/or stretch the end of the body tube slightly by inserting the pointed end of the nose cone into the body tube and gently twist it back and forth a few times.

(4) To select the correct rocket motor consult the current Quest Catalog, product packaging or instruction sheet for recommended rocket motors to use in your model. Follow all igniter and rocket motor installation procedures.

(5) Install the TigerTail Igniter into the rocket motor per the TigerTail Igniter instructions.

(6) When placing the rocket motor into the easy-lock motor mount be sure the motor mount clip is securely positioned over the end of the rocket motor. **For best results DO NOT place the motor mount clip over the tigertail igniter.**

(7) Unwind the wire leads from your Launch Controller and place the controller the full length of the wire leads away from the launch pad (at least 15 feet). Be sure the launch controller is disarmed and is in good working condition. Micro-clips must be clean. **ATTACH THE CONTROLLER'S MICRO-CLIP LEADS TO THE LAUNCH PAD BY TYING THEM TO ONE OF THE LAUNCH PAD LEGS WITH A SINGLE OVER HAND KNOT.** Micro-clip lead wire should be pulled apart so each individual micro-clip lead is 6 inches to 8 inches long.

(8) ALWAYS USE CAUTION WHEN BENDING OVER YOUR LAUNCH PAD TO AVOID EYE INJURY. Remove the launch rod safety cap and lower the rocket onto the launch pad positioning it on the Launch Rod Stand-Off several inches above the blast deflector. The launch lug on the rocket's body tube should glide easily over the launch rod. Check be sure there are no rough surfaces or obstructions on the launch rod which could hinder the lift-off of the model. For eye safety keep the tip of the launch rod covered with the Launch Rod Safety Cap until you are just ready to begin the countdown.

(9) Be sure the Safety Key is with you before hooking up the micro-clips to the TigerTail Igniter. Attach one micro-clip lead to each hole in the TigerTail Igniter where the copper wire is exposed. The micro-clips MUST NOT touch each other or the blast deflector. Use the Launch Rod Stand-Off, an empty motor casing or piece of tape wrapped around the launch rod to position the rocket several inches above the blast deflector to keep the micro-clips from touching it and shorting out. For best results bring one micro-clip lead around each side of the Launch Rod Stand-Off and the hook up to TigerTail Igniter.

COUNT DOWN PROCEDURE: (1) When your rocket is ready to launch be sure you and all spectators are standing at least 15 feet away from the launch pad. (2) Make sure the sky is clear of low flying aircraft. Wind conditions should be gentle. Be sure you have the attention of all individuals in the launching and recovery areas. (3) Arm your Launch Controller with the Safety Key. The arming light should go on. If arming light does not go on check battery power, electrical connections and igniter installation. Clean micro-clips with sand paper if necessary. (4) With rocket armed announce to the spectators in a loud voice, "the rocket is armed, and counting...5...4...3...2...1...Lift-Off!" (5) Push the launch button down momentarily until the rocket motor begins thrusting, then release it. The rocket should lift-off from the launch pad almost instantly. (6) **BE SURE AND REMOVE THE SAFETY KEY FROM THE LAUNCH CONTROLLER AS SOON AS THE ROCKET LIFTS-OFF. KEEP THE SAFETY KEY WITH YOU AT ALL TIMES.** (7) **REPLACE THE LAUNCH ROD SAFETY CAP IN BETWEEN LAUNCHINGS.**

RECOVERY PROCEDURE: (1) Track the flight of your rocket until the recovery system is deployed and the rocket is returning gently back to Earth. (2) If the rocket appears to be drifting away from the launch area keep your eyes on it until it touches down. (3) If the recovery system malfunctions be prepared to alert the spectators that the rocket is returning to Earth faster than normal and to be "heads-up" and aware of the area where the rocket is falling to.

MISFIRE PROCEDURE: (1) Occasionally, at the end of the countdown the rocket will fail to lift-off because the rocket motor did not ignite. This usually occurs because the igniter was not making the proper contact with the surface of the rocket motor's propellant. (2) Disarm the launch controller, wait one minute, then remove the model from the launch pad. (3) Remove the TigerTail sticker from the end of the motor casing, clean the micro-clips and install a new TigerTail Igniter. (4) Repeat countdown procedure again. (5) **IF TIGERTAIL IGNITER TEARS APART, DO NOT ATTEMPT TO REPAIR. REPLACE WITH A NEW TIGERTAIL IGNITER.**

BATTERY TEST: If batteries are weak replace them. Battery strength can be tested by attaching both micro-clips together and inserting the Safety Key. The arming light should glow brightly. Batteries are weak if light is dim. **Be sure to use alkaline type batteries for best results.**