

# Estes Industries Technical Report TR-6

## Cluster Techniques for Model Rockets

These reports are published as a service to its customers by Estes Industries, Inc., Box 227, Penrose, Colorado. Copyright 1963 by Estes Industries, Inc.

A common technique in the development of rockets to carry large payloads is the use of a cluster of smaller engines to obtain a high thrust level. Typical of this method are NASA's Little Joe, Saturn, and Nova launch vehicles.

Clustering can be used with model rockets to give excellent results. However, if this method is to be used successfully, the rocketeer must use the right techniques and apply them correctly.

Experience has shown that with present techniques clusters of more than 4 engines are not practical. While rockets using more engines have been flown, they are not very reliable. The techniques described in this report have been developed and used almost entirely for clusters of three engines. These methods may, however, be adapted to 2 or 4 engines without too much difficulty.

### IGNITION

One of the first questions a rocketeer asks when he starts learning about clustering is "How do I ignite all the engines?" There are several methods of doing this, each of them quite satisfactory when used correctly.

### THE JETEX SYSTEM

The oldest method for igniting a cluster of model rocket engines is the Jetex system. Equal lengths of Jetex wick are inserted into the nozzles of the engines. The free ends of the wick are twisted together and a length of nichrome wire is wrapped around the wick to ignite it.

If the Jetex wick has been installed correctly, it will burn up the different strands and ignite the individual engines at about the same time. Before trying this system, though, it is important to understand all the precautions which must be taken.

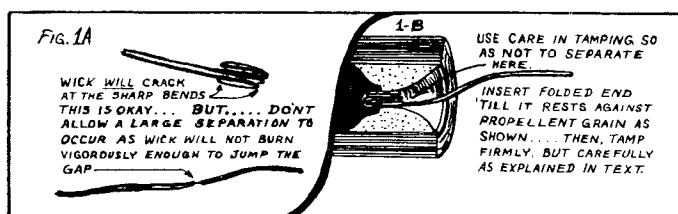

Three 2-1/3 inch lengths of Jetex wick are cut. One end of each piece of wick is folded 5 to 7 times as in the illustration. Be careful not to break any of the coating from the wire, or the wick will not burn evenly. These pieces of wick are inserted into the nozzles of the engines and pushed up into place against the propellant with the point of a pencil or a ball-point pen. It is very important to avoid breaking the wick and equally important to get the wick all the way into the nozzle and against the propellant grain. It is also important to get the wick tight enough in the nozzle so that it will not readily fall out.

With the Jetex in the engines and the engines in the rocket, the next step is to join the separate wicks together (see fig. 2). The distance from each nozzle to the point where the wicks are twisted together must be equal and must be as short as possible.

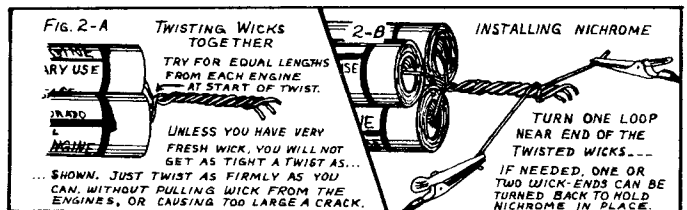

If all these preceding steps have been taken carefully and correctly, it is time to wrap a length of nichrome wire around the twisted portion of the wick, being careful the wire does not short-circuit against itself. Then put the rocket on the launcher, attach the microclips to the nichrome on opposite sides of the loop around the wick, give the countdown, and launch.

Ninety nine and 44/100ths percent of all cluster ignition failures are due to lack of care in installing the igniters. If the rocket veers off course during powered flight, chances are that one engine ignited earlier or later than another or failed to ignite at all. Since few people are 100% accurate all of the time, it is necessary to build cluster rockets with an extra large margin of stability to counteract the effects of imbalanced thrust.

Because of the difficulty in igniting all three engines at exactly the same instant, this system is not recommended for use with 1/2A or smaller engines, nor is it recommended for use with Series II engines. Rockets with the small Series I engines are more apt to go off course if there is any difference in their firing time, while the takeoff acceleration with Series II engines is apt to pull the wick out of the nozzle of any unignited engine, making ignition of all three engines a very rare occurrence.

The particular disadvantages of the Jetex system led to a search for other, more practical means. While no perfect systems have been developed nor appear likely to be developed, there are two other systems in use,

each with its own advantages and disadvantages which enable the rocketeer to use the system which best fits his needs.

## THE DIRECT ELECTRICAL SYSTEM

The direct electrical system is potentially the most reliable of all methods of cluster ignition. However, it also requires the most care of any system. If proper care is not exercised, it can be completely frustrating.

In this system the engines are prepared with standard nichrome igniters. The igniters are connected in parallel to the firing system so that when the launch switch is pressed current flows to all igniters at once.

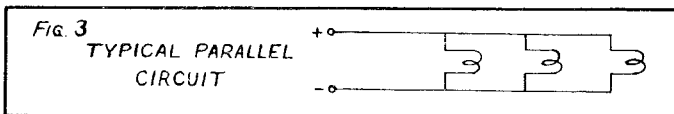

If everything has been done correctly, all three engines will fire at the same instant and the rocket will roar skyward. However, if there were any errors in the preparation of the rocket and the firing system, one or more of the rocket's engines will fail to ignite.

The first requirement with the direct system is that the nichrome igniters in the individual engines be installed correctly. There are several points to remember when installing nichrome igniters and many rocketeers fail to apply these points. It is first of all necessary to get the coil of the igniter against the propellant grain (9/16" from the rear end of the rocket engine). If this is not done there is little possibility of the engine igniting. If the engine is to ignite there must be no short circuits in the igniter.

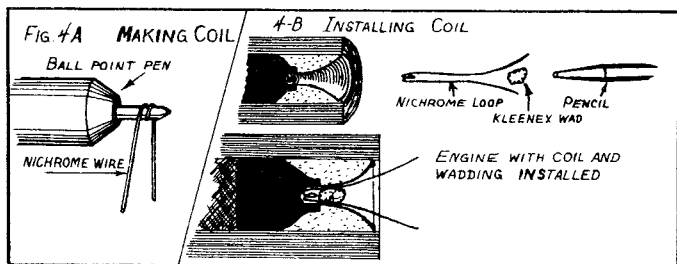

The loops of the coil must be spread far enough apart so there will be no possibility of one part touching another, even with the kleenex tamped in place. The parts of the nichrome leading to the coil must come out on opposite sides of the nozzle with the kleenex tamped in between them.

Even if the nichrome igniters are installed with the coil touching the propellant grain and no short circuits anywhere in the igniter, the battle is not quite won. After the engines are installed in the rocket it is necessary to connect the igniters in parallel to the firing system (See figures 3 and 5.) The microclips must be connected as far up into the nozzle as possible to give a minimum length of nichrome between them. Under no circumstances should the microclips be allowed to touch each other.

This writer has experienced the best success with this ignition system by fabricating a "whip" as illustrated and attaching the microclips to the igniters before placing the rocket on the launcher. The jaws of the clips are first cleaned carefully with sandpaper to assure a good electrical connection. The clips are then attached to the igniters, a clip from one whip to one end of the igniter, a clip from the other whip to the other end of the igniter. With the clips in place, pieces of masking tape are applied at all points where there is any possibility of the clips touching each other.

With this maze of wires in place, the rocket is gently placed on the launcher, and the leads from the firing system are attached to the remaining leads of the whips. The firing system used with this method of

ignition has to have plenty of electrical power. A 12 volt car battery in good condition will provide the necessary power provided that no more than 18 feet of #18 two conductor wire is used between the battery and the rocket and provided all connections, including those to the battery, are good. Flashlight cells will not provide enough current. (If all wiring, etc. is done carefully, 12 or more size D photoflash batteries in series will normally provide enough power to ignite the rocket.)

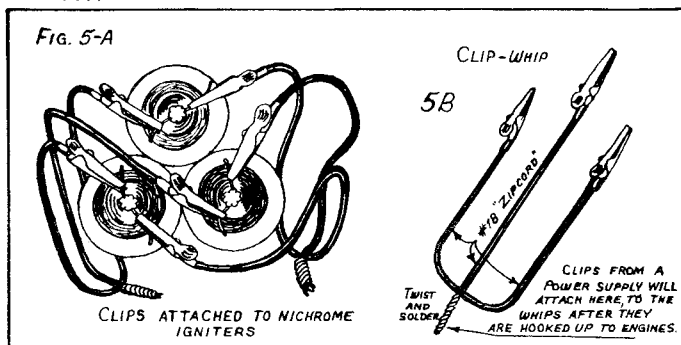

If all steps have been carried out correctly, the rocket can be launched. One of the main advantages of this system is that it can be used successfully with all types of engines, Series I and Series II.

## THE IGNITER MOTOR SYSTEM

The third system is reliable only when used with Series II engines. This method, known as the igniter motor system, uses a single 1/4A.8-0 engine in a special holder, secured to the launcher, to ignite the cluster of B3 engines in the same way that a lower stage ignites an upper stage.

The workings of this system can be seen in figure 6. The 1/4A engine is mounted in the center of a tube of the same diameter as the rocket's body. The tube with the igniter motor is taped to the launcher, and the rocket is lowered into position so that the rocket's body fits exactly over the top of the tube holding the igniter motor. The 1/4A engine is ignited electrically, fires for about .15 second, and then the forward wall of the propellant charge ruptures, hurling hot gases and particles up into the nozzles of the cluster, igniting the engines and sending the rocket skyward.

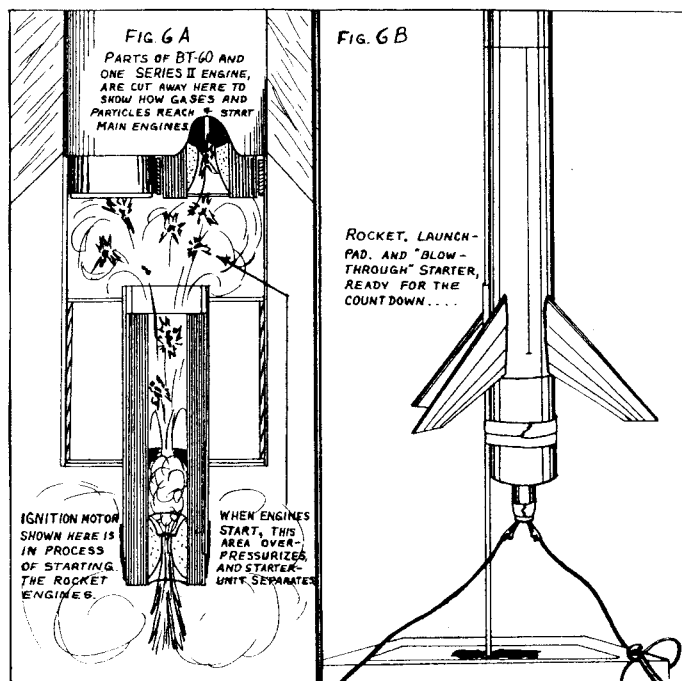

With this system it is necessary to allow an unobstructed path for the ignition gases from the igniter motor to the nozzles of the cluster. Only Series II

engines can be used in the rocket itself, since the nozzles of other engines are too small to give reliable ignition. It is also important to be sure that the igniter motor and its holder are securely fastened to the launcher.

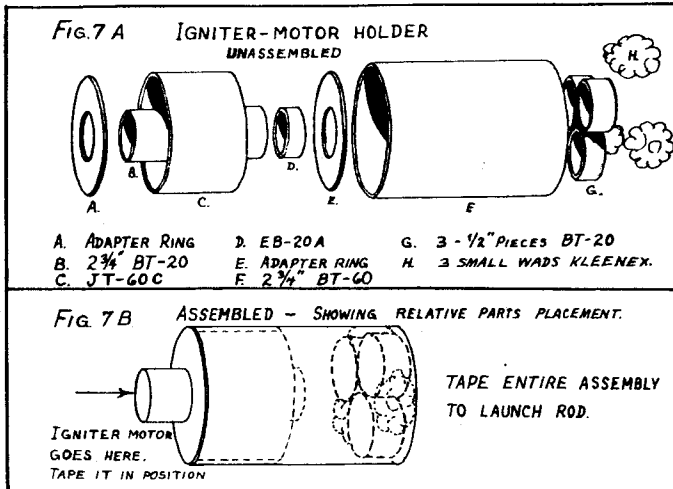

## TYPES OF ENGINES

Since there are so many different engines available to the modeler, the selection of the best one to use in his cluster rocket can become difficult. If maximum performance is desired from a single stage rocket and the Jetex ignition system is used, the proper engine type will generally be the B.8-4. If a 3 engine cluster rocket weighs under 4.5 ounces with engines in place, B.8-6 engines may be used.

To determine whether a particular set of engines is satisfactory for use in your rocket, use the Rocket Engine Selection Chart in the Estes catalog. Maximum thrust and total impulse for one engine are multiplied by the number of engines to provide the figures for the cluster. The same procedure should be followed with the maximum rocket weights.

The use of Series II engines gives certain advantages. The high takeoff acceleration stabilizes the rocket quickly, generally resulting in a straighter and higher flight than is obtained with Series I engines. Payload capability is also increased considerably.

## LAUNCHERS

Because of their greater weight and sometimes imbalanced thrust, cluster rockets put considerably more strain on the launcher than do smaller rockets. The standard Electro-Launch is recommended for rockets weighing up to 6 ounces using either the Jetex or the igniter motor systems for ignition. However if the base of the launcher is weighted down with a pair of bricks and the two-piece rod is soldered together, rockets weighing up to 9 ounces may be launched. If, in addition, a 48" length of 1/8" or larger piano wire or other steel rod is substituted for the two piece rod, rockets weighing up to 16 ounces may be launched safely.

Generally a rod longer and thicker than that needed for single engine rockets is preferable for launching cluster rockets. The thicker rod is less apt to bend or whip as the rocket ascends, and the longer rod will guide the rocket farther, giving the rocket higher speed and greater stability when it leaves the rod. Rockets launched from heavier and longer rods are less apt to veer off course due to imbalanced thrust and will weathercock less due to their greater airspeed when they leave the rod.

## ENGINE RETAINING

The method of holding the engines is important in any cluster rocket. Not only must the engines be held securely, but they must be aligned with the axis of the rocket so they work as a unit and exert all their thrust

in propelling the rocket rather than work against each other. In addition, the engine retaining system must seal the rear of the rocket so the ejection charge or upper stage ignition charge cannot leak out without doing its job.

There are two main systems for holding the engines. In the one, the functions of positioning, aligning, and sealing are built into the rocket. In the other, the engines are glued or taped together to align them.

In the first system body tubes just larger than the outside diameter of the engine (BT-20) are glued together and are glued inside the rocket's body (BT-60). These are positioned to handle the alignment of the engines. The spaces between the tubes are then filled with a fillet material such as tissue paper and glue, balsa putty, etc.

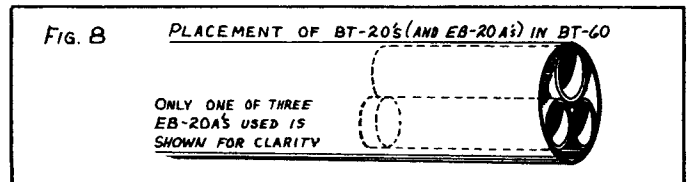

To keep the engines from moving forward during acceleration or backwards at ejection, they must make a tight friction fit in the holder tubes. This may be accomplished by wrapping the engine with tape until it takes considerable effort to push it into position. The other alternative is to use wire engine holders as shown in fig. 9. These make the replacement of engines considerably easier. They must, however, be positioned carefully so they do not interfere with the fins.

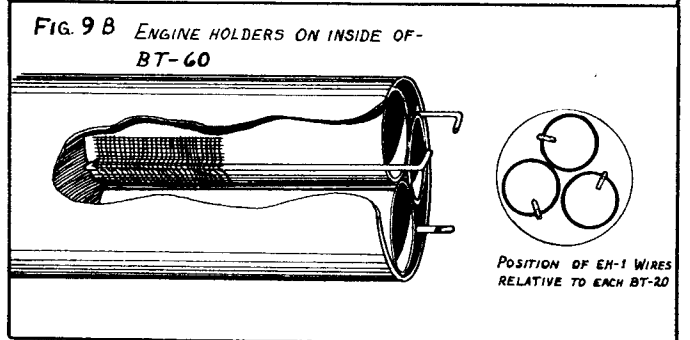
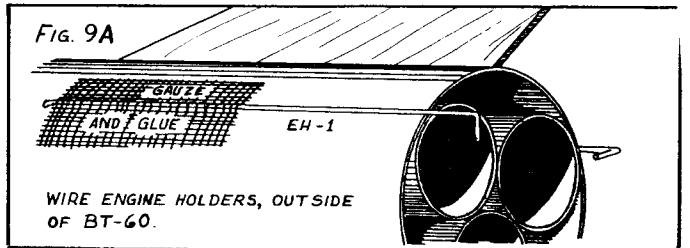

In the second system the engines are first glued or taped together, and then inserted into the rocket body. It is usually easier to obtain and maintain correct alignment by gluing the engines together than by taping them together. Enough tape is then wrapped around the outside of this group of engines to give a very tight

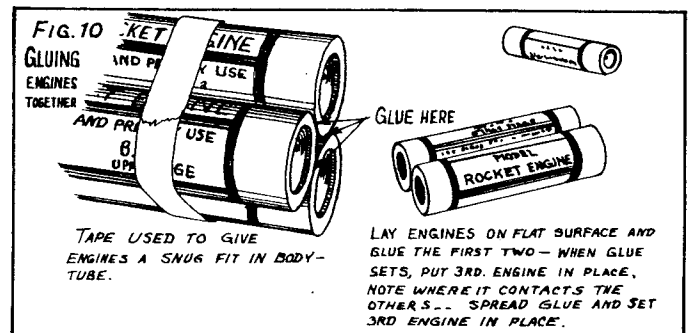

friction fit inside the rocket body. Finally, facial tissue or similar paper is tamped tightly into all holes around and between the engines to seal the rear of the rocket and control the ejection gases. (See fig. 11.)

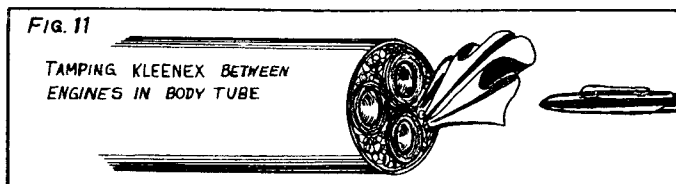

Some experiments with mounting engines in cluster rockets at an angle to create spin have been tried. However, it appears that spin fins are more effective and more reliable.

## RECOVERY SYSTEM

Since the cluster rocket is larger and heavier than the conventional model rocket, its recovery system must be designed to withstand greater stresses than those normally encountered in a model rocket. The recovery system in a cluster rocket almost always uses at least one parachute; other devices have not yet proven practical. Generally two parachutes are used on rockets with large payload sections, one parachute on rockets with no payload section or just a small one.

On rockets with large payload sections two parachutes give more reliable recovery, since there is no possibility of the heavy payload section breaking the shock cord at ejection and no possibility of its snapping back and tangling in the parachute of the lower section if it is completely separate. Cluster rockets without payload sections are best recovered with a single parachute. The nose cone alone is too small to require a separate parachute, and will not put the strain on a shock cord that a 4 oz. payload section would.

Parachutes are normally attached directly to a screw eye in the base of a payload section with no shock cord between the parachute and the payload section. To reduce the possibility of fin breakage on landing the shock cord on the lower or propulsion section of the rocket is often attached to the outside of the body of the rocket near the engines. This is done by gluing one end of a string in a hole in the body about 1" from the rear end and tying the other end of the string to reach up the body and into the front end of the tube (see fig. 12).

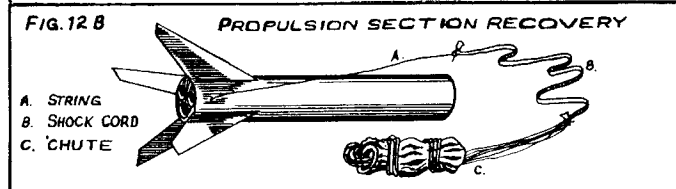
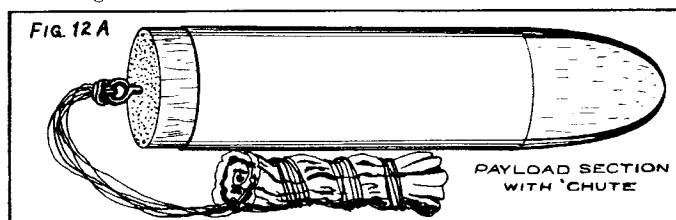

The best way to protect parachutes from the heat of the ejection charge is to use wadding and plenty of it. The wadding should be flameproofed. Flameproof cotton or flameproof tissue paper will work, but rock wool,

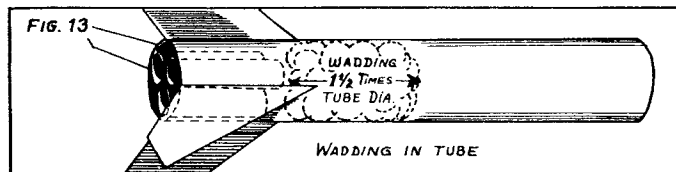

available from most lumber yards, gives the best results. Pack enough wadding into the rocket to fill it for a distance equal to at least 1-1/2 times the diameter of the body. The wadding should be fairly tight against the sides of the tube to give an effective seal.

The size of the parachutes should be in keeping with the weight of the rocket. Parachutes larger than 18" will rarely be needed. Normally a 16" to 18" parachute on the lower section of the rocket and 12" to 16" parachute on the payload section will be sufficient.

## STABILITY

The fins of a cluster rocket are one of the most critical areas in its construction. They must be large enough to keep the rocket stable even if the engines fire at different times and even if one or more engines fail to ignite. The fins must also be strong enough to hold up to all aerodynamic stresses against them and to withstand landings against rocks and pavement.

The best fin material for cluster rockets is 1/8" thick balsa sheeting (BFS-40). The fins must be cut out so the grain of the balsa follows the leading edge of the fin. The edge of the fin that is to be glued to the body must be straight to give a strong enough glue joint. This requirement is best filled by wrapping a sheet of sandpaper around the body and passing the fin forward and back on the sandpaper several times.

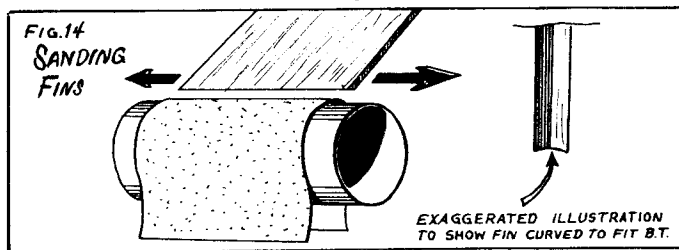

When the fin positions have been marked on the body tube and the fins sanded, they can be glued in place. For best results, apply only a very thin line of glue along the inside edge of the fin. Press the fin into position against the body, and hold it in place for a couple of minutes. Then repeat this procedure with the other fins. After the glue has dried, reinforce each joint by applying a fillet of glue in the corner between fin and body as in fig. 15. The rocket should be balanced on its side (but no pressure should be put on the fins themselves) while the glue dries so it will not flow out of position.

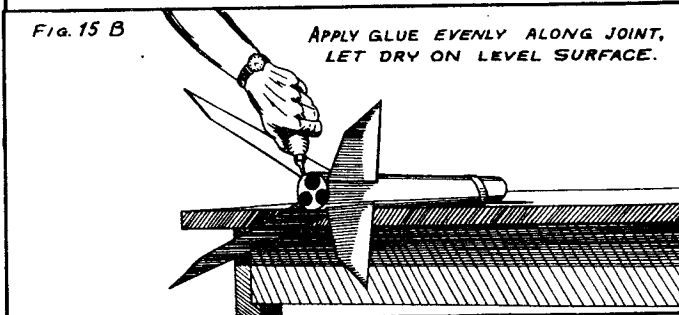
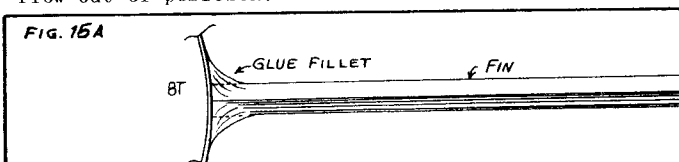

Stability in a model rocket depends on many things, including location of center of gravity, body diameter, nose cone shape, positioning of fins, shape of fins, and surface smoothness. To obtain proper stability in a cluster rocket it is best to make the fins larger than would appear necessary. The center of pressure of a cluster rocket must be at least 1/2 the body diameter behind the rocket's center of gravity (see Technical Report TR-1). If the rocket's stability is tested by the string method described in TR-1, it is best to have at least a 20° margin of stability.