

Centuri SKY-TRAK

ASSEMBLY INSTRUCTIONS

FOR BEST RESULTS . . . FOLLOW DIRECTIONS CAREFULLY!

INTRODUCTION

The Sky-Trak is an optical tracker or theodolite capable of obtaining precise altitude data for model rockets. As with any theodolite, however, its uses extend beyond the realm of model rocketry — it may be useful in teaching the basics of trigonometry or surveying.

The Sky-Trak is a precision instrument and, while largely pre-assembled at the factory, should be constructed with

great care to insure optimum performance. Read the instructions completely before beginning the assembly, and be sure all parts are included. Note that the various screws, hexnuts, and washers needed for the head, azimuth base, and tripod leg assembly are contained in individually marked plastic pouches — to avoid losing these parts, open the pouches only when the instructions call for specific parts. Careful assembly of the Sky-Trak will insure you a precision instrument that should give many years of service.

TO ASSEMBLE THE SKY-TRAK,
YOU WILL NEED THE FOLLOWING:

X-ACTO
KNIFE



CENTURI
SUPERBOND
GLUE



RUBBER
BANDS



SCREWDRIVER



PARTS LIST

- 1 SIGHTING TUBE
- 1 CROSS HAIR STRING
- 2 HTC-175
- 1 ALIGNMENT GUIDE
- 4 CARDPAPER MOUNTS
- 1 LAUNCH LUG

- 1 PROTRACTOR (EL.) BASE
- 1 ELEVATION PROTRACTOR
- 1 SUPPORT ARM & BASE ASSEMBLY
- 1 ELEVATION POINTER
- 1 AZIMUTH POINTER
- 2 # 6 SHEET METAL SCREWS
- 2 CAP NUTS
- 1 THREADED STUD
- 5 WASHERS

- 1 AZIMUTH BASE
- 1 TRIPOD BASE
- 3 1½" 10-24 FLATHEAD SCREWS
- 3 10-24 HEXNUTS
- 3 10-24 WINGNUTS
- 3 LEVELING SPRINGS
- 1 ½" 8-32 SCREW
- 1 8-32 WING NUT
- 1 AZIMUTH PROTRACTOR

- 3 LEGS
- 6 WASHERS
- 3 3½" 10-24 ROUNDHEAD SCREWS
- 3 10-24 WINGNUTS
- 3 S-HOOKS
- 1 STAR CHAIN



SIGHTING TUBE

- 1 Cut the cross-hair string into two 3" lengths.
- 2 Cut out the alignment guide, position it on one of the HTC-175's, and mark the proper spacing for the cross hairs.
- 3 Glue the cross hairs in place and secure with one or two rubber bands to keep the hairs taut while the glue sets.
- 4 Smear glue into the end of the tube farthest from the unpainted area. Carefully insert the cross-hair unit into the tube, with the cross-hairs recessed into the tube.
- 5 Glue the four cardpaper mounts onto the launch lug at 90° intervals.
- 6 When the glue has dried, glue the peep-sight into the one end of the other HTC-175.
- 7 Smear glue about 3" from the other end of the sighting tube. Position the peep-sight unit so that the cardpaper mounts form a 45° angle with the cross-hairs. Then carefully insert the unit into the tube a distance of 3". Be sure the peep-sight is recessed into the tube, as shown in the drawing.

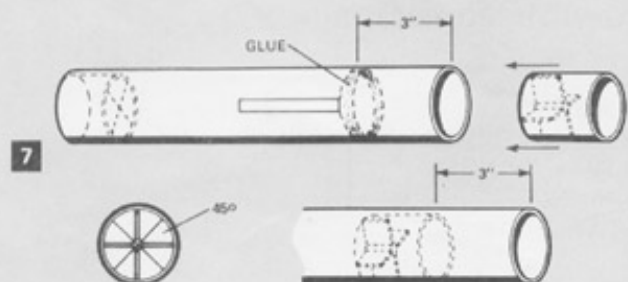
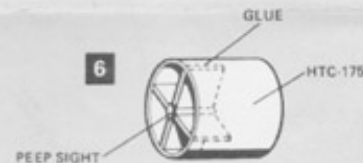
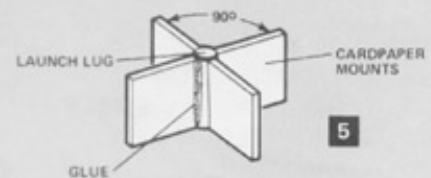
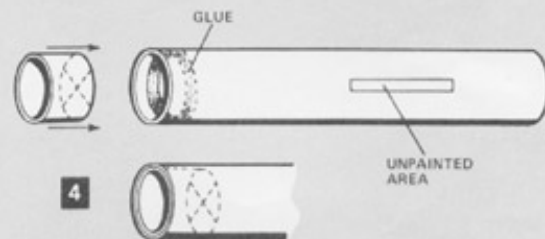
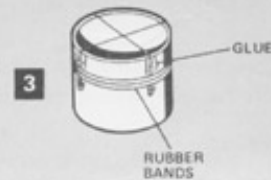
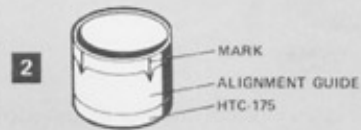
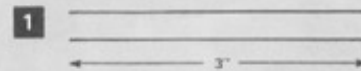

COMPLETING THE HEAD UNIT

- 8** Glue the elevation protractor base onto the unpainted area of the tube. The center hole of the protractor base should be 11" from the far end of the tube. As viewed from the rear, be sure the protractor mounting holes are on the left side.

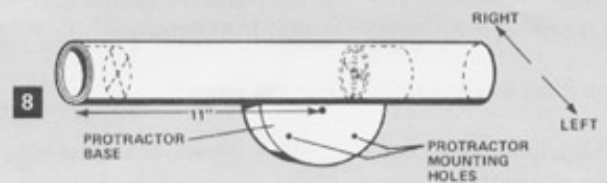

- 9** Attach the elevation protractor with the two # 6 sheet metal screws. Be sure the top edge of the protractor is level with the edge of the sighting tube.

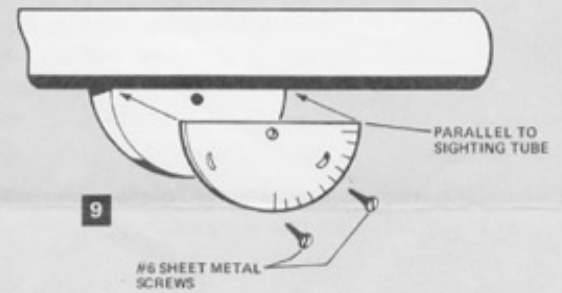

- 9 A.** Cement $4\frac{1}{2}$ " disc to the azimuth disc, and center pointer on the azimuth disc. Apply airplane cement to orbit level and center it over pointer with flat side to yoke assembly.

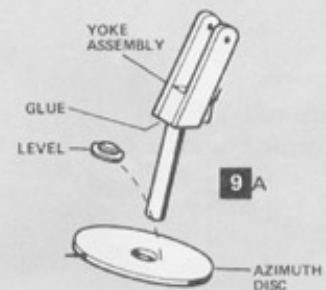

- 10** Attach the sighting tube unit to the support arms with the washers, cap nut, and threaded studs. Two of the washers are mounted to the left of the protractor, and three on the opposite side of the protractor base.

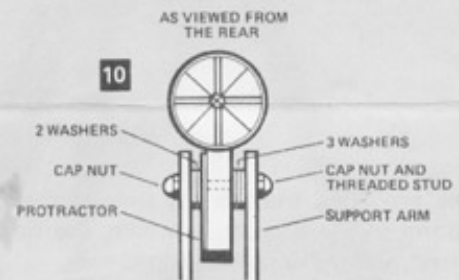

- 11** Glue the elevation pointer securely into the left support arm. Glue the azimuth pointer to the support arm base.

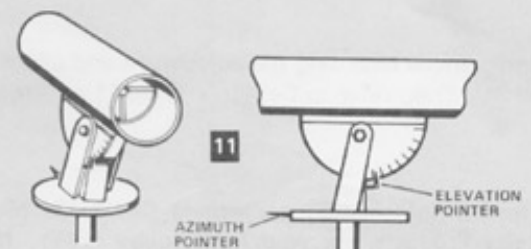

AZIMUTH BASE ASSEMBLY

- 12** A. Insert the three 1/2" 10-24 flathead screws through the azimuth base and secure tightly with the hexnuts.
- B. Slip the three leveling springs over the screws.
- C. Slip the tripod base over the 10-24 screws and secure with the wingnuts.

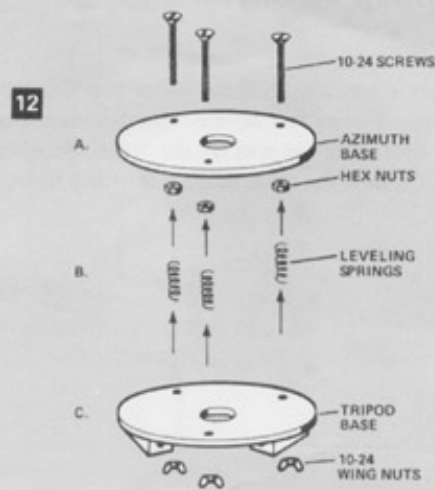

- 13** Attach the azimuth protractor to the azimuth base with the 1/2" 8-32 screw and wingnut.

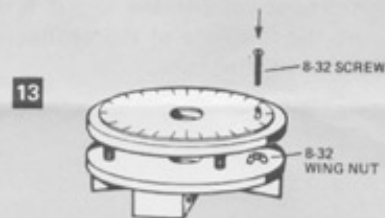

LEG ASSEMBLY

- 14** Attach the legs to the tripod base with the 3/2" 10-24 bolts, wing nuts, and washers.



- 15** Attach the star chain to the legs with the S-hooks.

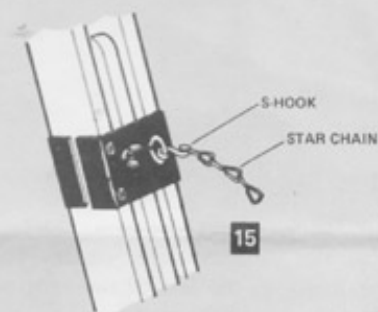

- 16** Apply the pro-stripe trim to the ends of the sighting tube, the rim of the support arm base, the rim of the azimuth base, and the rim of the tripod base.

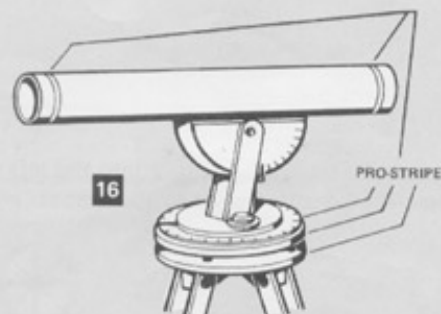

- 17** For instructions regarding the adjustment and operation of the Sky-Trak, refer to Centuri's TIR-101 on Altitude tracking.

For further information concerning CENTURI Model Rocketry Products, see your local hobby dealer. If he cannot help you, write direct to CENTURI ENGINEERING CO., P.O. Box 1988, Phoenix, Arizona 85001.