

MODEL ROCKET NEWS

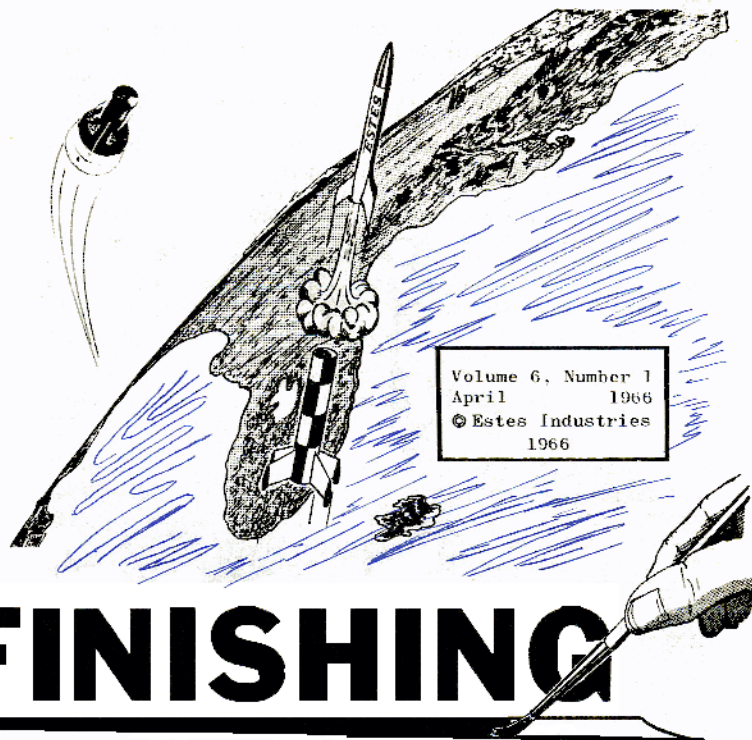

MODEL FINISHING

When you finish a model, does it have streaks and bubbles in the paint? Do the fins have deep grain marks in them? Do you hesitate to show it to experienced modelers? A good model rocket doesn't look like it's made of paper and balsa--it looks like a perfect miniature of the real thing, as though it were made of a solid piece of mirror-smooth metal or plastic. There's nothing secret about good appearance: It's the result of extra care and the right materials.

PREPARING THE SURFACE

The finish of a rocket starts with the very first steps of assembly. Sloppy gluing and other messy habits will ruin the appearance of a rocket so that nothing can be done to get the perfect appearance which is desired. On the other hand, careful construction will make a model look good even before the paint is applied.

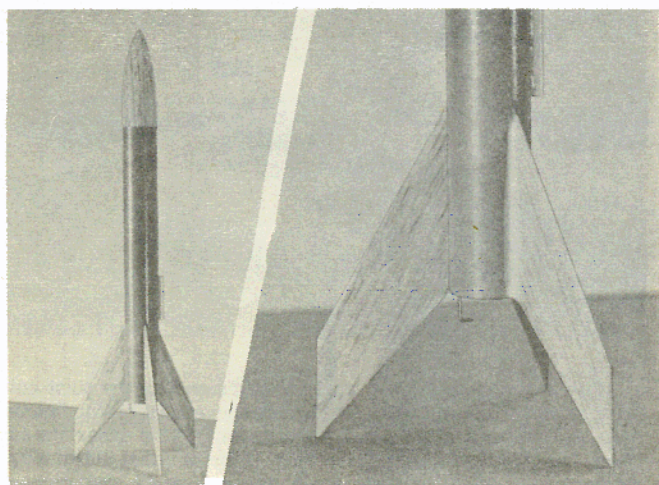

Before anything is glued to it, the body tube should be sanded lightly with 320 grit or finer sandpaper (SP-320). After sanding, all dust is removed with a soft cloth. The fins should be sanded to shape and smoothed out with SP-320 also. Since it is easier to sand the fins before they are glued in place, as much sanding as possible should be done now. Do not apply sanding sealer or paint yet, however, as either material will fill the pores in the wood enough to keep the glue from penetrating and making a good joint.

The nose cone can generally be finished separately from the rest of the model. When working on it, hold it in a scrap piece of body tube. Sand it smooth, then follow with the normal sealing and painting procedure as described later in this article.

USING SEALER

After all parts have been glued in place, apply a coat of sanding sealer to the balsa. Avoid getting sealer on white glue or the body tube. (If the model is built with BT-30 or BT-40 the tube may be sealed; other types of tubes should be kept clean.) Set the model aside and let it dry thoroughly. Four hours is often the best drying time. When the humidity is high it's better to allow a full day.

When the sanding sealer is completely dry, sand thoroughly with very fine sandpaper (SP-320). Blow or wipe the dust off the surface, then apply a second coat of sealer and let it dry. Continue applying sealer and sanding until all the grain in the balsa is filled. This requires patience and a minimum of three coats. The actual number of coats of sanding sealer necessary varies from one sheet of balsa to the next and also depends on how thoroughly the surface is sanded. Practically all of the sealer should be sanded off after each coat--the purpose of this procedure is to fill the grain, not the smooth areas of the sheet.

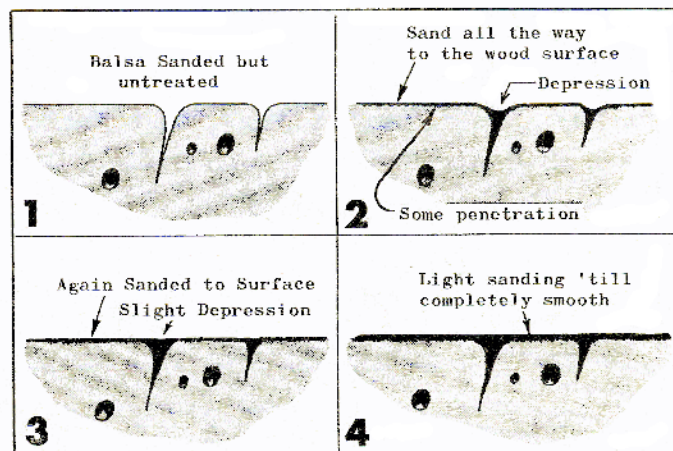

Most rocketeers use the same system on the nose cone. Others, however, will finish the cone separately from the rest of the rocket and apply the sealer by dipping it into the liquid.

A large container with a wide mouth is necessary for this purpose. The standard Astroseal jar will work with most small nose cones as long as the jar is neither too full nor too empty. The cone is dipped into the sealer up to its shoulder and held in place for a few minutes to let the fluid soak in. It is then pulled up and held over the jar while the excess sealer drips back into the bottle. After the cone has quit dripping it is hung up to dry with the tip down. Generally two to four coats of Astroseal will be sufficient if the cone is sanded thoroughly between coats.



Apply the Base Color

Once you are satisfied that the surfaces of the model are perfectly smooth and that all the grain has been filled, it's time to apply the base color. If the model is going to be painted all one, non-fluorescent color, the base coats will be the final coats. When the rocket is to be painted a fluorescent color, the base coats should be white. In all other cases, the base color should be the lightest of the final colors. For example, when a rocket is to be finished with red, black and yellow, the yellow should be applied first.

Apply a light, even coat of the base color and set the model aside to dry. It is important to apply only a light coat--if too much paint is put on the rocket at once, it will run. Since a run in the paint is virtually impossible to hide or correct, it is wise to use many thin coats rather than a few thick coats. When the first coat has dried, apply a second--keeping it light and thin. Continue until enough coats have been applied to give a clean, pure color. Finally, set the model aside in a dry, warm (but not hot), dust-free area for at least a day to let the paint dry completely. The longer the paint cures, the fewer problems will be apt to arise when further colors are applied.

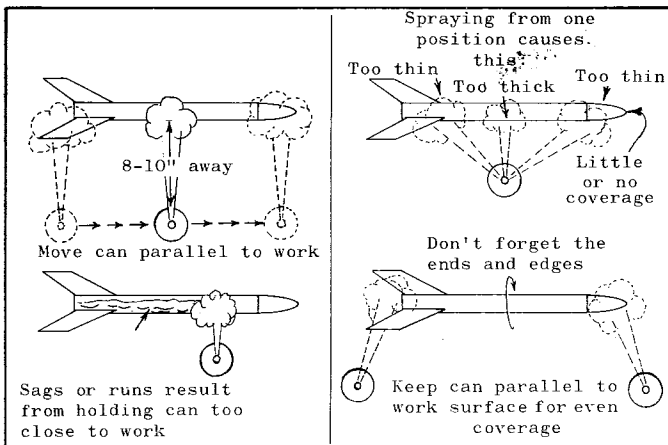

Butyrate dope does not adhere well to the surface of commercial spiral-wound body tubes. When masking tape is stuck to the paint and then removed it sometimes peels the paint off. As long as masking tape is not going to be used in finishing the rocket, it is safe to use butyrate dope. If tape will be used during the finishing process, butyrate dope should be used only on BT-30 or BT-40 bodies. In view of this, enamel paint is normally the best material to use for base coats on the body.

Make a rocket holder by gluing an empty engine casing in one end of a piece of BT-20, 30 or 40. The casing should project about 2" from the tube. Wrap the casing with tape to fit tightly into the engine section of the model. By using this holder it's possible to apply paint to the model without also applying fingerprints (and, incidentally, without applying paint to your hand.) A drying support can be made by gluing an engine casing to a 4" square piece of cardboard.

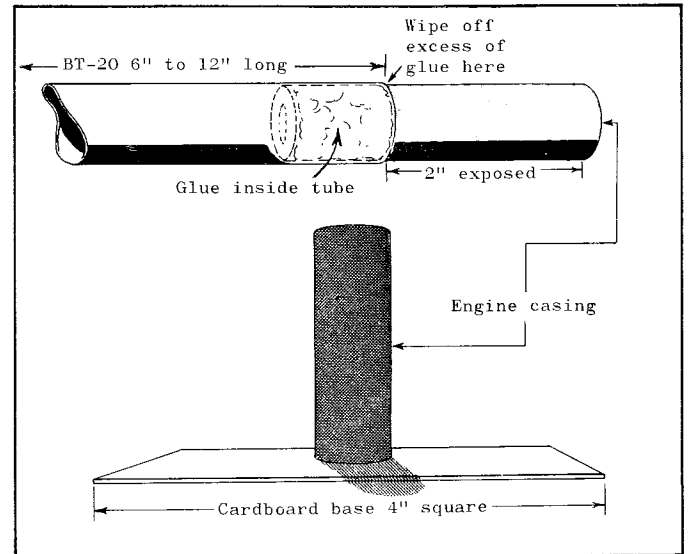

Add the Second Color

When the base color has cured completely, cover all the areas on the model which are to remain this color. Small areas should be covered by applying masking tape directly to the surface. Large areas (the whole front half of the model, for example) should be covered with ordinary typing paper and the edges sealed with masking tape as shown. It is important to seal the tape down tightly along the edge. If you have a steady hand, it's possible to apply the second color by brush without masking. However, unless you're very sure of your abilities, it's best to go ahead and mask.

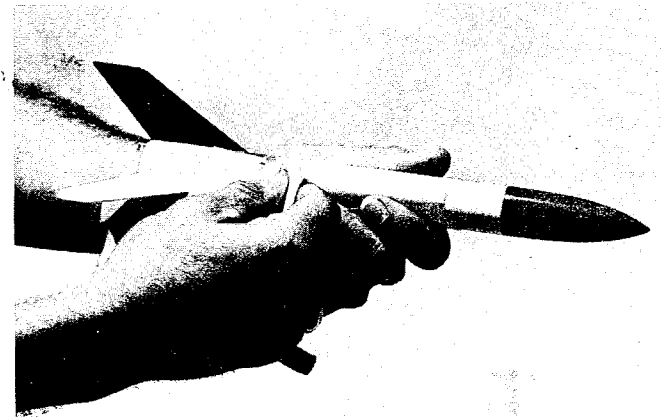

With the model masked, apply another coat of the first color. This is done to seal completely along the edges of the masking tape and prevent the second color from leaking under the tape. Occasionally a second or third coat of the original color may be necessary to get a complete seal. When in doubt, put more on, since any leakage will look lousy. Let the seal coat dry until it is no longer sticky, then apply a coat of the second color. Apply additional coats of this color at the same rate as with the first color--remembering to keep the coats thin and even and remembering to let each dry properly before putting more on. Try to use just enough paint to get a clean color. Too thick a layer of paint can cause troubles when removing the masking.

After the last coat of the second color is in place and has dried so it can be handled safely, remove the masking. There

Enter Now! ESTES SCIENCE FAIR!

Did you use model rocketry in a science fair project this year? If so, we've got a special contest for you. To enter, just send photos of your exhibit, a general description of the project and a copy of your report to: Science Fair Contest, Box 227, Penrose, Colorado, 81240. If your project is picked as one of the best by the judges, you can win one of these great prizes.

- 1st Prize--\$50 in merchandise credit.
- 2nd Prize--\$25 in merchandise credit.
- 3rd Prize--\$10 in merchandise credit.
- 4th Prize--\$5 in merchandise credit.

— CONTEST RULES —

- 1) Each entry must include a photo of the exhibit as used in the actual science fair, a general description of the nature and extent of the project, a copy of the report used in the project and a statement signed by your teacher or parent certifying that the entry depicts the project as it actually was entered in the fair.
- 2) Entries must be postmarked no later than July 31, 1966.
- 3) Employees of Estes Industries and members of their immediate families are not eligible to enter this contest.
- 4) The decision of the judges is final.
- 5) All entries become the property of Estes Industries, Inc. No material will be returned.

NOTE: Prizes previously won by the project will not be considered in judging entries. However, the Editor would appreciate it if you would include such information.

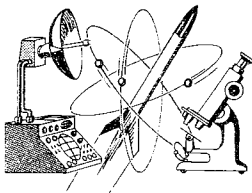

MODEL ROCKET NEWS

The Model Rocket News is published by Estes Industries, Inc. Penrose, Colorado. It is distributed free of charge to all the company's mail order customers from whom a substantial order has been received within a period of one year. The Model Rocket News is distributed for the purpose of advertising and promoting a safe form of youth rocketry and for informing customers of new products and services available from Estes Industries. Rocketeers can contribute in several ways towards the publication of the Model Rocket News:

- (1) Write to Estes Industries concerning things you and your club are doing in this field which might be of interest to others.
- (2) Continue to support the company's development program by purchasing rocket supplies from Estes Industries, as it is only through this support that free services such as the Model Rocket News, rocket plans, etc., can be made available. This support also enables the company to develop new rocket kits, engines, etc.
- (3) Write to the company about their products and tell what you like, what you don't like, new ideas, suggestions, etc. Every letter will be read carefully, and every effort will be made to give a prompt, personal reply.

Vernon Estes
Publisher

William Simon
Editor

New Products

ARCAS[®]



Recommended
Engines
B. 8-4, A. 8-3
1/2A. 8-2

*Reg. trademark of Atlantic Research Corporation, Alexandria, Virginia.

High performance scale operating model of the famous Atlantic Research Company sounding rocket. Easily assembled, this model looks good on the shelf, on the launch pad and in the air. Upon ignition, the ARCAS zooms hundreds of feet into the sky; returns gently by its 18" multi-color parachute ready for a fresh engine and another flight. Kit comes complete with all parts, decal and instructions (but no engines). Shipping weight 14 ounces.

SPECIFICATIONS

Length	22.82"	Body Dia.	1.325"
Fin Span	3.82"	Weight	1.44 oz.

CAT. NO. 651-K-26

ONLY \$2.00

HONEST JOHN

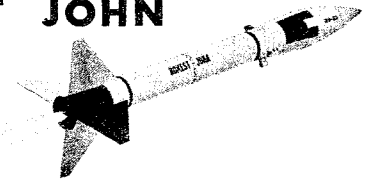

Recommended
Engines
B. 8-4, A. 8-3
1/2A. 8-2

High performance flying scale model of the U.S. Army surface-to-surface missile. The Honest John features parachute recovery, exact detailing, a complete set of decals and many other items to make this one of the most exciting models you'll ever build. Recommended for experienced modelers, this kit comes complete (but no engines). See this issue's wrapper for specifications. Shipping weight 14 ounces.

Cat. No. 651-K-27

Only \$2.00 each

NOT-SO-NEW... but one of our best!

Astron ALPHA



SPECIFICATIONS
Length 12.25"
Fin Span 2.1"
(from center)
Body Dia. 0.976"
Weight 0.75 oz.

The easiest parachute model to prep and fly ever designed, the Astron Alpha goes together quickly, features positive quick-change engine mounting and a 12" chute for reliable recovery. With its low weight and streamlined design, the Alpha will reach high altitudes consistently. This kit comes complete except for engines. Recommended engine types are the 1/2A. 8-2, A. 8-3, B. 8-4, 1/4A. 8-2 and B 3-5. Shipping weight 6 ounces.

Cat. No. 651-K-25

Only \$1.50

RA-2055 Rings

Perfect for building models with the new BT-55 body tube. Centers a BT-20 inside the larger tube for engine mounts, transitions, etc. Set includes 10 light-weight, high strength card stock rings. Shipping weight 2 oz.

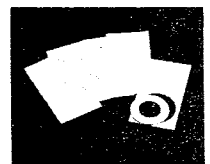

Cat. No. 651-RA-2055

\$.30 Per Set

The Idea Box

Multiple Igniter Connector

A practical method for wiring the igniters on cluster birds comes from Charles H. Muncy of Iaeger, W. Va.

Obtain an 8 to 10" piece of #24 thru #28 gauge copper wire and bend a pair of rings as shown. Wrap the inboard igniter leads around the inner ring first. Position the outer ring and wrap the remaining leads around it as shown.

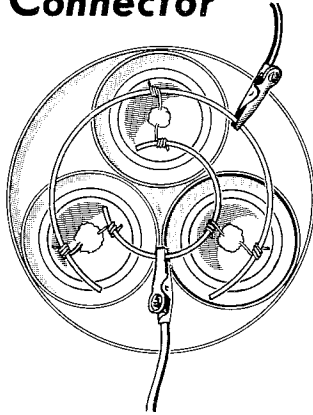

Interlock Key does Double Duty

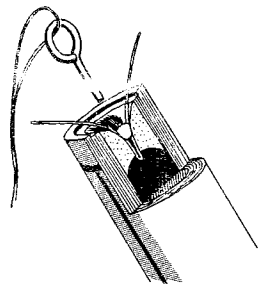

Use your Electro-Launch safety interlock key to tamp the wadding into the engine nozzle when installing igniters suggests Mike Foley of Las Vegas, Nev.

Threading the Swivel Eye Made Easier

Patrick Mondoy of Molokai, Hawaii suggests a neat and easy way of attaching the shroud lines to the snap swivel.

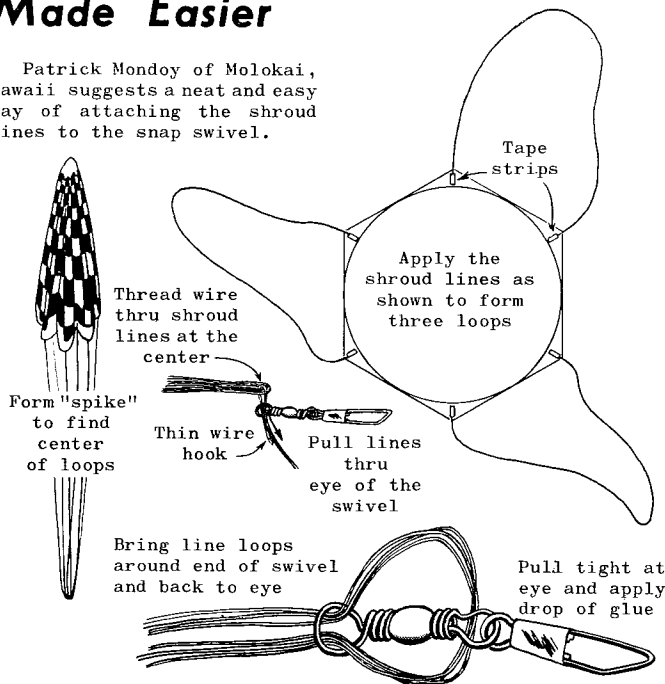

Scale Display Nozzle Removable for Flight

Some rockets, especially scale models, have better appearance if a scale engine nozzle is used.

Jeff Phillips of Royal Oak, Michigan suggests this disc-coupler set-up upon which to build the scale detailing yet have it easily removable for flying.

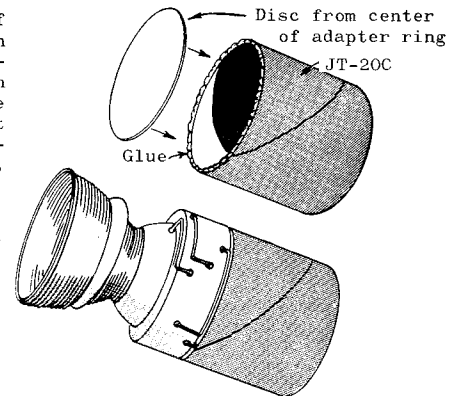

Straw for Long Reach Dispenser

To apply glue in hard-to-reach places, try this technique suggested by Roger Longhorn, New Hampton, Iowa. Most any fair sized straw or launching lug will work.

Squirt glue into straw

Finger on end of straw controls flow of glue

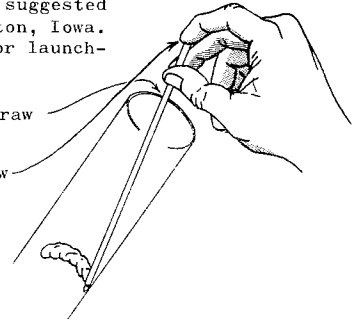

Engine Puller made from Dime Store Scissors

Rick Rjetland of Watertown, South Dakota suggests this modification of low cost paper scissors for pulling tightly fitted engines from rockets.

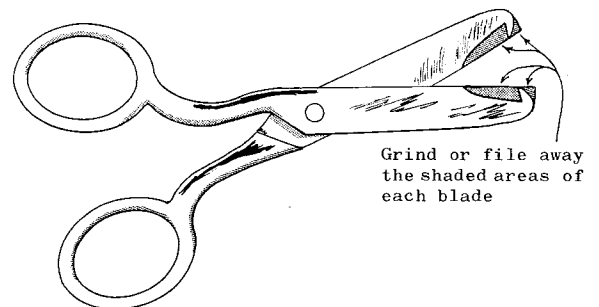

EH-2 Great for Big Birds Too!

Slot for engine holder movement

Both the EH-2 & EH-3 make spent engine removal an easy job in larger rocket models using BT-55 or BT-60 tubes.

A standard engine mount kit is adapted as shown.

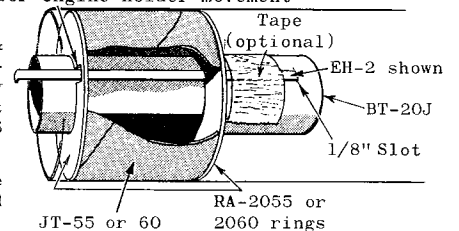

Altitude Calculations made Simple!

There are many ways of determining the altitude reached by a model rocket, some simple, some more complex. All require certain basic information--specifically angle and baseline distance. The systems described in Technical Report TR-3 are the most accurate of their type. However, the same information (angle and baseline distance) can be used with other calculation methods based on simple geometry.

Regardless of the calculation method to be used, it is necessary to measure the distance from the launcher to the tracking station (the baseline). This distance should be approximately equal to the height the rocket is expected to reach. If the rocket is expected to go between 400 and 600 feet, the tracking station should be 500 feet from the launcher.

The simplest type of tracking device consists of a protractor and a sighting stick. A more versatile and easier to use device is the Altiscope, available from most dealers or by mail from Estes Industries. At the tracking station the tracking device is set so that it reads 0° when aimed at the rocket on the launcher and 90° when aimed straight up. If the tracker is not "zeroed in" on the launcher it will give incorrect information.

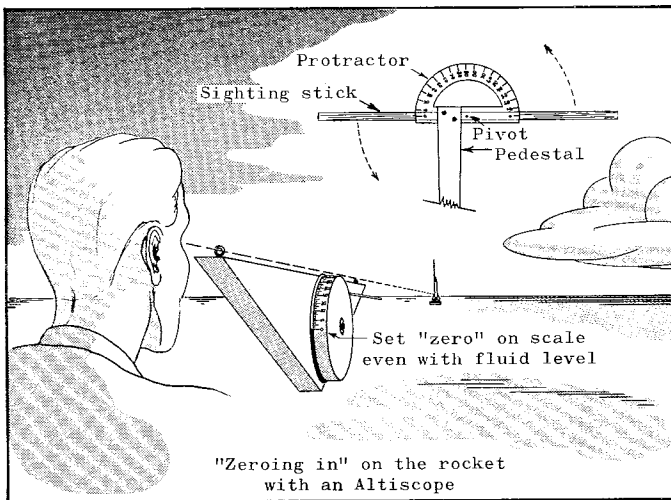

When the operator at the tracking station is ready, the rocket is launched. He follows the rocket with his Altiscope as it rises and when it reaches its peak altitude he stops or locks the Altiscope. The indicated angle is then read from the protractor scale.

With single-station tracking it is necessary to assume that the rocket went straight up. If it didn't, there's nothing that can be done with the information on hand to get an accurate height. With this limitation in mind, we can go on to apply one of the three following calculation methods.

I. GRAPH PAPER

One of the basic principles of geometry is that when the corresponding angles in two triangles are the same, the lengths of matching sides will be proportional. Triangles with identical angles are called "similar triangles." If the sides of one triangle measure 5, 6 and 7 inches respectively, a similar triangle with the first side 10 inches long will have the other two sides 12 and 14 inches long. In effect, the one triangle is a scale model of the other.

In altitude tracking we form a triangle with the launcher, the rocket and the tracking station at the corners. When we assume that the rocket goes straight up we are assigning an angle of 90° to the launcher corner. The second angle, located at the tracking station, is measured by the tracker. The third angle does not need to be measured, since it depends entirely on the first two angles.

To apply this principle to altitude determination, you will need a sheet of 1. 10" grid graph paper. Let the lower left hand

corner of the ruled area represent the launcher position. Using a scale of 1" = 100', measure the scale distance for the baseline along the bottom edge of the ruling and mark the location of the tracker. (If the tracking station is 500 feet from the launcher, the paper is marked 5" from the corner.)

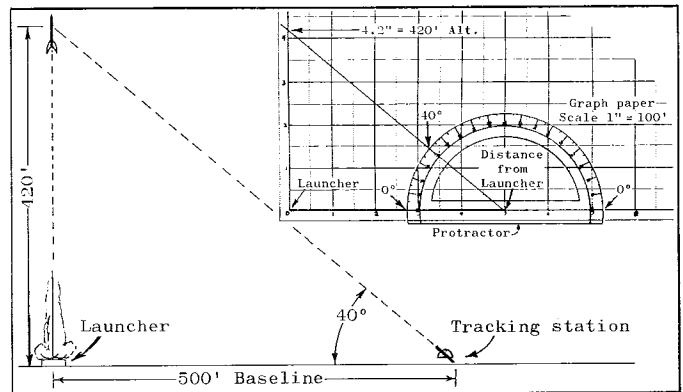

Place a protractor on the sheet so its center point is on the mark and the 0° lines are on the edge line as shown. Now mark the paper at the angle which the tracking station provided (for example, 40°). Draw a straight line from the tracking station mark, through the angle mark to the vertical edge of the ruled area. The diagonal line meets the vertical edge line at the point which represents the position of the rocket. You should now have a triangle with two sides formed by the edges of the ruled area and the third side a diagonal line drawn at the angle given by the tracker. This triangle is a scale model of the triangle formed by the launcher, rocket and tracking station.

Finally, measure the distance from the launcher corner to the rocket corner (where the diagonal line crosses the vertical line). With a baseline of 5" and an angle of 40°, the diagonal line will cross the vertical edge line 4.2" from the corner. Since 1" = 100 feet, the rocket reached 420 feet. If the baseline is 600 feet and the angle is 38°, the tracking station mark will be 6" from the corner and the diagonal line will cross the vertical edge line 4.7" from the corner. In this case the altitude is 470 feet. Check these two examples by plotting them on a sheet of graph paper, then try some baselines and angles of your own.

II. THE 2-D COMPUTER

The same principle of similar triangles is used with the 2-D computer. This is a commercial device (Cat. No. AC-1, \$.25) that gives almost instant altitude readings. Instead of drawing triangles on the paper, the computer has an arm on its protractor that forms the diagonal line. Altitude and baseline distances are marked on the chart. When the protractor is positioned on the tracking station point and set to the proper angle, the altitude can be read directly without measuring. Since complete instructions are included in the kit, it isn't necessary to go further into operating methods in this article.

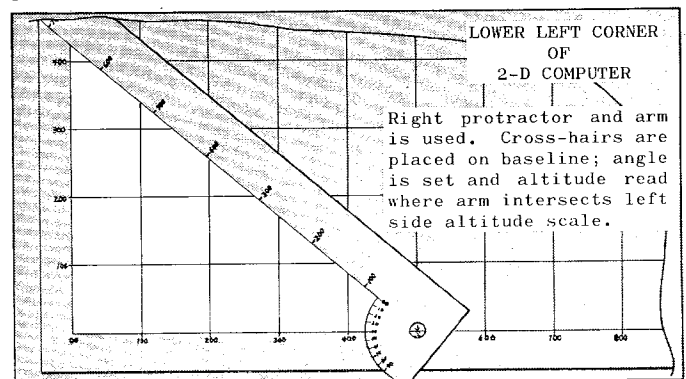

III. THE NOMOGRAM

The altitude nomogram is probably the easiest device to use in computing the height reached by a model rocket. In operation a straight line is drawn from the baseline distance, through the angle to the altitude column. Where the line crosses the altitude column, the height of the rocket is read. For example, when

NOTES FROM THE BOSS

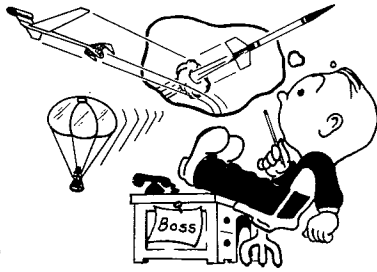

Back in 1961 the Air Force came out with a directive expressing approval and support for model rocket activities. Now NASA's done the same. The following statement by the late Dr. Hugh L. Dryden outlines the attitude of the NASA administration towards modeling activities:

AEROSPACE MODELING

If America is to maintain a pre-eminent position in the aerospace age, it is important that the nation's youth be well grounded in the fundamentals of aeronautics and astronautics, both as future supporters of aerospace activities and as participants in the art. Model building is an effective means of teaching many of the fundamentals of the science of aeronautics and astronautics and is an important factor in motivating many persons to careers in science and technology.

It was first proved by experience gained during World War II that the skills developed by model builders during elementary and high school years are a major influence in encouraging interest in aerospace oriented careers. The basic know-how gained in these early years lays a foundation of technical inclination that leads naturally to scientific pursuits.

In order to participate in model activities, one must both build and fly model craft. This involves many related elements, such as: skill in construction and adjustment of operating components and systems; application of many sciences, including mechanics, electronics, aerodynamics, and mathematics; and development of individual creative ability by original design work. These are all pertinent to engineering practice and have helped many to develop basic understandings for engineering problems.

It is a matter of record within NASA that model building and flying skills are a tremendous asset to our research personnel. Our apprentice programs since 1942 have given extra credit for these skills in considering applicants. Model building also aids those technical personnel, who continue modeling activities throughout their careers, in improving their capabilities and increasing their professional skills.

Besides the technical considerations, there is the environment of the model activity which encompasses associations which are in the highest traditions of American enterprise and democracy, cooperative research projects, moral values and character building.

The complementary aspects of modeling today are model aviation and model rocketry. Both contribute importantly to the advancement of our aerospace effort. The organizations, the Academy of Model Aeronautics and the National Association of Rocketry, both affiliated with the National Aeronautic Association, which are promoting modeling activities, have my wholehearted support.

Hugh L. Dryden
Deputy Administrator
National Aeronautics and
Space Administration
November 3, 1965

The rocketeer who plans on taking more than just a couple of pictures with his Camroc can save money by buying film discs in 6 packs and using a changing bag instead of buying film in film holders. Simple arithmetic shows that the long-run cost of the 6 packs is only half as much as the same amount of film in film holders. The first 8 pictures will save enough to pay for the changing bag--after that your savings are pure gravy.

When sending film away for processing, the 6 pack envelopes (the whole set) should be used. These envelopes are designed to serve two purposes. First, they can be used to keep the exposed and unexposed film separated while you're shooting. Second, when used as directed in the film instructions, they provide adequate protection to eliminate fogging of the film. PLEASE don't stick a film disc in a plain envelope, mail it in and expect to get a picture back. (Don't laugh--it's been tried.) If any light reaches the film during handling or shipping, it's ruined.

Although it's listed the same on the Clip 'n' Mail page, we've recently revised the "Introducing... Model Rocketry" brochure. The old edition was very useful to modelers looking for new

CAMROC...

Michael Abert...obtained this suburban shot from the school field at Irondequoit, N.Y. An Astron Delta was the launch vehicle powered by a B 3-7 engine. Though the sky was cloudy, the snow brought his contrast up for an exceptionally sharp shot.

Morgan McCune...may be proud of this vertical shot of his own home in Kennett Square, Penna. A two-stage Delta was used, powered by a B 3-0 - B 3-7 combination. Morgan got this picture for his school paper, and is working on a shot of the school for its yearbook.

Ronald Snodgrass...picked up this oblique shot of Metairie (New Orleans) La., using a B .8-4 powered single-stage Delta. Ron's father and a friend formed the launch & recovery crew. Ron plans to study the types of pictures obtained with different launch angles.

Jay Wells...got this late afternoon shot of a Canon City, Colo. residential area with a single stage Delta. Power was supplied by an Estes B 3-6. The flight went off after school. Jay's now working on a picture for his local paper.

Charles Wurtser...caught this beautiful oblique of Colorado's Rampart Range west of his home at the U.S. Air Force Academy. Coupling a B 3-0 - B 3-5 power package, Charles mounted his Camroc atop a two-stage Delta vehicle. Brothers Bob and Don and a friend witnessed this flight. As Charles does this just for his own pleasure, he should be well pleased with results such as this.

TRACKING ... continued

the baseline is 400 feet and the angle is 50°, the line will cross the altitude column at 480 feet. The nomogram also uses the principle of similar triangles. However, in this case the two triangles are both on the paper--one formed by the angle, 0' baseline point and 400' baseline point; the other formed by the angle, 0' altitude point and 480' altitude point.

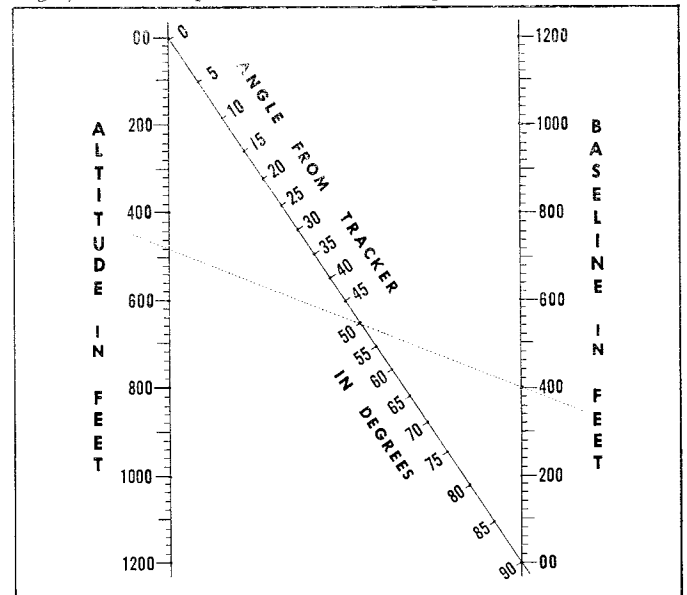

The advanced rocketeer will eventually find that these systems are not all he needs. When this occurs, Technical Report TR-3 will be good reading material. In fact, if you want more accuracy now, see TR-3: The methods described in this article should make other systems even easier to understand and apply. In the meanwhile, any of these systems will provide a quick and easy answer to your altitude calculating problems.

members for clubs and for explaining model rocketry to other hobbyists. The new version includes much the same explanation of the field, but it is considerably better illustrated and is a lot more colorful. A sample copy of this brochure is available on the same basis as plans and other materials on the Readers Service section of the Clip 'n' Mail Page (see the inside of this issue's wrapper). The brochure is sent free of charge to all who mail in the coupon with the appropriate square checked and enclose a stamped, self-addressed envelope. To make sure the material arrives in good condition, it's a good idea to send an envelope that measures at least 4" x 9".

FROM THE

CAMROC

EYE



Michael Abert

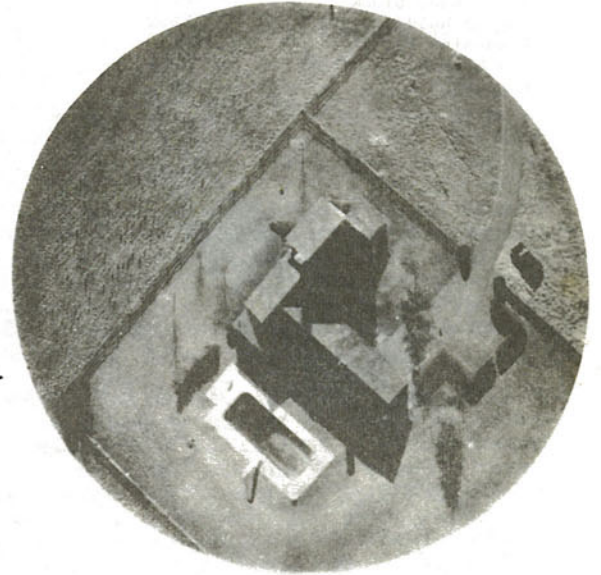

Morgan McCune

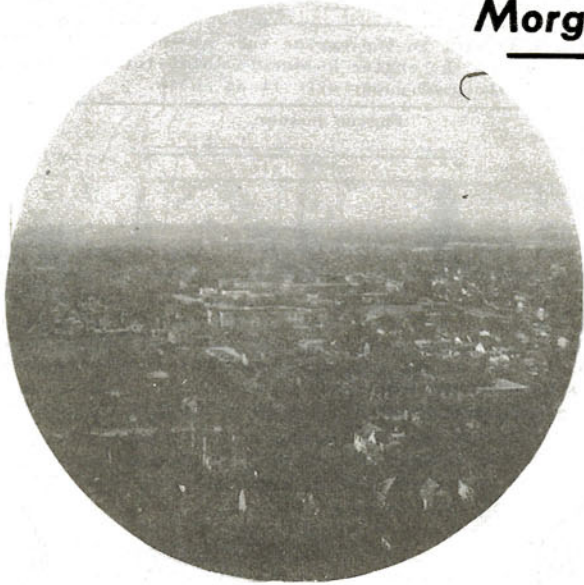

Ron Snodgrass

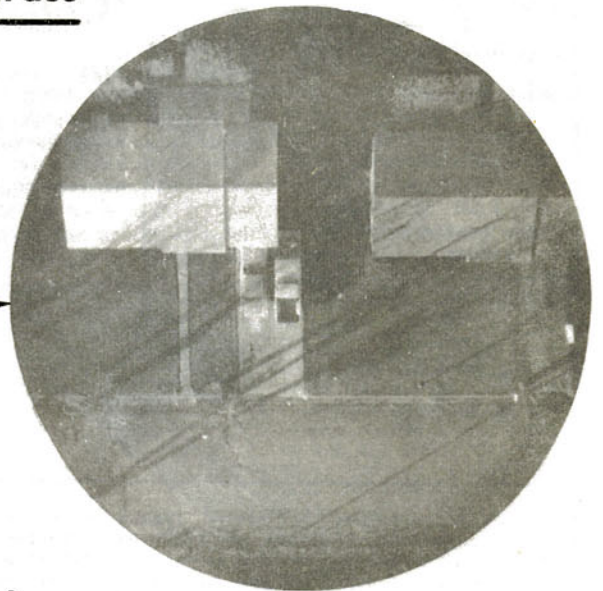

Jay Wells



Charles Wurster



See page 6, column 2 for more details.

Estes Industries Rocket Plan No. 38

GAMMA

with
REAR EJECTION 'CHUTE

Published as a service to its customers by Estes Industries, Inc. Box 227, Penrose, Colo. ©Estes Industries, Inc. 1966

PARTS LIST

- | | |
|----------------------------|---------|
| 1 Body tube cut to 12-1/2" | BT-55 |
| 2 Body tubes cut to 8-5/8" | BT-20B |
| 1 Sheet balsa fin stock | BFS-50 |
| 1 Balsa nose cone | BNC-55F |
| 1 Balsa nose block | NB-20 |
| 1 Engine holder | EH-2 |
| 1 Launching lug | LL-2B |
| 1 Shock cord | SC-1 |
| 1 Parachute kit | PK-12 |

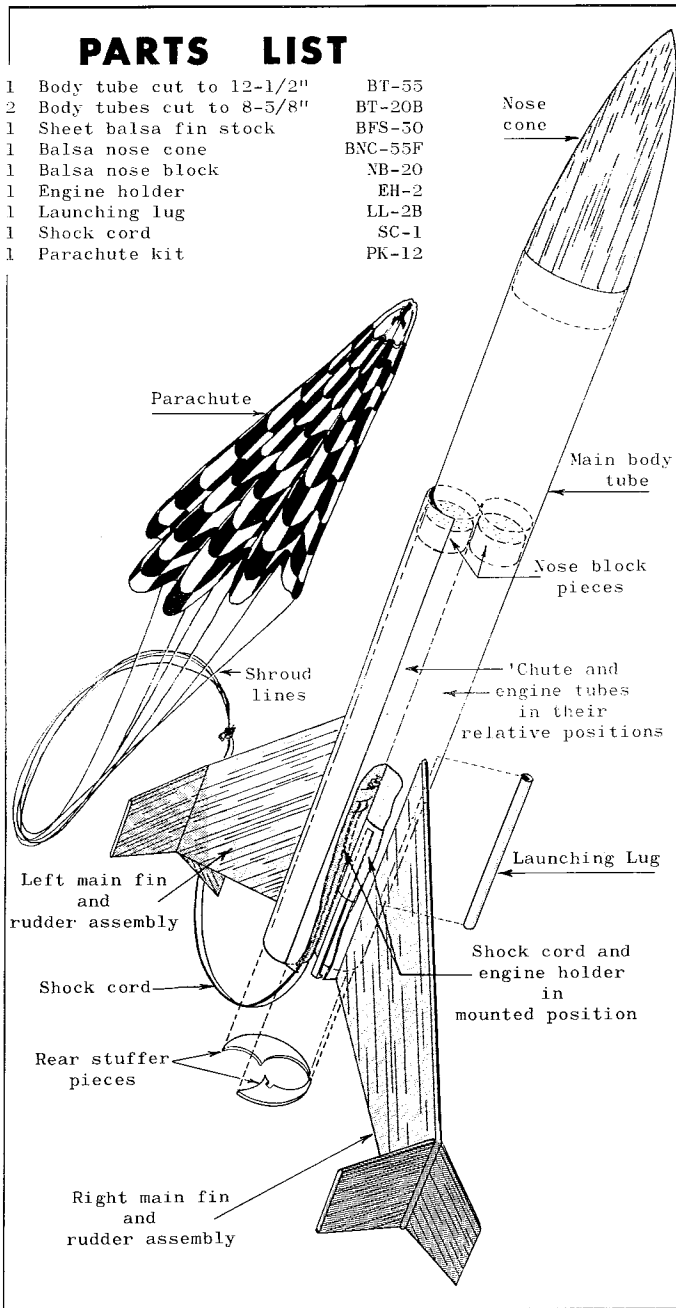

2. Cut a port in each tube 3/16" wide by 3/4" long. Use the marks crossing the centerline 5/8" from the tube end as the starting point as shown in fig. 2.

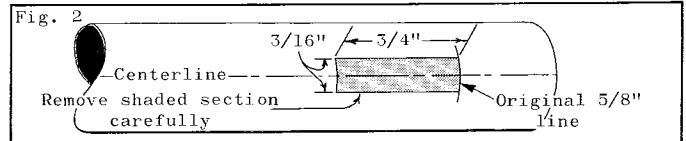

3. Cut the nose block in half. Spread glue inside one of the tubes at the port end, covering an area from 1/4" from the end to the edge of the port. Push one nose block piece into the tube until the inside end of the block reaches the edge of the port. Repeat this step with the other tube and the remaining nose block piece. See fig. 3.

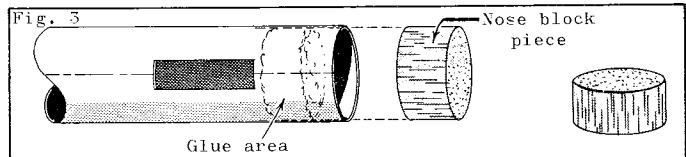

4. Cut a 1/8" slot in the engine tube at the 2-1/2" mark. Place one hook of the engine holder in this slot and glue a 1/2" x 1-1/2" strip of paper over it as shown.

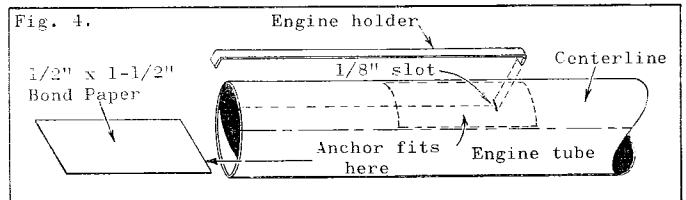

5. Cut 5 slits, each 1/4" long, in the other tube at the marks starting 3" from the tube end as shown. Tie a knot at one end of the shock cord and thread the shock cord thru the slots as shown in fig. 5.

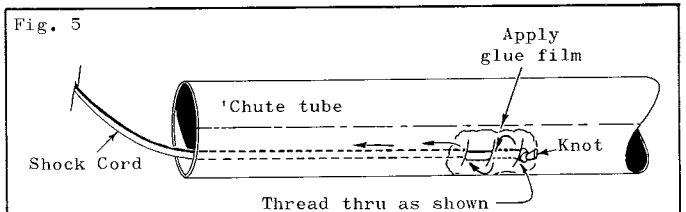

6. Apply a line of glue along the centerline of one tube in line with the port. (See fig. 6.) Carefully align the port of the "engine" tube with the port of the "chute" tube and join both tubes. Match the centerline marks on the ends of the tubes. After the glue has set, apply a good fillet of glue along both sides of the joint except in the area of the engine holder.

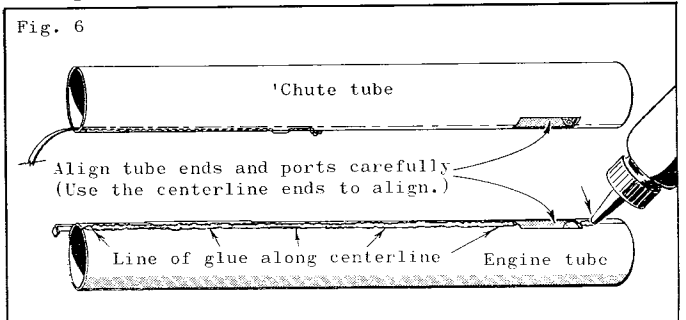

7. Cut a 12-1/2" long piece of BT-55 for the main body tube. Trace the body tube marking guide onto typing paper, cut out and wrap around one end of the tube. Mark the tube at each arrow point. Use a drawer or door sill and extend

1. Draw a centerline the entire length of both pieces of 8-5/8" long BT-20. Continue the lines onto the ends of the tubes. Select one BT-20 and mark it 2-1/2" from one end 1/4" above the centerline and across the centerline 5/8" from the other end. Label this tube "engine". Mark the other BT-20 3" from the end and 1/4" below the centerline as shown in fig. 1. Make two more marks 1/4" and 1/2" away from the 3" mark as shown and finally a mark across the centerline 5/8" from the other end. Label this tube "chute".

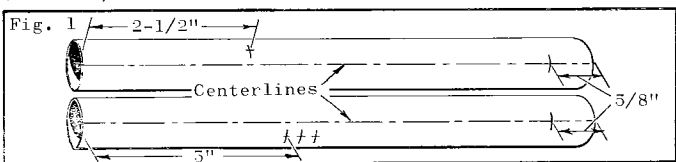

all marks about 9" forward along the tube. Select one of the lines drawn from the "X" arrow points, measure exactly 8-5/8" from the end of the tube as shown and mark the tube. Back up 1/4" and make another mark. Do the same with the other "X" arrow line. Draw a connecting line between the marks which are 1/4" back from the 8-5/8" marks. Carefully cut out the part of the tube as shown in fig. 7.

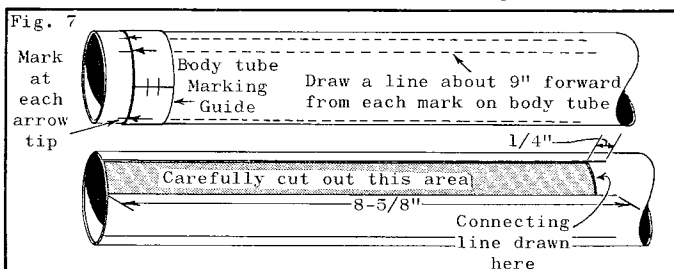

8. Apply glue to the inside of the main body along a line directly opposite the slot. Slide the engine-chute tube assembly into the main body tube with the recovery portion partly out thru the slot in the main tube. The forward end of the smaller tube must "seat" in the two 1/4" slits as shown below with the section of the main body tube against the nose block piece. Position the inside tubes so they are centered in the main tube. Apply a layer of glue to the seams along each side as shown. Support on a level surface until dry. Repeat as necessary to build up a strong smooth fillet.

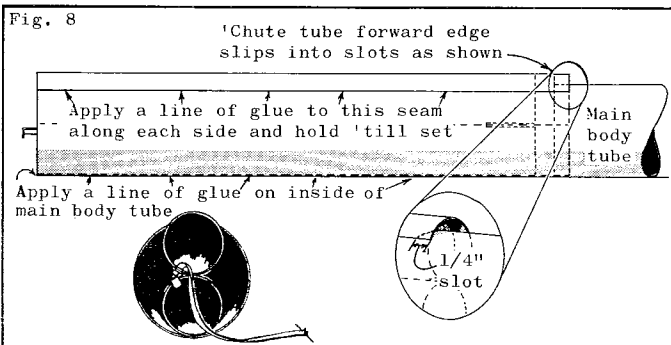

9. Trace the fin patterns onto stiff paper. Trace the rear stuffer pattern onto cardboard as directed. Cut out the tracings. Set the stuffer pieces aside and lay the main fin pattern on the balsa fin stock. Line up the wood grain with the leading edge and trace two fins. Do the same with the rudder pattern, making four pieces. Cut all the pieces from the fin stock and sand them as shown in fig. 9.

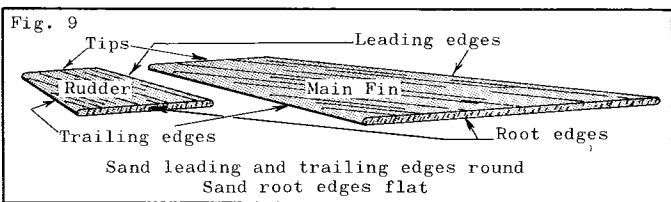

10. Glue the rudders to the tip of each main fin as shown. When the rudder joints have set, apply glue to the root edge of one main fin assembly and place it on a guide line next appearing to the right or left of the "chute" tube. Do the same with the other main fin unit and stand the model on its nose until dry. Apply a line of glue along the fin-body joint on each side and smooth it out into a fairing shape as seen in fig. 10. Support the model in a horizontal position until dry.

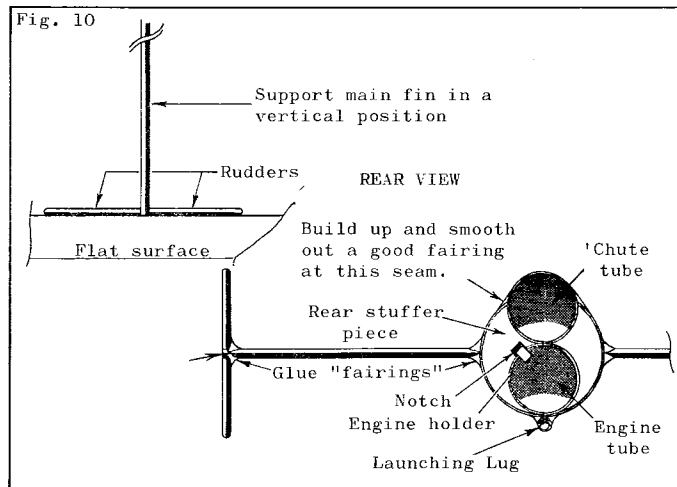

11. Glue one stuffer piece into place at the rear of the body tube on the side opposite the engine holder. Fit the remaining stuffer piece against its location and mark it on either side of the engine holder. Make a 1/8" notch (see fig. 10, rear view) to allow the engine holder to be sprung outward enough to release a spent engine casing. Glue the fitted stuffer piece in place taking care to get no glue on the engine holder.

12. Glue the nose cone in place. Glue the launching lug along the guide line on the underside of the body tube. Set the assembly aside to dry.

13. Assemble the parachute following the instruction in the kit. Tie the shroud lines to the free end of the shock cord. Pack the parachute, shroud lines and shock cord into the "chute" tube and temporarily seal the end of the tube with a bit of recovery wadding. The Gamma is now ready to be painted the color(s) of your choice.

Special Flying Instructions

14. Insert two squares of recovery wadding into the "chute" tube. Place the shock cord and shroud lines in next and the folded parachute in last. Push the entire mass 2 to 2-1/2" into the tube. Install any Series I single stage engine into the engine holder and your Gamma is ready for flight.

Pattern Group

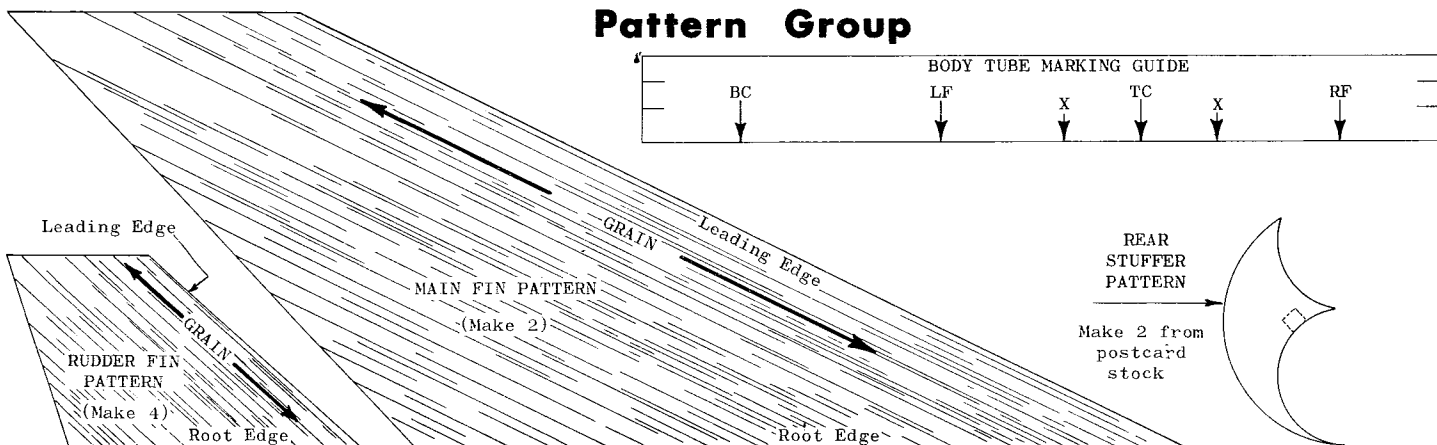

Estes Industries Rocket Plan No. 40

MITOSIS

Featuring
BREAKUP RECOVERY

Published as a service to its customers by Estes Industries, Inc., Box 227, Penrose, Colo. Estes Industries, 1966

The Mitosis uses the principle of breakup recovery. When the ejection charge is activated the nose and main body separate from the fin section. With a shock cord connecting the two pieces, each is unstable and the whole assembly flutters down to a safe landing. Since the model returns faster than it would by parachute, it generally lands close to the launcher, making it a good contender in spot landing contests.

PARTS

1	Rear Body Tube	2.75" long	BT-50J
1	Front Body Tube	7.75" long	BT-50H
1	Engine-holder Tube	3.5" long	BT-20G
1	Balsa Nose Cone for BT-50		BNC-50K
1	Stage Coupler for BT-50		JT-50C
1	Large Screw Eye		SE-1
1	Shock Cord	1/8" X 18"	SC-1
1	Engine Holder		EH-2
1	1/8" Sheet Balsa Fin Stock		BFS-40
1	Launching Lug	2-3/8" long	LL-2B
2	Ring Adapters	BT-20 to BT-50	RA-2050

CONSTRUCTION

Standard construction is used with the Mitosis with the exception of the steps individually illustrated below. Because this model will land harder than most parachute rockets, extra care should be taken to insure good glue joints. Accurate alignment of all parts is important for top performance.

1. Mark the BT-20G engine holder tube 2-1/2" from one end. Cut a 1/8" slot at this point as shown and fit the engine holder into place. Cut a 1" x 1/2" hold-down-strap from bond paper and glue in place.

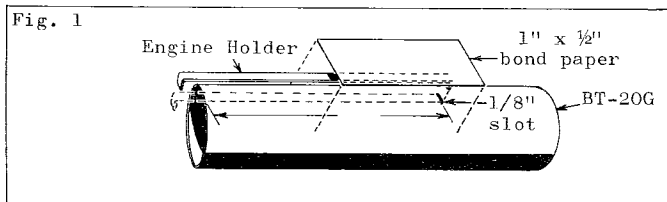

2. Tie a knot at one end of the shock cord. Lay it on the side of the engine holder tube opposite the front hook of the engine holder. Work a 2050 ring into the position shown. Cut a 1/8" slot in the other 2050 ring and place it centering the engine holder in the slot. Apply glue to the ring-tube joints and set the unit aside to dry.

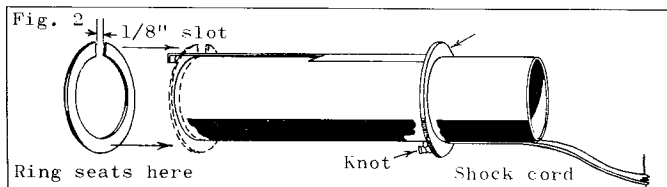

3. Mark the tube coupler 1/4" from one end. Apply glue just inside one end of the 2-5/4" piece of BT-50. Insert the coupler to the 1/4" mark as shown and make sure it is straight with the tube before the glue sets. Insert the engine holder tube (and the shock cord) into the other end of the body as far as it will go without forcing. Spread glue generously around the ring-body tube joint at the rear. Do not allow glue to flow into the engine holder slot. Set the assembly on the stage-coupler end while it dries.

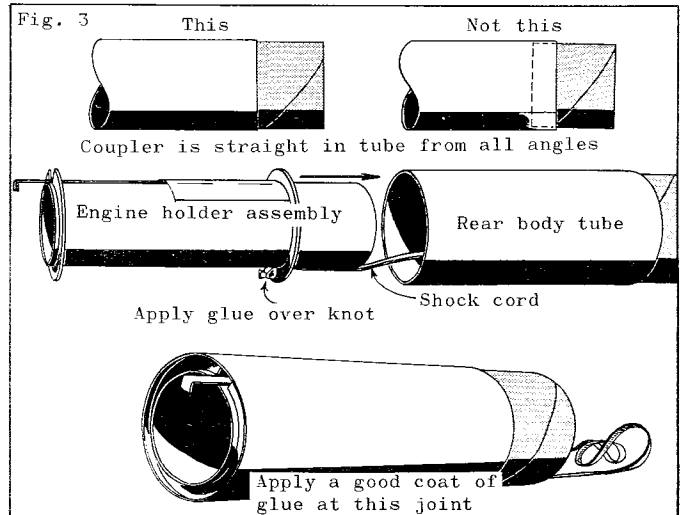

4. Trace the fin pattern onto stiff paper, cut out, and lay out 3 fins on the sheet balsa stock. Make sure the leading edge of the pattern is parallel to the grain of the wood. Cut out the fins with a sharp knife and sand the sides smooth, the leading and trailing edges and tips round, and the root edges flat.

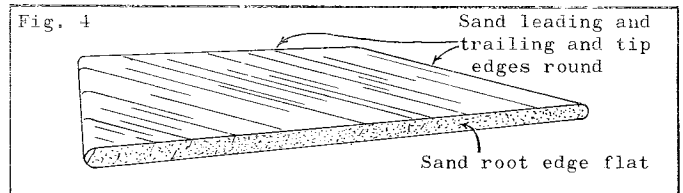

5. Trace the tube marking guide onto typing paper. Cut it out and wrap it around the rear body tube. Mark the tube at each of the arrow points. Use a door or drawer sill for a straight edge and extend the marks the length of the tube.

6. Glue the fins in place as shown in the overall view. Attach the launching lug to the front body tube as shown. Insert the screw eye into the base of the nose cone, remove it, squirt glue into the hole and replace the screw eye. Thread the shock cord thru the upper body tube tie it onto the screw eye. Glue the nose cone into the front body tube. Your MITOSIS is now ready for painting and flying.

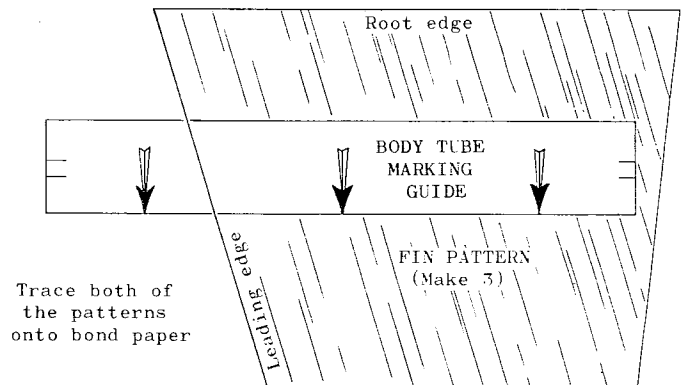

HIGHLIGHTS OF THE Pittsburgh Convention

The first regional model rocket convention was held March 11-13, 1966 at the Shady Side Senior Academy, Pittsburgh, Pennsylvania. Some 150 rocketeers from nine states were present, along with representatives from the National Aeronautics and Space Administration, the National Association of Rocketry and Estes Industries.

The convention was arranged by the Steel City Section of the NAR. Convention leaders included Jay Apt, Arnold Pittler and Elaine Sadowski, all of Pittsburgh.

Discussion groups, both formal and informal, were numerous throughout the convention. Model rocketry, past, present and future, was the central theme of the sessions. Special discussions on the fundamentals of model rocketry, model rocket design, model rocket stability, forming clubs and keeping clubs active drew the greatest attention from those attending.

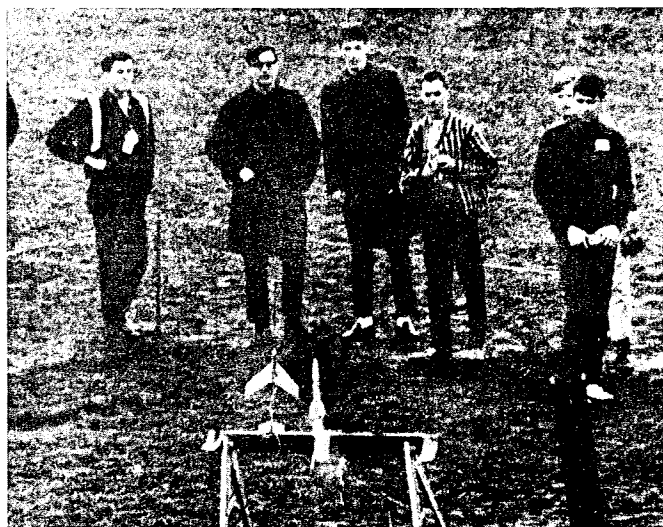
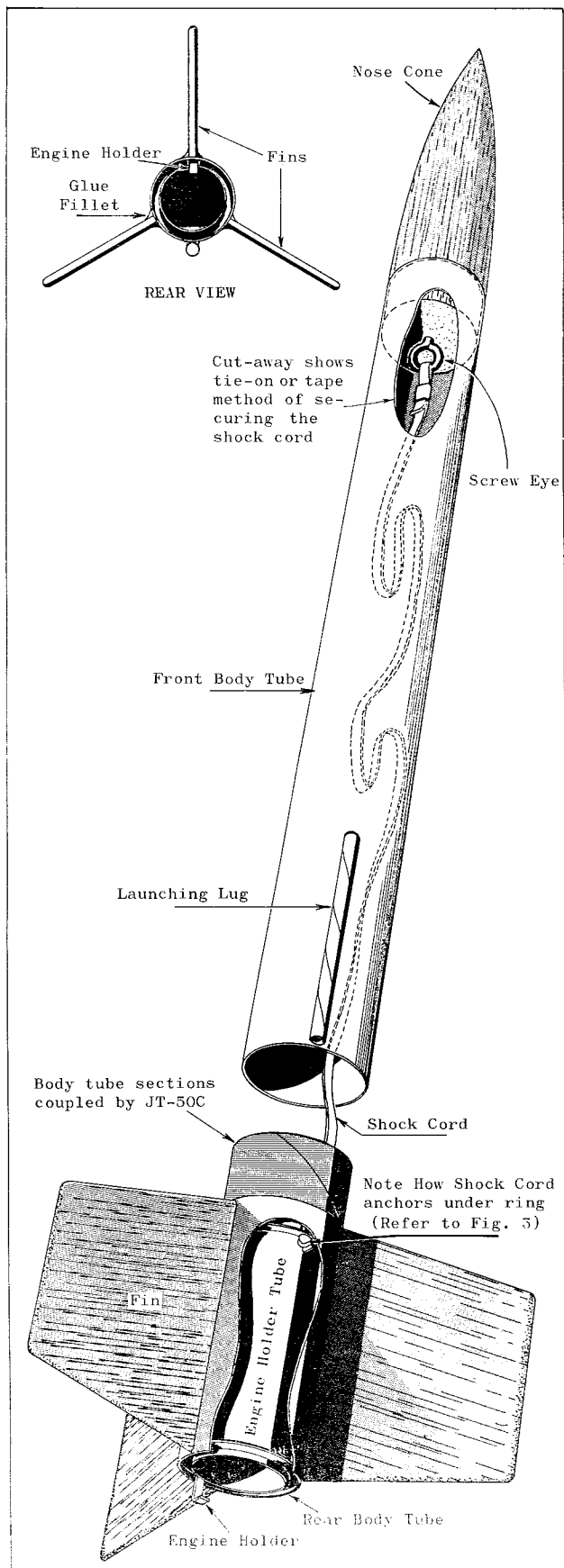

A launch session was held Saturday afternoon with a group of representative models flown. Familiar sights were the Streak, V-2, Camroc, and even the Buchanan Buster. The Camroc was especially well represented with six different ones counted. Many home designed birds were flown. The Pittsburghites were visibly impressed with both the achievements of the models and the safety shown by the launch and recovery crew. The flights had to be cut short because of wind and rain.

Sunday afternoon seemed to come all too soon for the rocketeers. It had rained off and on from Friday night through Sunday, but this didn't stop any of the interest and the rocketeers left for their homes a little tired but with unbounded determination to create new and better rockets and rocket clubs.



are two accepted procedures used here, and the modeler should experiment to see which will work best for him. One way is to simply pull the tape up. The other is to carefully scribe along the edge of the tape with a sharp knife blade before pulling it up. In either case, the tape should be peeled off by pulling almost parallel to the rocket surface as shown. When the paint is completely dry, sand the edges of the second color very lightly with very fine sandpaper.

A third color is applied in the same manner as the second, with the areas which are to remain the first two colors masked over. Often it is best to leave the masking which protected the first color in place and add more masking to protect the second color area. In this way it will not be necessary to try to line up another piece of tape with the edge between colors.

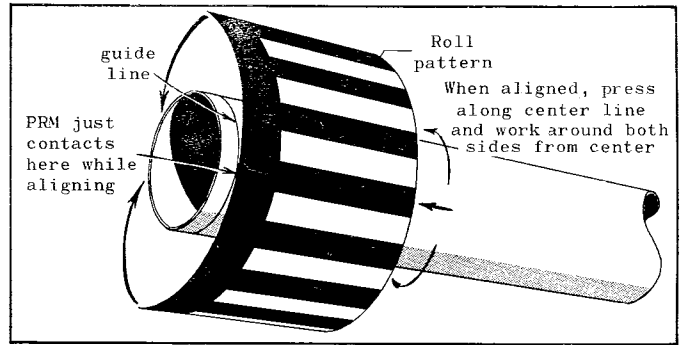

When a model has been finished with fluorescent paint it helps to apply a light coat of clear spray before adding decals or tape. The clear coating keeps the paint from rubbing, pulling or washing off. It is generally best to apply several coats of clear to the entire model after the decals have dried completely, whether the paint is fluorescent or not. The clear coats seal down the edges of the decals and help prevent chipping and peeling. Do not, however, apply any type of butyrate dope over decals. The dope will partially dissolve and distort most decal materials.

Before applying wax, be sure that any fluorescent paint is covered with several coats of clear. Waxing will smear unprotected fluorescent paint. The same precaution should be taken with most metallic paints. Unless the surface is perfectly smooth, the rocket should be worked over with automotive rubbing compound. Enough compound to last for hundreds of models can be bought at most hardware and auto supply stores for less than a dollar. Work the compound into a wet rag, rub down the entire surface of the model, let the material dry and wipe it off with a clean dry cloth. This will remove the tiny rough spots which cut down the shine of the surface.

Wax should be applied with a clean, soft cloth. Only a very thin layer is needed; if too much is applied it will be wasted. Polish with another clean, soft, dry cloth. The type of wax sold by Estes Industries should be polished immediately after application. Most other waxes should dry before polishing. Waxing does not make a surface particularly smoother--what it does do is protect the smooth surface below. If the rocket doesn't shine as much as you'd like after waxing, the best thing to do is work the rocket over with rubbing compound again before rewaxing.

By practicing finishing the right way and paying close attention to detail, the modeler can produce a professional quality finish. Some modelers, in fact, will produce better than professional finishes.

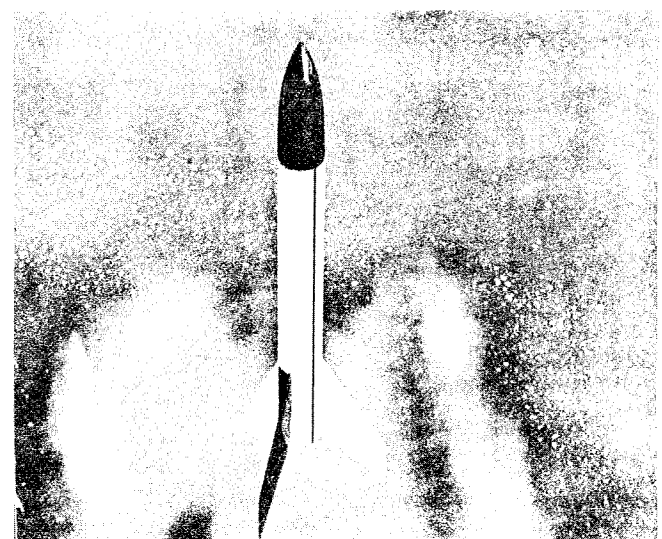

Enamel paint may be applied over butyrate dope, but NEVER APPLY BUTYRATE DOPE OVER ENAMEL PAINT. If in doubt, test the compatibility of different paints on a piece of scrap material.

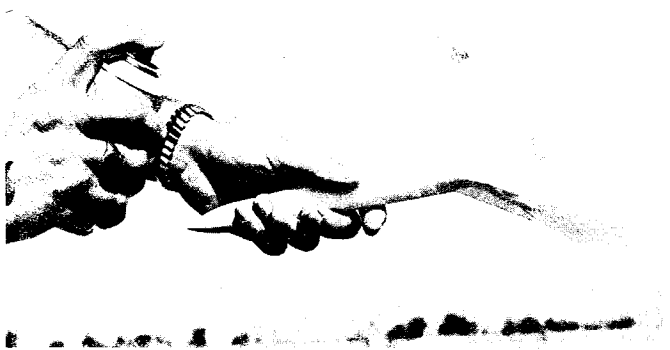

Final Touches

Decals should be applied following the instructions which come with the decal sheet. Soaking times and handling methods will vary slightly. However, in almost all cases the decal should be slid on the backing so one edge is barely off the paper. This edge is then positioned against the rocket and held in place with a finger. Pull the backing sheet out from under the decal and smooth it down, removing any bubbles. Blot away excess water with a rag.

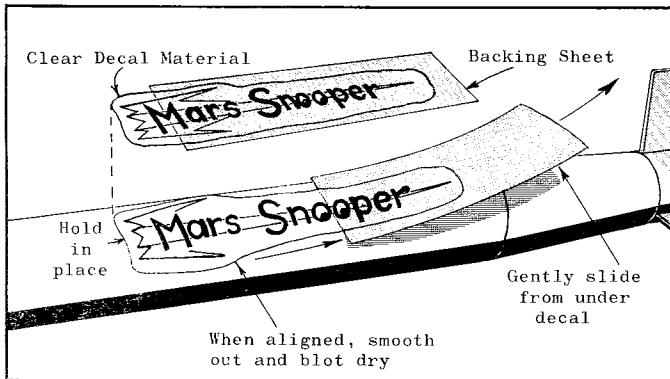

Roll patterns, stripes and bands may be applied with either decals or decorating tape. The pieces should be cut to size before application. When using decorating tape narrow stripes can be made by laying a length of tape, adhesive side down, on a smooth, hard surface and cutting the correct width with a ruler and sharp knife.

A roll pattern may also be produced by drawing the design in India ink on PRM-1 adhesive paper. The length of the piece should be determined by wrapping a sheet of paper around the body and marking the point at which it meets itself. This distance is then marked on the PRM, divided into the desired number of equal parts and the design inked in. Regular drafting equipment (T-square, triangle, etc.) should be used when producing a pattern this way. After making the design, cut it to size, strip off the backing paper, carefully align the pattern with the rocket body, press it into place at the middle and wrap the ends down.