

# MODEL ROCKET NEWS

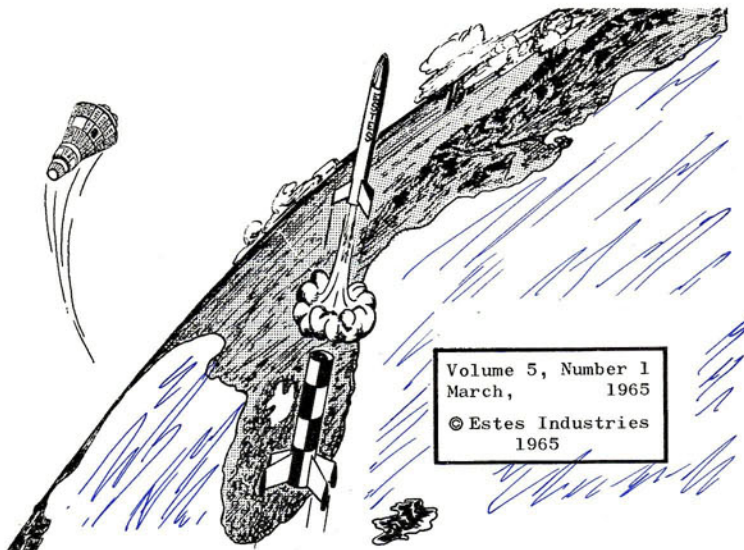

## Displaying Your Models

No matter how good it may be, a model rocket can't spend all its time flying. For the modeler who has collected very many rockets, the question becomes what to do with them between flight days. Certainly they can just sit on the table, shelf, cabinet or floor, but that's the lazy way out.

Ideally, any method of storing models should not only protect them from damage, but should also advertise the builder's hobby effectively, show off his skills and decorate his living quarters. The best means of accomplishing all this depends on the individual and the area in which he is storing his rockets, but a general outline of some of the methods used can be helpful in deciding how to get the best results.

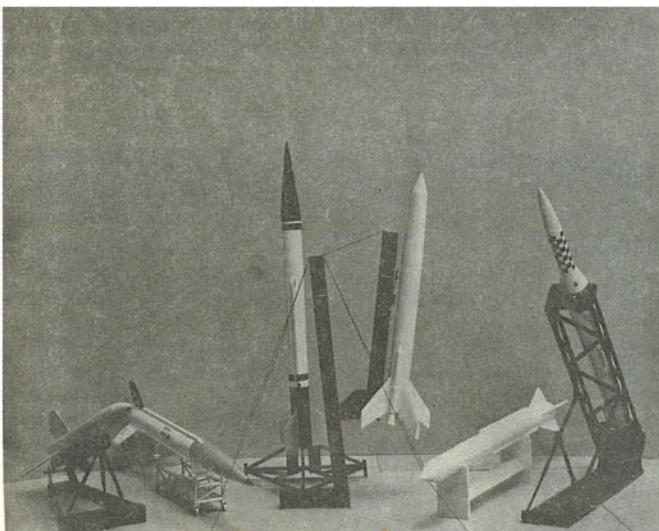

The most common means of displaying rockets is to set them on their fins on a shelf. Actually, this is much like arranging flowers in a vase—there are right ways and wrong ways to do it, and it takes an artist to get the very best results. The first rule of arrangement is that the display must be orderly. The second rule is that the container (shelf) must harmonize with the display.

To highlight the rockets, the shelf should be well finished and blend well with the room's other furnishings and with the models themselves. The models must be positioned in a logical order.

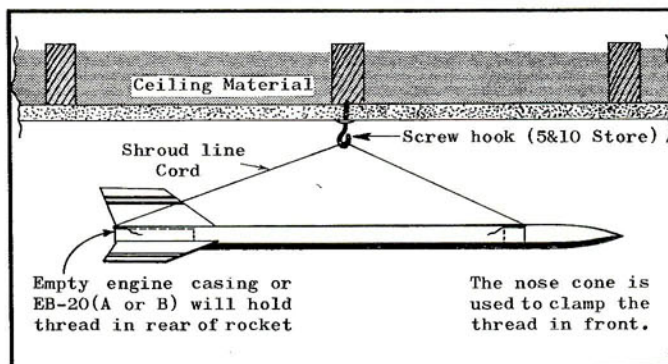

Typically, large models might be placed at the fringes, small ones at the center. An exceptionally good model (or trophy) might be placed at the center and the other models positioned to lead attention to it. The best bet is to experiment until a balanced arrangement has been achieved.

Carefully selected space-related pictures clipped from magazines can be used as a background for models on the shelf.

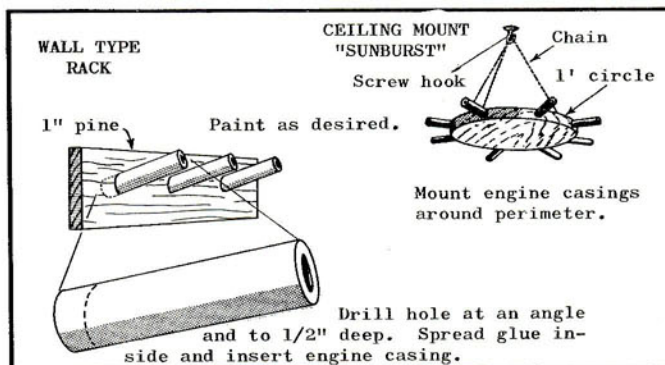

When placing other items on the shelf, it is important to select only those which fit in well with the original theme. For example, if the display consists primarily of boost-gliders, pic-

tures of vehicles such as the Dyna-Soar, Asset, M-2, etc. would be appropriate.

In most rooms the greatest part of the empty space available for rocket storage is the top foot between floor and ceiling. Any fixture already mounted on the ceiling can be a convenient support for models. To mount the rocket, hook a piece of thread about 1-1/4 times the length of the model through any handy spot, clamp one end of the thread in between the nose cone and body tube and clamp the other end in the rear of the rocket with an empty engine casing. It is advisable to make sure that both ends of the thread are held securely to avoid catastrophe.

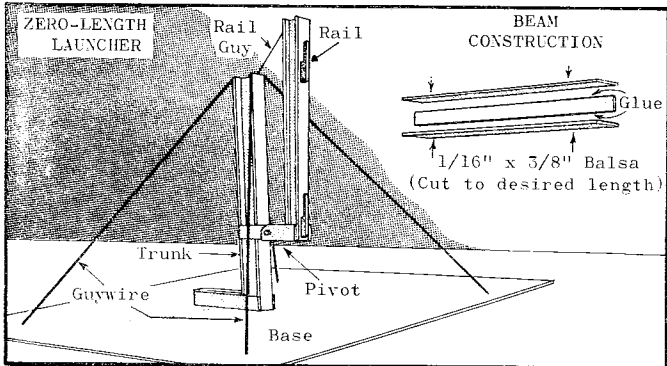

If you can get permission, screw eyes placed in the ceiling at strategic points will provide additional spots for hanging models. Of course, rockets can be hung from rockets, but normally two layers are enough—too many and they will get in the way. While models can be hung at random points around the ceiling, some consideration should be given to the possibility of placing them in formation.

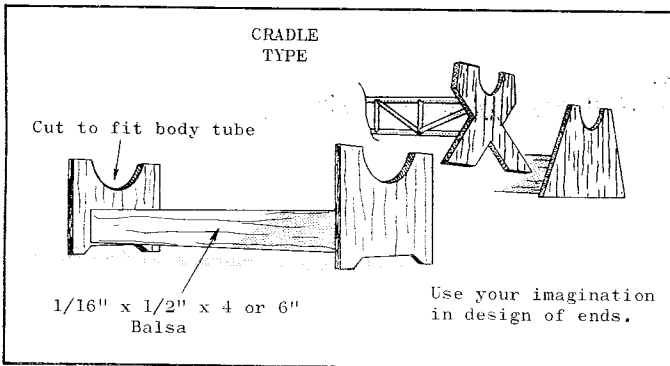

NASA for quite a variety of sounding rockets, but is not quite a scale model of any one in particular. The main pieces are two I beams made of 0.4" wide strips of balsa. With the base support, a pair of pieces to mount the short beam on the long one, a pair of hooks to fit into the launching lugs of the model, and some thread, the model goes together rapidly and adds to the scale appearance of the rocket that is stored on it. (Don't try launching rockets from it, though, as it will not guide the rocket sufficiently to give a straight, predictable flight.)

For versatility, the cradle is hard to beat. It can be used as a support for models on the shelf or during construction. One cradle can be used with many different models (one at a time, of course). Standard construction uses two end pieces that are cut to allow a body tube to fit half-way in and two connecting pieces to space the end pieces 4 to 6 inches apart. With a bit of imagination, the cradle can be built to resemble the ones used with full-size rockets during construction.

To support models vertically, a variety of holders can be designed. All will normally consist of two parts, a base and a core. Engine blocks, stage couplers, empty engine casings or any other object that will fit up into the rear of the rocket to hold it will work as cores. The base can be simply a 4" square of cardboard or it can be built of balsa strips, dowels and toothpicks to make as elaborate a stand as you want. For larger models larger bases will be needed. As a general rule, the distance across the base should be at least 1/3 the length of the model to provide adequate support.

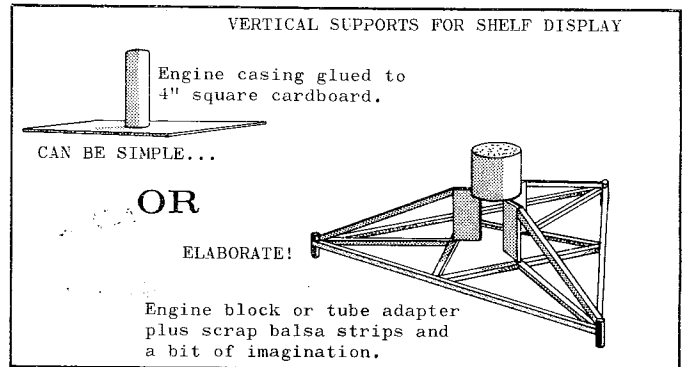

Once a storage system--shelf, wall or ceiling--has been set up, it's easy to maintain. You'll have no difficulty finding a model when the time comes to fly it. As the rocket fleet grows additional models will take their place on display, adding to an impressive and ever-expanding record of workmanship and achievement.

A third approach to rocket storage is the rack. The "rod roost" (see Vol. 4, No. 3 of the Model Rocket News) is one of the simplest forms of rack, consisting of a board and several dowels set at a slight angle to support the model. The dowels may be replaced by empty engine casings and the models supported by sliding them down over the casings. The proper size for such a rack will depend on the size and number of models to be stored on it.

The eye appeal of most displays can be increased by the use of carefully selected accessories. Cradles and dummy launchers are some of the most effective devices for adding extra realism to models. They also help protect the models in many cases by providing a more rigid support.

Left-over pieces from kits and other projects are the ideal raw materials for constructing special rocket supports. Looking through books and magazines, one can find many pictures of the gantries, launchers and transporters used on full-scale rockets. With a little patience and ingenuity, it's a simple matter to construct a good looking replica--or even design one to "look more real than the real thing."

The zero-length launcher is a good illustration of what can be produced in an evening. It is based on the launchers used by

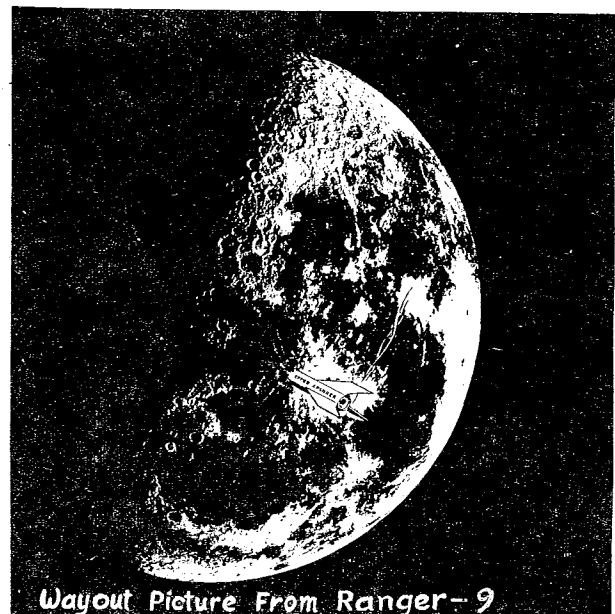

Wayout Picture From Ranger-9

# Astron X-Ray

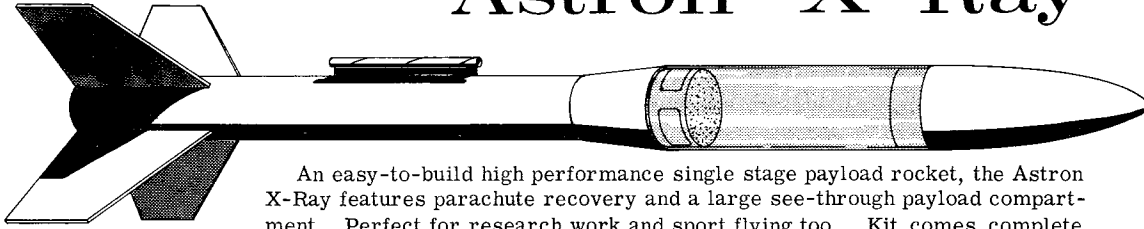

An easy-to-build high performance single stage payload rocket, the Astron X-Ray features parachute recovery and a large see-through payload compartment. Perfect for research work and sport flying too. Kit comes complete (less engines). Shipping wt. 6 oz.

**Only \$1.75**

**Cat. No. 641-K-18**



**Cat. No. 641-PS-20C**

**\$.85 each!**

Large size clear plastic payload compartment kit for BT-20 rockets. Measures 0.95" diameter by 3" long inside, overall length is 7". Includes all parts plus extra launching lug and balsa standoff for rocket body. Net wt. 0.4 oz., shipping wt. 4 oz.

## New Products

Modernize early model Electro-Launches with this compact control panel kit. This is the unit featured on the new Electro-Launch II. Replaces the old spring switch, adds safety interlock and continuity check light to your system. Easy to assemble, comes complete with 6 volt pilot light. Shipping wt. 6 oz.

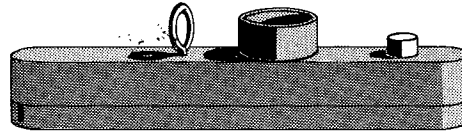

**LAUNCH CONTROLLER**

**Cat. No. 641-FFS-4**

**\$1.50**

### WHY MODEL ROCKETRY?

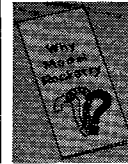

A 28 page booklet presenting clearly why model rocketry was developed. An ideal aid to explain your activities to a non-modeler. Shipping wt. 2 oz.

**Cat. No. 641-BK-1**

**\$.20 each**

### BNC-5S

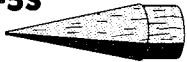

Extra-light weight balsa nose cone, 1.7" long overall, 1.4" extends outside of body Fits BT-5P. Net wt. 0.025 oz. Shipping wt. 1 oz.

**Cat. No. 641-BNC-5S** **\$.25 each,**  
**3 for \$.50**



### BT-5P Body Tube

Spiral wound 5.1" long, 0.515" I.D., 0.541" O.D. body tube. Use with BNC-5S and TA-550 for special payload sections. Net wt. is 0.062 oz. Shipping wt. 4 oz. **\$.15 each,**  
**Cat. No. 641-BT-5P 3 for \$.30**



### TA-550

Light weight balsa adapter mates BT-5P to BT-50. Taper is 1" long, overall length is 2.24" Net wt. 0.059 oz. Shipping wt. 4 oz.

**Cat. No. 641-TA-550** **\$.35 each**

### BATTERY CLIP



Spring brass battery contact clips--ideal for making special battery installations. Replacement part for the Electro Launch II clips. Fits size D cells, can be trimmed to fit smaller sizes. Shipping wt. 1 oz.

**Cat. No. 641-BC-2 2 for \$.20**

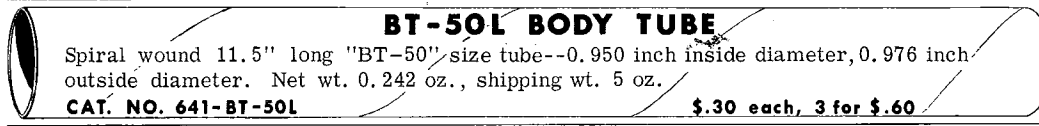

**BT-50L BODY TUBE**

Spiral wound 11.5" long "BT-50" size tube--0.950 inch inside diameter, 0.976 inch outside diameter. Net wt. 0.242 oz., shipping wt. 5 oz.

**CAT. NO. 641-BT-50L** **\$.30 each, 3 for \$.60**

## MODEL ROCKET NEWS

The Model Rocket News is published four times annually by Estes Industries, Inc., Penrose, Colorado. It is distributed free of charge to all the company's mail order customers from whom a substantial order has been received within a period of one year. The Model Rocket News is distributed for the purpose of advertising and promoting a safe form of youth rocketry and for informing customers of new products and services available from Estes Industries. Rocketeers can contribute in several ways towards the publication of the Model Rocket News:

- (1) Write to Estes Industries concerning things you and your club are doing in this field which might be of interest to others.
- (2) Continue to support the company's development program by purchasing rocket supplies from Estes Industries, as it is only through this support that free services such as the Model Rocket News, rocket plans, etc., can be made available. This support also enables the company to develop new rocket kits, engines, etc.
- (3) Write to the company about their products and tell what you like, what you don't like, new ideas, suggestions, etc. Every letter will be read carefully, and every effort will be made to give a prompt, personal reply.

Vernon Estes  
Publisher

William Simon  
Editor

## Help Wanted - - -

To Develop our Educational Program

Estes Industries has long recognized the educational potential of model rocketry and its associated fields. Now that this scientific hobby is becoming more widely known its merits in the field of education are being recognized by many others. As a result there is an ever increasing need for prepared materials for classroom use.

To meet this need Estes Industries is searching for just the right person--someone with a teaching background and an interest in the educational needs of tomorrow's scientists and engineers, someone who enjoys science himself, is already interested in model rocketry and doesn't mind working long and hard in promoting the most valuable aspect of the hobby. He should enjoy living in a small town and be free to move to the Penrose area.

Anyone who is interested in this long term position should contact us by mail. Application procedures will be mailed out upon request to:

Personnel Dept.  
Estes Industries, Inc.  
Box 227  
Penrose, Colorado 81240

A brief mention of your interests or background with the initial correspondence would be helpful.



# NOTES FROM THE BOSS

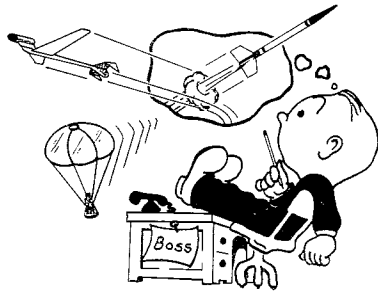

Many thanks to those who filled out and sent in the questionnaire from the last issue of the MRN. We appreciate your interest and your help. A special note of thanks to you parents and teachers who sent letters along--we're very glad to find out what you think about model rocketry and we value your comments very highly.

How big is too big? When your friend Herkimer starts to plan a 7 stage, 21 engine "model" rocket, do you encourage him or discourage him? What about that "little" 4 stage bird with only 4 engines?

As a general rule, we recommend no more than 3 stages, no more than 4 engines in a cluster and never a mixture of clustering and multi-staging. Why? Reliability decreases as complexity increases.

With multi-stage rockets using up-to-date staging techniques, there would be nothing wrong with a 4 stage model except for two minor problems. First is trying to keep an eye on the upper stage and all the boosters, and second is a little item known as dispersion. With an unguided, fin stabilized rocket, there is no control over the angle of flight after the rocket leaves the rod except for its natural stability. The effects of wind, launch angle, drag, etc., multiply so that by the time the fourth stage burns out, the rocket is often traveling horizontally. With a three stage rocket, these effects are not so severe and the rocket will, if the right engines are used, follow a considerably more vertical path. As a result, the 3 stage model reaches a higher altitude than the 4 stager, doesn't travel as far horizontally and is recovered. This has been observed in several actual tests.

Series II engines in the lower stages will reduce dispersion, but they also reduce altitude in most rockets, since they burn out sooner, letting the rocket start decelerating at a lower altitude (check it out for yourself--see Vol. 4, No. 2). When all things are considered, 3 stages give more results for the money than 4 or more.

With cluster rockets, the problem is ignition reliability. Jetwick is unreliable at best, and the power requirements for all-electric ignition make more than 4 engines extremely difficult to ignite simultaneously. The fewer engines used, the better the chances for a good flight. Combine the problems of clusters and multiple stages, and you have a rocket that is best left on the shelf to collect dust.

The rocketeer who wants to do extensive payload research at higher altitudes has two choices. He can invent and perfect systems for increasing the reliability of complex models, or he can design his payloads to fit reasonably-sized rockets and design his rockets for maximum efficiency. The second course is both easier and more productive. It would be safe to say that the "grapefruit" of Vanguard I taught us more of importance about the earth and space around it than any single Saturn I launching to date. In the same way, the small, well-designed payload in the smaller rocket can teach the model rocketeer more than the overgrown monster. Certainly, it takes more thinking to perfect a payload and clean up a rocket design than it takes to stack stage upon stage, but the well-designed system is more reliable and less expensive in the long run.

We had hoped to get Catalog #651 printed and mailed out by now, but we've been having trouble finding suppliers for some of the items. It'll be out soon, but just how soon, we can't say for sure. In the meantime, we'll try to keep you posted on the more important new products through the MRN.

# LETTER SECTION



Dear Mr. Estes,

I enjoy your company's products very much, but I think there are several drawbacks to our launch location. About a week ago my friend and I were launching at our only available launching site (which is just a cow pasture behind my friend's house). While we were busy recovering Craig's (my friend) rocket which had very conveniently landed in a tree, a cow had been wondering what was going on over at the launcher. When we came back we noticed the cow investigating the launcher so we hurried over to make sure she didn't do anything drastic. But we were too late--the cow had eaten two fins of one of my rockets, tried a lick of Craig's camera lens, sampled a bit of the accumulated carbon on the launcher, demolished half a bottle of our talcum powder and had also trampled Craig's firing panel and batteries.

Jay Roberts  
Amherst, Mass.

Sirs:

It appears that our organization is unable to supply the type of information which you desire through your questionnaire.

We use your materials for demonstration purposes and to promote safe rocketry experiments.

We have used your materials for the past three years in our program and have found them to be completely reliable, safe, and satisfactory.

We trust that you will keep us on your mailing list.

Dr. Ernest D. Riggsby, Director  
Aerospace Education Institute  
Troy State College  
Troy, Alabama

(Educators and educational institutions will find they have a rough time getting off of our mailing list. We're very glad to see people like Dr. Riggsby working to make space-age education interesting, and we'll do everything we can to help them. Ed.)

Gentlemen:

I would like to know if your company sells the ejection charge alone.

I would like this information because I am building a destructable rocket, a rocket which will explode in its peak altitude.

(Name Withheld)  
Wahiawa, Oahu, Hawaii

(We do not sell ejection charge alone and do not recommend building a "destructable" rocket. There's a good chance that in case of any malfunction such a rocket would "destruct" the rocketeer. Alternately, it could "destruct" his neighbor's house or start a dangerous fire.)

A model rocket, by definition, must be recoverable in re-flyable condition. A destructable rocket does not meet this requirement---it is not a model rocket, but a basement bomb! The progress of model rocketry depends on the individual rocketeer's good judgement--so before you start on a far-out project, think! Ed.)

# THE IDEA BOX

## TOOLS...

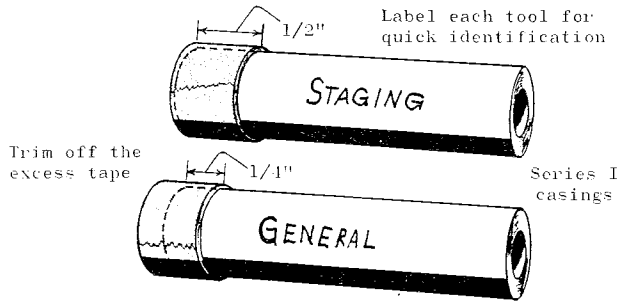

## Get Positive Engine Placement

Get the right engine block position for sure with one of these gauges. A few layers of 1/2" masking tape wrapped around one end of an engine casing makes engine block installation a deft one-move operation without fear of freezing out of place. The 1/2" unit gives proper positioning for upper stages; the 1/4" unit allows the engine to be taped to the engine tube for easy installation and removal.

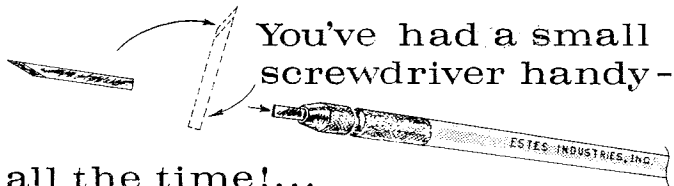

... If your tools include a #1 handle and a KNB -1A blade. Just reverse the blade as shown and this "screwdriver" will perform as well as any factory built job of comparable size.

In addition, the #1 handle can be used to hold twist drills from the smallest one up to 5/32" diameter without modification. Careful reaming will adapt the #1 handle to hold a 1/8" bit. Masking tape is used to secure the smaller bits as shown below.

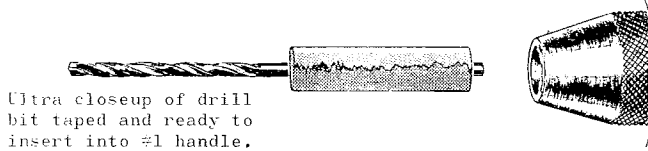

## FOR MARKING GUIDE LINES...

No longer is a drawer or door sill needed to draw the guide lines parallel to the centerline of body tubes. Most



Hardware stores have aluminum angle strips in the "Do-it-yourself" supplies. Select a piece having at least 1/2" sides and cut it to 4" or 6" long. Sand off the cut edges on each end with medium or coarse grit paper and you have a tool for a variety of jobs requiring a metal straightedge. For marking guide lines, set the angle piece on the tube as shown.

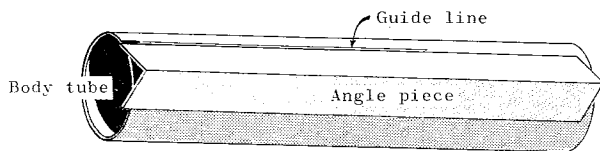

Line up edge with mark from spacing guide and draw line

## Battery Boxes for Any Special Purpose Easily Made with the New ESTES BC-2 Spring Clip

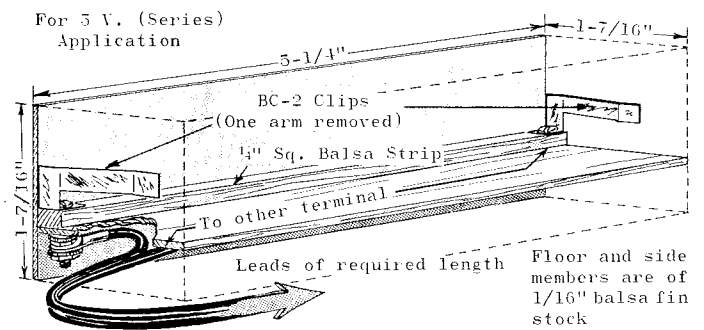
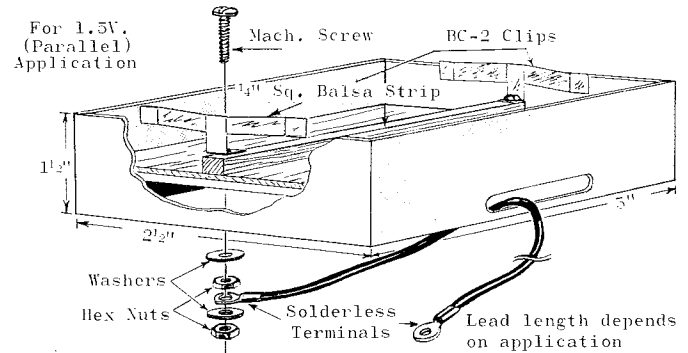

## Many Have Suggested This...

Increase the chances of having your bird returned in good condition by putting your name and address on the body of the rocket or under a wing panel of a boost glider. A piece of PIR-1 makes a good "nameplate".

Print contact or mailing directions, REWARD (if any), then name and address. Trim to size, remove backing paper and stick in position.

PLEASE RETURN TO OR CONTACT THE OWNER OF THIS ROCKET. REWARD!  
JOE P DOAKS  
1342 RUNNINGWATER AVE.,  
MINIKAWNAW, PENNA.

## Sand 'em all the same shape!

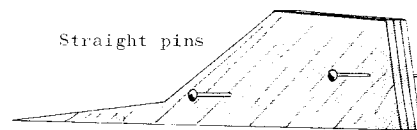

Straight pins help you to flat-sand all fin edges to a common shape at one time. Stack 'em together and push a pair of pins through them all. When sanded, remove the pins and sand each fin to its final airfoil shape.

## Straight Edges Easy with Block-sander You Can Make

Make a block sander by taping a 5" by 5" sheet of sand paper to a block of wood the size shown. Watch the quality of your work improve as you use this tool more and more.

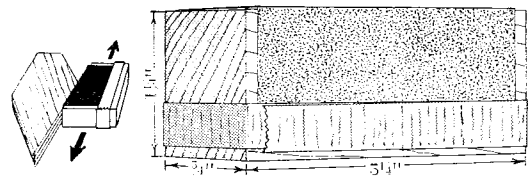

4. Lay the patterns on the balsa sheet (if you did not trace them directly). Make sure the grain direction is correct. Cut out the fin and landing gear pieces. Sand the fin pieces until the sides are smooth and all but the root edges are rounded. Set the landing gear pieces aside for now.

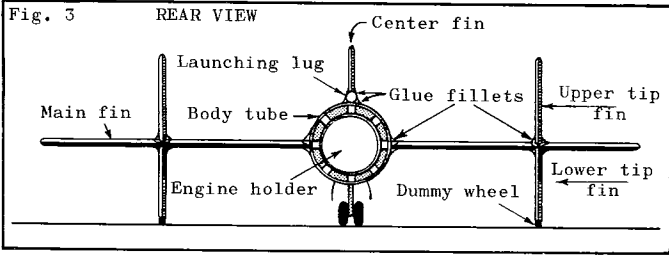

5. Mark the body tube for the positions of the main fins, launching lug and bottom centerline. Draw guide lines from these marks so that all lines parallel the tube centerline. Smear a liberal amount of glue 1-1/2" up into the rear end of the body tube. Push the engine holder assembly into place until the mark (made as in Fig. 2) on this assembly is even with the rear of the body tube. Glue the launching lug and the main fins in their positions and stand the assembly aside to dry.

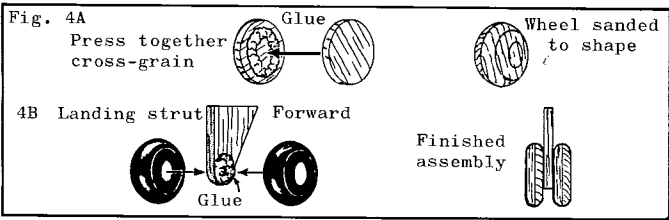

6. Glue two wheel halves together so their grains cross at a 90° angle. Do the same with the other two wheel halves. When dry, sand the wheels to the shape shown in Fig. 4A. Glue the wheels to the landing strut and set aside to dry. (Fig. 4B)

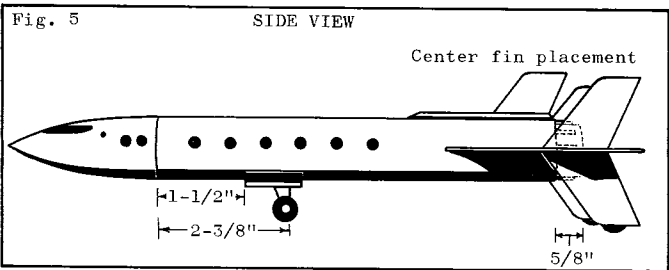

7. Apply glue to the root edges of the upper tip fins and position them on the topside of the main fins on the location marks. Glue the center fin into place on top of the launching lug, positioning it as shown in Fig. 3 and Fig. 5. Apply glue to the root edges of the lower tip fins and place them on the lower side of the main fin directly under the upper tip fins as shown in Fig. 3. Allow to dry.

8. The landing gear may be built as a detachable display support or it may be permanently attached to the rocket. For detachable gear, cut a 1" by 5/8" piece from a scrap of BT-50 and glue the landing gear to the centerline of the piece as shown. Cut two 1" by 5/16" pieces and glue them to the edges of the larger piece (see Fig. 6A). For permanent landing gear, cut two pieces 1" by 5/16" from scrap BT-50 for the landing gear well covers. Glue them to the body guide lines drawn 5/16" to each side of (and parallel to) the bottom centerline. The front edge of the covers should be 1-1/2" from the front edge of the body tube. Glue the landing gear unit in place with the rear of the strut positioned 1/8" forward from the rear edge of the covers and straddling the bottom centerline. Stand this assembly aside to dry.

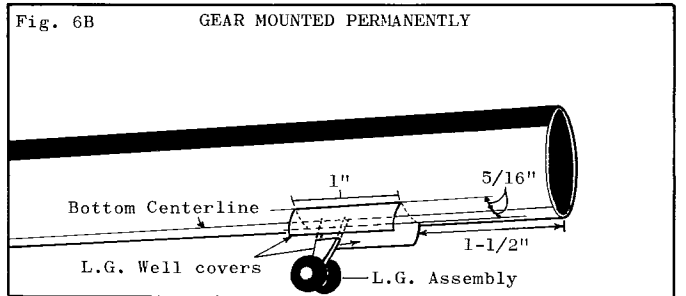
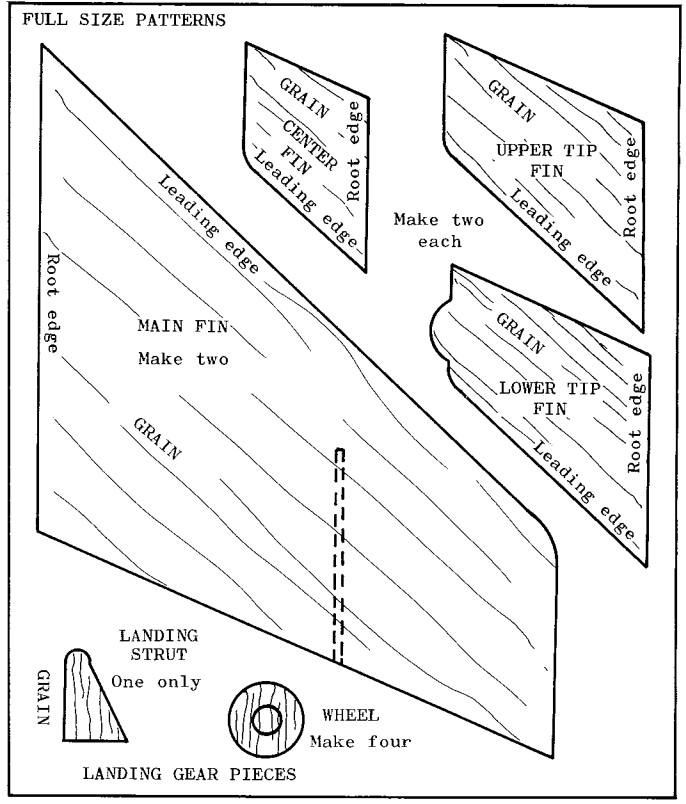
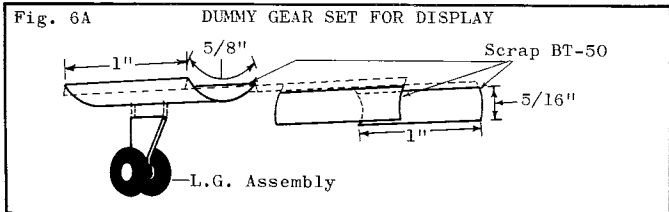

9. Assemble the parachute following the instructions that are included in the kit. Tie the shroud lines to the screw eye. Tie one end of the shock cord to the screw eye and make a small loop on the free end of the shock cord. Tie a 14" piece of shroudline to the loop, centering this piece so 7" of line is on each side of the loop. Drill a small hole on each main fin at the root edge 1-1/4" back from the leading edge and attach the ends of the line to the holes. The entire recovery system is shown in Fig. 7.

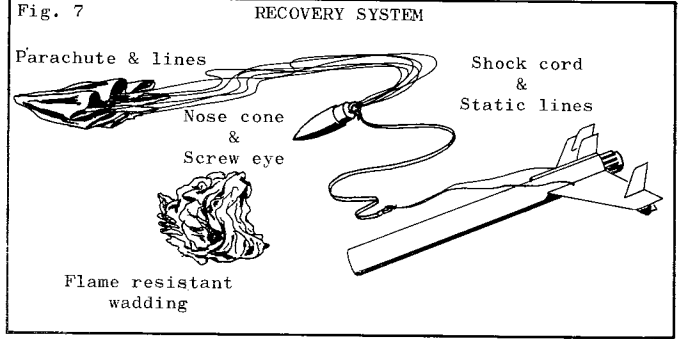

10. Prepare the COMMUTER for flight in the usual way. Insert wadding, parachute, shroud lines and shock cord into the forward end of the body tube. Gather the static lines so they meet at the forward edge of the body tube on top, and push the nose cone into place. The COMMUTER flies well with any Series I single stage engine.

**REMEMBER... LAUNCH VERTICALLY!**

# Estes Industries Rocket Plan No. 31

## the... COMMUTER

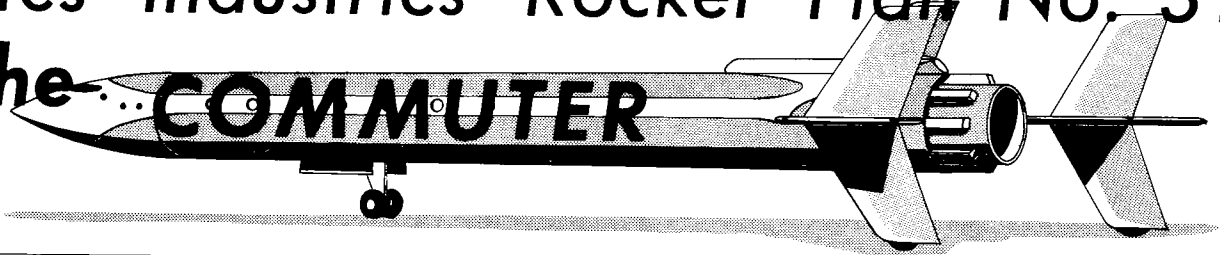

Published as a service to its customers by Estes Industries, Inc., Box 227, Penrose Colorado ©Estes Industries, Inc. 1965

### PARTS LIST

PART NAME	PART NO.
1 Balsa Nose Cone	BNC-50K
1 Main Body Tube	BT-50H
1 2050 Engine Mount	EH-2050
1 Launching Lug	LL-1B
1 Balsa Fin Stock	BFS-20
1 12" Parachute Kit	PK-12
1 Shock Cord	SC-1
1 Screw Eye	SE-1

#### MISCELLANEOUS

- 1 Scrap piece of BT-50 tube
- 1 12" x 3/32" Sq. strip balsa (or cut two square strips from a sheet of BFS-50)

#### NOTICE

Except for appearance the COMMUTER is a normal VERTICAL takeoff, parachute recovered model rocket.

LAUNCH VERTICALLY ONLY!

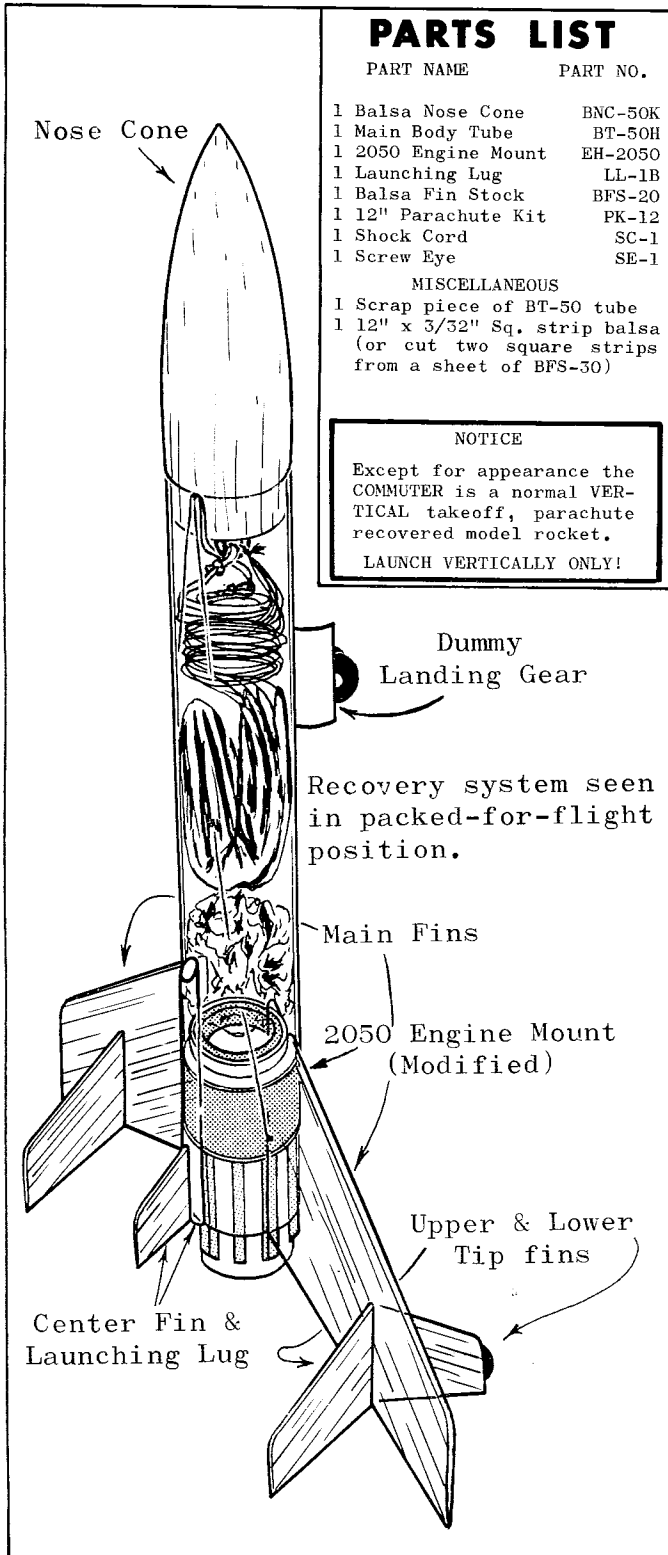

Looking into a slightly cracked watch crystal, here is what we see as one possibility for future short haul(?) air travel. The COMMUTER would admirably serve those who, for instance, had a job in New York but liked to live in Calif. One would board the COMMUTER in L.A. at 5:30 PST and land in New York at 9:AM EST...Going home after 5:PM EST would have you home in L.A. in time for a 3:PM golf date. Crazy man!

### ASSEMBLY STEPS

1. Put glue on both edges of the stage coupler and position the spacer rings. Wipe off excess glue and allow to dry.

2. Trace the fin and landing gear pieces onto a sheet of BFS-20 or onto a sheet of paper. If you trace directly on the balsa be sure to position the patterns so the wood will match the grain shown on the pattern.

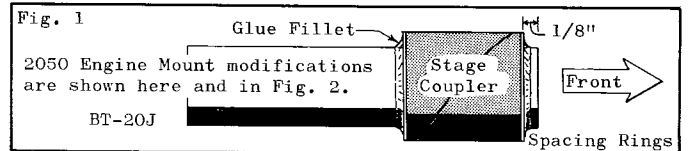

3. Slide the engine holder tube (BT-20J) through the ring-coupler assembly until it sticks out 1/8" on one side (see Fig. 1). Run a glue fillet around both ring-body joints. While the glue sets cut 8 pieces of 3/32" square balsa strips 1-3/8" long and sand one end to a slight taper as shown in Fig. 2. Glue the strips to the rear portion of the engine holder tube spacing them as shown in the Fig. 2 end view. Set this assembly aside to dry completely.

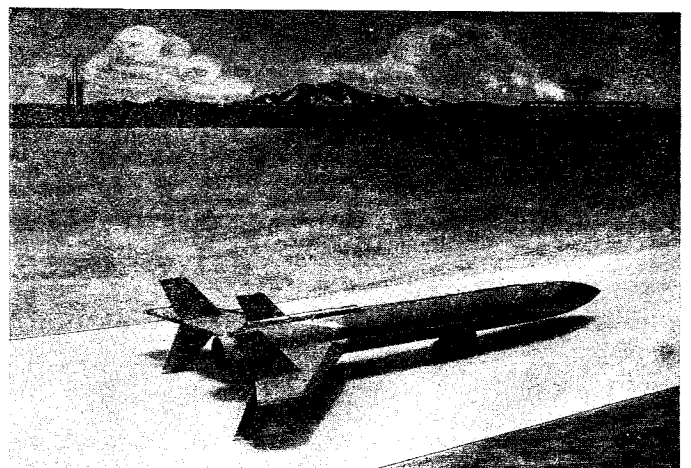
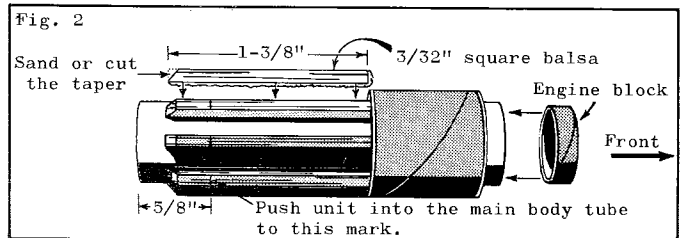

# Estes Industries Rocket Plan No. 32

Semi-Scale Model  
of the  
U.S.A.F.'s AF6

# Aerobee 44i

Published as a service to its customers by Estes Industries, Inc., Box 227, Penrose, Colorado. © Estes Industries 1965

Fig. 1

### PARTS LIST

1	8.4" Body Tube	BT-40
1	2040 Engine Mount	EH-2040
1	Plastic Nose Cone	PXC-40G
1	Balsa Fin Stock	BFS-20
1	Launching Lug	LL-1A
1	Shock Cord	SC-1
1	12" Parachute Kit	PK-12

**FAIRING PATTERN**  
(make 6)

**FIN PATTERN**  
(make 5)

Close up of tie-ons to nose cone plug

Shock cord & Shroud-lines go here

Parachute area

Wadding area

Engine Mount

2040 Engine Mount Assembly  
Spread glue 1/4" inside tube end

Push EB-20A flush with tube end

Labels: Front, Root edge, Leading edge, Grain direction, Pin Seat, Root edge

## CONSTRUCTION

- Assemble the 2040 engine mount and set it aside to dry.
- Cut an 8.4" piece of BT-40. Mark it for 5 fin positions and draw 5 guide lines from front to rear of the tube for later use in placing the fuel tube and cable fairings.
- Install the engine mount so the rear of the mount is flush with the rear of the body tube. Allow to dry.

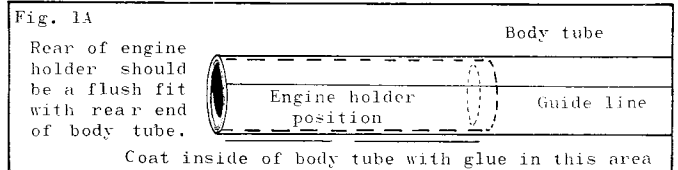

- Cut out the fin pattern and fairing pattern and lay them on the balsa fin stock according to the grain direction shown on each. Make 6 fairing pieces and 5 fins. Glue a pair of

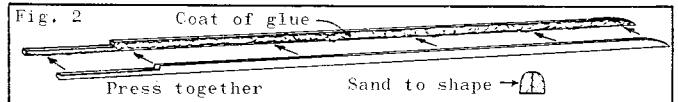

fairing pieces together as shown. Do the same with the two other pairs and set aside to dry. Sand all but the root of the fins to a rounded shape.

- Glue the fairings to the body tube along the guide lines made in step 2. Glue the fins in place on the rear of the fairings.

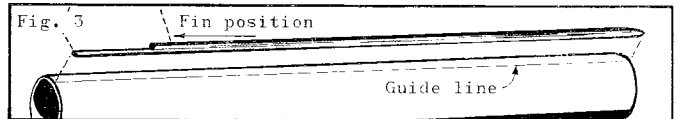

- Install the shock cord as shown in Fig. 4A. Cut two 3/8" pieces of launching lug. Glue one of them directly over the shock cord installation. Glue the other one 1/8" from the rear of the body tube in a straight line with the first one. See fig. 4B.

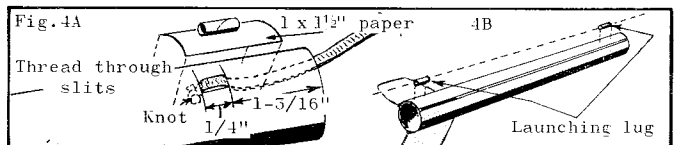

- Assemble the parachute and tie the shroud lines to the red plastic loop in the bottom of the nose cone. The free end of the shock cord is to be tied to this loop also.

## FINISHING

The color scheme of this bird is white, silver and black as shown in fig. 5. Enamel paint is recommended for a good

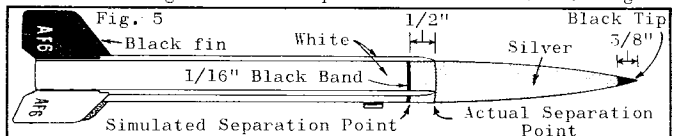

finish. Special care must be taken in painting the vinyl nose cone. Sand the surface completely with fine or extra-fine paper, to obtain a clean surface. Apply a light coat of quick drying spray enamel and allow this to dry thoroughly. Brush or spray on the regular enamel finish. Set the nose cone aside to dry at least overnight.



# R & D Contest

Do you have a real good new concept for model rocketry? An instrument for use in a model rocket? Or do you think you could develop one? This contest is open to anything new and different in model rocketry. To win, though, it must be something that is truly new and different. Your entry might be a completely new rocket design, a new or better recovery system, launching system, instrument or anything else that appears to be of value. Entries will be judged on originality, practicality, apparent value, completeness of information, neatness, etc.

- 1st Prize--\$50 in merchandise credit.
- 2nd Prize--\$25 in merchandise credit.
- 3rd Prize--\$10 in merchandise credit.
- 4th Prize -- \$5 in merchandise credit.
- 5th through 10th Prizes--Astron X-Ray Kits.

- 1) All plans must be drawn to scale. Ink drawings are recommended, pencil drawings are acceptable.
- 2) A parts list must accompany entry.
- 3) All entries must have been built and tested. Those considered in the final selection of winners may be requested to supply photographs of the project to the judges.
- 4) A chronological list and description of tests on the entry must accompany it.
- 5) Sufficient information must accompany entry to allow judges to build an exact duplicate of the original model or system.
- 6) The decision of the judges is final.
- 7) Entries must be postmarked no later than midnight, June 30, 1965
- 8) All entries become the property of Estes Industries, Inc. No material will be returned.

000000000

## Enter Now! ESTES SCIENCE FAIR!

Did you use model rocketry in a science fair project this year? If so, we've got a special contest for you. To enter, just send photos of your exhibit, a general description of the project and a copy of your report to: Science Fair Contest, Box 227, Penrose, Colorado, 81240. If your project is picked as one of the best by the judges, you can win one of these great prizes.

- 1st Prize--\$50 in merchandise credit.
- 2nd Prize--\$25 in merchandise credit.
- 3rd Prize--\$10 in merchandise credit.
- 4th Prize -- \$5 in merchandise credit.

### — CONTEST RULES —

- 1) Each entry must include a photo of the exhibit as used in the actual science fair, a general description of the nature and extent of the project, a copy of the report used in the project and a statement signed by your teacher or parent certifying that the entry depicts the project as it actually was entered in the fair.
- 2) Entries must be postmarked no later than June 30, 1965.
- 3) Employees of Estes Industries and members of their immediate families are not eligible to enter this contest.
- 4) The decision of the judges is final.
- 5) All entries become the property of Estes Industries, Inc. No material will be returned.

NOTE: Prizes previously won by the project will not be considered in judging entries. However, the Editor would appreciate it if you would include such information.

# Society Revises Safety Code

The Astron Rocket Society recently announced a new edition of their safety code. This revised version was prepared after an extensive study of model rocketry practices. The main goal of the society in preparing the changes was to establish more complete guidelines for maintaining safe practices in model rocketry.

According to most experts in the field, a good share of the credit for the safety record of model rocketry belongs to the rocketeers themselves, who have carefully followed an approved safety code. This new edition of the Astron Rocket Society Safety Code is presented here in the hope that rocketeers will take note of its provisions and conduct their activities accordingly, thus helping to make model rocketry even safer.

## ASTRON ROCKET SOCIETY

### SAFETY CODE

As a model rocketeer I will act in a mature manner with safety foremost in my mind in all my model rocket activities and will obey this safety code at all times.

- 1) I will not attempt to compound propellants or other combustible chemicals or tamper with pre-manufactured rocket engines. I will not use model rocket engines for purposes other than those for which they are recommended by the manufacturer. I will inspect each rocket engine before use and never use an engine which shows signs of physical damage, remembering that any rocket propellant can be explosive under certain conditions.
- 2) I will not smoke near rocket engines, launch my rockets in the presence of highly combustible materials, use flammable recovery wadding or engage in any activity which would present a fire hazard.
- 3) I will never use any metallic rocket engines, will not construct my model rockets with substantial metal parts in the area of the engine, and will not launch any rocket over 16 ounces in weight or containing more than 4 ounces of propellant in compliance with Federal regulations.
- 4) My model rockets will be electrically ignited, using a launch system with either a switch protector or a safety interlock to prevent accidental ignition of the rocket engine, and I will remain at least 10 feet away from any rocket which is being launched. I will use only igniters of the type recommended by the engine manufacturer.
- 5) I will launch my model rockets using a launching rail or other suitable guide means aimed within 25 degrees of the vertical to assure a safe and predictable flight path, and will launch only rockets whose stability characteristics have been predetermined.
- 6) I will not fly model rockets in high winds, conditions of low visibility, in the vicinity of low flying aircraft, near tall buildings, near people not aware of the launching, or under any conditions which might endanger property or persons.
- 7) I will not launch rockets so that their ballistic trajectory will carry them against targets on the ground, and will never use an explosive warhead or other pyrotechnic payload in a rocket.
- 8) My model rockets will contain recovery devices which will deploy at an altitude of at least 50 feet to return the rocket safely and undamaged. To insure proper operation of my rocket's recovery system I will make a careful pre-launch inspection of all the recovery components with special attention to tightness of the engine and nose cone.
- 9) To prevent accidental eye injury I will always either place the launcher so the end of the rod is above eye level or cap the end of the rod with my hand when approaching it. I will not place my head or body over the launching rod.
- 10) When conducting research activities with unproven designs or methods I will, when technically possible, determine their reliability through pre-launch static tests, and I will conduct launchings of unproven designs in complete isolation from persons not participating in the actual launching.

(Revised 1/1/65)

# THE LUNAR

Ever since his beginning, man has been curious. He seems driven to investigate any unknown thing. One object of his curiosity is the moon, the white ball in the sky that we can see almost every night. It seems so close, yet so far away.

Trips to the moon are not a new thing. As early as the year 160 A. D., a Syrian named Lucian wrote a story about a trip to the moon. Now, 1800 years later, this goal has become a real possibility. As our late President, John F. Kennedy, put it in his address to Congress, "I believe that this nation should commit itself to achieving the goal, before this decade is out, of landing a man on the moon and returning him safely to the earth. No single space project in this period will be more impressive to mankind, or more important for the long-range exploration of space. And none will be more difficult or expensive to accomplish."

The challenge is obvious. James E. Webb, Director of NASA, said, "The human race is going forward in this field. The real question is: Are we to do less than we are capable to do?" He also stated, "Scientists are convinced the next breakthrough about the universe will come from the moon."

People ask why we should go to the moon. There are many reasons. One is to answer questions that have puzzled astronomers and scientists for years. They ask "What caused the craters on the moon? What about the "seas" of the moon, are they filled with dust? Just what is the nature of the surface of the moon?"

Space scientists look upon the moon as the stepping stone to the planets. Since the gravity on the moon is much less than on earth (1/6 as great), it would be very easy for rockets to take off from the moon. One scientist has suggested a catapult system which would push rockets away from the moon with enough force to eliminate expensive boosters.

By these measures we would be able to learn the answers to questions such as the possibility of life on other planets. There is even a slim chance that we will discover life on the moon. Scientists have theorized as to the possibility of "dormant molecules" buried in the surface of the moon.

Science is a search for knowledge. Much knowledge will be gained by the moon project. Some of this will be in the fields of geology and astronomy. Astronomers will be greatly benefited by the absence of an atmosphere on the moon. They will have an unrestricted view of the planets of our solar system and beyond into the universe.

Vast amounts of knowledge are now being discovered and much more will be unveiled in the future in the field of rocketry and space flight. The fact that we are really moving ahead can be seen by the recent Saturn launching which placed in orbit a payload weighing 1000 times as much as our first satellite six years ago.

So far these reasons have been mainly of interest to the scientific, space-minded person. What about some of the other reasons for going to the moon? Prestige has been cited as one of these reasons. It is very true that if the United States is the first to land men on the moon our country will gain tremendous prestige. Not only will we be putting men on the moon first, but we will also be showing the world that we can come from behind in a race and win. There is also the great sense of security in knowing that we are not only the No. 1 world power, but also the leader in space.

(Editor's Note: Most model rocketeers are vitally interested in our nation's space program. Many hope to participate directly in the exploration of space. If such direct participation is to be possible tomorrow, the space program must have the full support of all of us today. If enough voices are raised in support of a continued and even expanded effort in space, our chances to realize our dreams will be much greater. This Writer's Program article presents some of the reasons for our space program, and is published in the hope that it will stimulate more rocketeers to express themselves clearly and publically on this subject.)

# DERBY 1965

By Leslie D. Ulm

The space program appeals to students. It strikes their imagination and thirst for adventure, stimulating them to stay in school and strive to learn more. The moon race has given them a definite goal.

Occasionally someone asks, "Why should we send a man to the moon? Can't instruments do the job?" It should be pointed out that much of NASA's program uses machines and instruments, but ultimately man will be needed as observer, repairman and judge. A comparison can also be made: The moon is, in reality, a rock. Geology is the study of rocks. Geology requires few instruments but many men. To study it properly, men are necessary on the moon.

A mountain climber says he climbs a mountain "because it is there." Dr. S. Fred Singer said, "I see its (the moon project) importance in that it's part of man's adventure in living in the universe, and I certainly think it will be done. I think enough justification will be brought forward to do it. Perhaps it should be done without justification--just because it can be done." But there is plenty of justification. Let's look at another phase of the controversy--the military aspect.

Some feel it would be rather foolish to go to the expense of sending a military missile 240,000 miles to the moon so that it could be fired back 240,000 miles to hit a target that was 5,000 miles away in the first place. But this is not the real issue. Warfare is constantly changing. One military consideration is the laser, the newly developed instrument that emits a very intense beam of light. Such a light beam has been sent to the moon. By the time it hit the moon, it had spread out only two miles. This could be turned around, greatly intensified, and become a weapon. The ray could be aimed at points on the earth with great accuracy.

We must also consider our competition with Russia. Many articles have been written as to who's ahead in the space race, and there are articles favoring both sides. Let's review the Soviet space program.

The Russians were the first to place a satellite in orbit. They were the first to place a man in orbit. Their cosmonauts have logged more hours in space than ours.

The Soviets started out with slightly more powerful rockets than we had. Due to this fact, we have been forced to develop the art of miniaturization. Many scientists now feel that this is one thing that the Russians badly need to reach the moon.

# PROJECT APOLLO

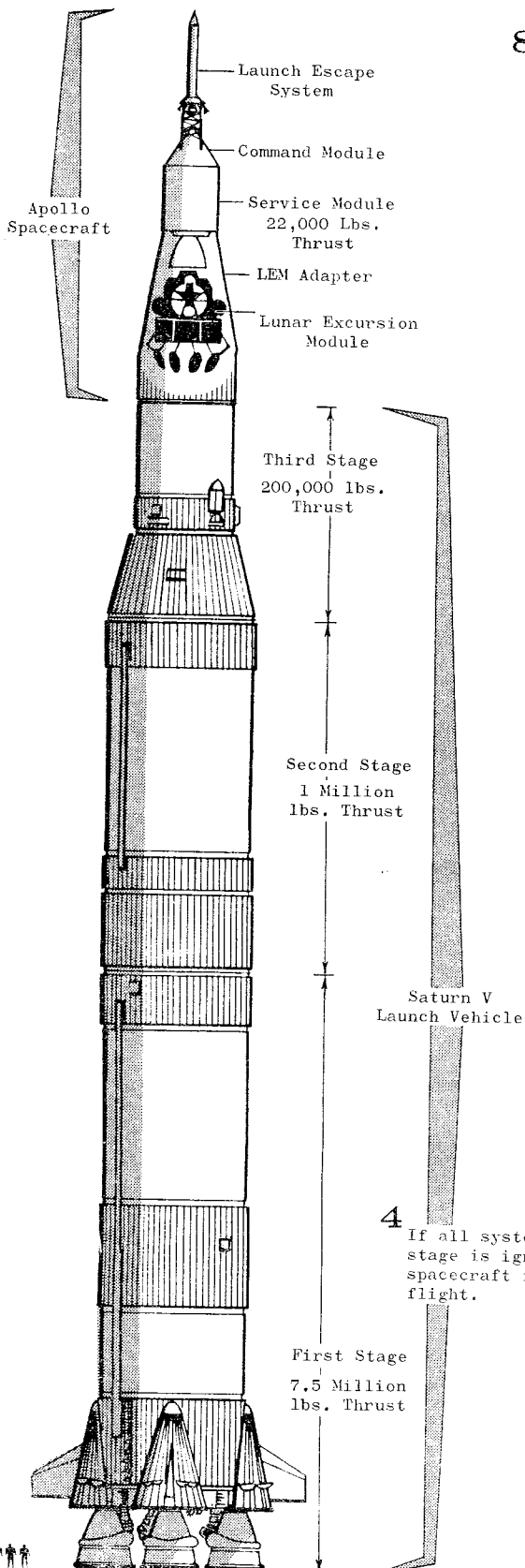

8 After 24 hrs. LEM takes off for rendezvous with C/M. The astronauts leave LEM which is then left in lunar orbit

6 Service Module engine retro-fires to place the spacecraft into lunar orbit.

9 S/M engine ignites for 2-1/2 minutes increasing speed by 2000 M.P.H., breaking lunar orbit and heading for home.

7 2 astronauts enter LEM and separate from the C/M. LEM's landing engine fires to set approach orbit, refiring to slow LEM to hover. LEM then settles in at about 7 M.P.H. The command module continues in lunar parking orbit.

5 Apollo spacecraft separates from 3rd stage; docks with LEM and in turn separates LEM from 3rd stage which is then abandoned.

2 2nd. stage separation and insertion into orbit

3 1-1/2 orbits for systems checkout

1 1st. stage separation

4 If all systems "GO", 3rd stage is ignited sending spacecraft into cislunar flight.

10 After exact re-entry course is established, S/M is discarded.

11 C/M is turned to put heat shield forward for re-entry.

12 Aerodynamic deceleration slows craft to about 650 M.P.H. The drogue 'chutes deploy 5 main 'chutes for a gentle landing in the desert southwest.

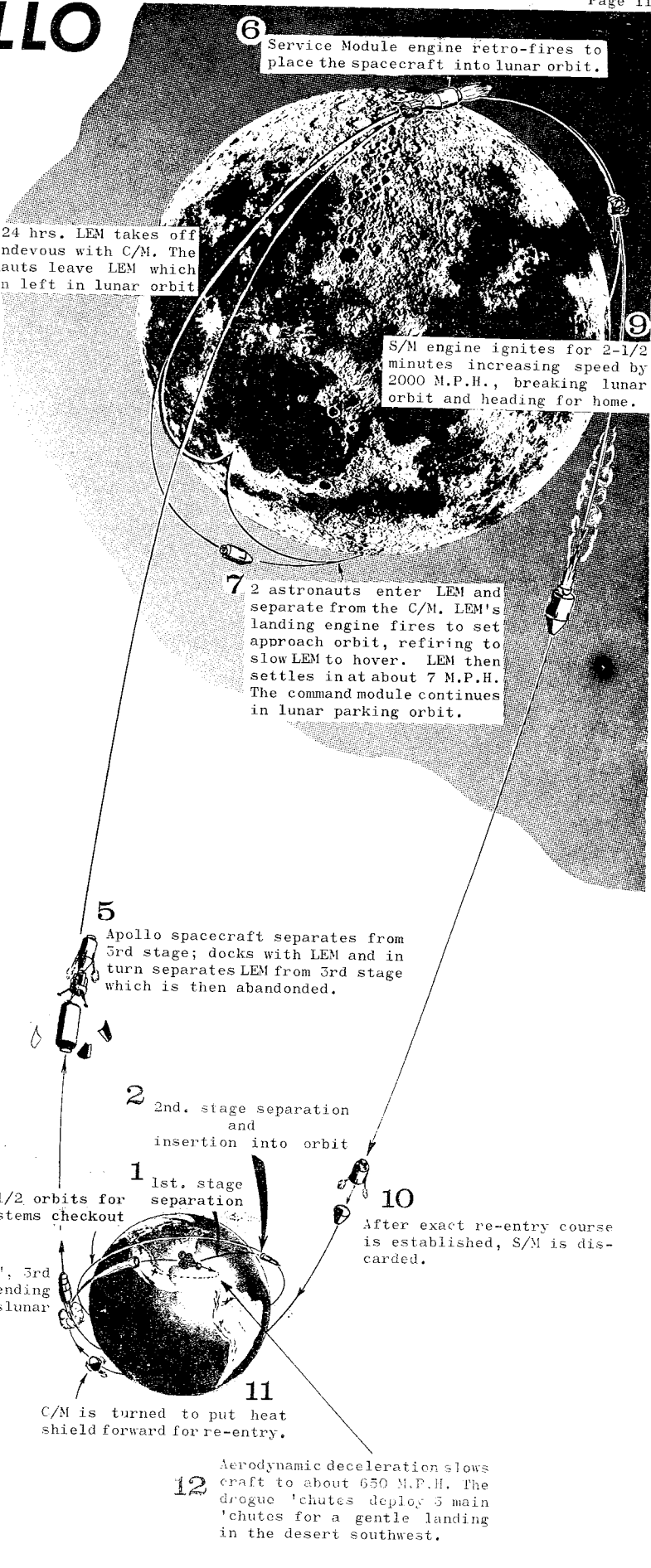

Actually, it is hard to say much that is definite about the Soviet space program because of their secrecy, but we do know that there is a close race going on. According to Dr. Hugh L. Dryden, "... when we started planning to go to the moon we needed to build bigger rockets, but so did the Russians. So, in one sense, we started fairly even."

Some persons have dug into the Russians' actual motives for going to the moon and have come up with some interesting findings. Their motives appear to be strongly military. After Titov's flight, Khrushchev said, "We placed Gagarin and Titov in space, and we can replace them with bombs that can be diverted to any place on earth." Marshal Malinovsky stated, possibly with space in mind, that "New scientific ideas and technical inventions, as a rule, are evaluated not only from the standpoint of their general importance, but also from the standpoint of the prospects for military use."

The military aspect of the moon race should not be over-emphasized, however. It is quite likely that the possibilities for peaceful cooperation in space are greater than any military possibilities. Exchange of information and sharing of experience offer a means for nations to grow closer together.

Some people use the "Columbus Theory" as a reason for our exploration of the moon. This theory compares Columbus's planned voyage around the world with our attempt to reach the moon. Columbus discovered a whole new "world." Who knows what completely unexpected discoveries we may make?

As we can see, there are reasons for going. It might be well at this point to evaluate some of this. What happens before we get to the moon? For one thing, research is greatly stimulated. Moreover, we now have a worldwide tracking and communications network, weather satellites and navigation satellites, all brought about in whole or in part through our moon program.

After we get to the moon, lunar colonies may be established. Scientists who have studied the subject tell us that all the elements necessary for life are present on the moon. The colony would probably be underground because the surface of the moon is subject to temperature extremes ranging from over 200° F in the day to 200° F below zero at night. However, most research activities would be carried out on the surface. Atmosphere is practically non-existent, but this lack will be an advantage. The astronomical aspect has been considered. Electronic experiments using vacuum tubes of unparalleled size will be possible. Development of propulsion devices to operate in cislunar, interplanetary and even interstellar space will profit from the low gravity and vacuum conditions.

Now that we've looked at some of the specific reasons for going to the moon, let's turn our attention to the program itself and some of the problems involved in getting to the moon.

From time to time, schedules of space events have been published in magazines. Since our space effort is dedicated to reaching the moon before 1970, the schedules so indicate. But a comparison of some of the schedules published a few years ago and our actual progress to this point shows that we are behind our own schedule. It seems that our program is always being postponed. If this trend continues it seems hardly probable that we can reach the moon by 1970. But it still is possible to meet our deadline.

Shortly after the first Sputnik was fired into orbit, the National Aeronautics and Space Administration was organized to coordinate our space activities. They set up a three-fold plan for putting men on the moon. The steps in the plan were Project Mercury, Project Gemini and Project Apollo.

Before we land men on the moon, many preliminary steps have to be taken. One of the foremost preliminary moon projects supplementing the main program is the Ranger program designed to obtain close-up pictures of the moon's surface. After six failures in this program, Ranger 7 made a successful flight in July, 1964. The moon probe sent back over 4,000 pictures which were termed "1,000 times better" than any previous

moon photos. Another unmanned moon project is Project Surveyor, whose object is to land on the moon and send back information from the surface.

The purpose of Project Mercury was to put men into space, both in suborbital flights (up and down) and orbital flights around the earth. This program was successfully completed with Gordon Cooper's flight of 22 orbits in May, 1963.

Efforts have now been turned toward the Gemini program. A number of shots are planned in this phase of our moon project. The big difference in this program is that two astronauts will be in the space capsule. The main purposes of the program are to study the effects of prolonged space flight and to rendezvous a manned Gemini capsule with an unmanned Agena spacecraft, thus developing knowledge and skills needed for Project Apollo.

Project Apollo, which follows Project Gemini, is the apex of our present lunar program. The project consists of more orbital flights to test the capsule and further develop necessary skills and techniques, followed, in 1969, by the supreme flight. A huge Saturn V will send the Apollo spacecraft with the three astronauts toward the moon. The Apollo craft will orbit the moon at a distance of about 80 miles. Two of the astronauts will then transfer to the Lunar Excursion Module (nicknamed LEM) to land on the moon. After exploring the moon the two astronauts will return to the orbiting Apollo craft and the capsule will return to earth. It is interesting to note that we have had five straight successes with the Saturn rocket. Recently it succeeded in lofting the heaviest payload ever put into orbit by the United States or Russia.

Those are the elements of the program. It will cost money--between 20 and 40 billion dollars. This breaks down to a cost of over \$25 per year for each person in this country for the next six years. But this is less than what we spend on chewing gum and cigarettes. Further, this money will be spent here on earth and not on the moon. About 90% of it is spent outside of NASA, and almost all of it changes hands many times, which actually helps to strengthen our economy.

Employment has already been affected. Over 435,000 men and women (Ph.D.'s, engineers, machinists, technicians and clerks) are working on our space effort in NASA and private firms. There are approximately 20,000 firms involved.

Even so, there is rising opposition to this cost. NASA warned Congress not to start this program unless they intended to carry it through. Three years ago there were no complaints by Congress and they happily passed the budget for the space program. The next year this was willingly doubled. But now that some of the glamour has worn off, some persons are balking.

Often we hear people say that we should spend this money on cancer research or education. Wernher von Braun points out that even if this money is not used for space research, it probably would not be used for cancer research. President Johnson reached the heart of the problem when he said, "In fact, it is more likely that the funds released thereby (by cutting spending on space) will go to the race tracks or for larger yachts, or for fancier country clubs. Do not be misled by the argument that space is taking from other essentials. Incidentally, most of those who make that argument would also oppose using the funds to meet the other essential requirements of our burgeoning society." Actually, we have increased our spending on education and medical research. The National Defense Education Act passed in 1958 was a direct result of the first Sputnik.

So that's the story. The race to the moon is an expensive project. Why should we go? There are many reasons. Many responsible individuals feel that we can't afford not to go. The possible gains from the program are beyond imagination. Although the moon is a barren, airless wasteland, it may become one of our most valuable assets.