

Volume 8, No.1
August, 1968

MODEL CORNER

NEWS





Do you have a question about model rocketry that has you stumped? In spite of your research work you can't seem to find an answer? If this is your problem, Estes Industries has a department to help you. It's called *Rocketeer Mail*.



The Rocketeer Mail department at Estes Industries is dedicated to the task of answering all questions about model rocketry. The people in this department don't claim to have all the answers and aren't afraid to say so, but you can bet they'll do their very best to help you in your search for more knowledge.

Every rocketeer receives a personal answer. While some letters can be handled with a short explanation, others require more time, research and detail. Often rocketeers come up with highly technical questions, some of which require the department to call upon experts for help. Rocketeer Mail then turns to our research and development people, to other departments which might have specialized information – or they grab a book from their extensive reference library to answer the question,



The department is headed by Arlene Wheeler, supervisor. An avid rocketeer, Mrs. Wheeler has been answering rocketeers' questions for several years.

At one time she took care of the letters by herself. However, there are so many people interested in knowing more about model rocketry that she now needs several helpers. According to Mrs. Wheeler the department receives letters from about 100 rocketeers every day.

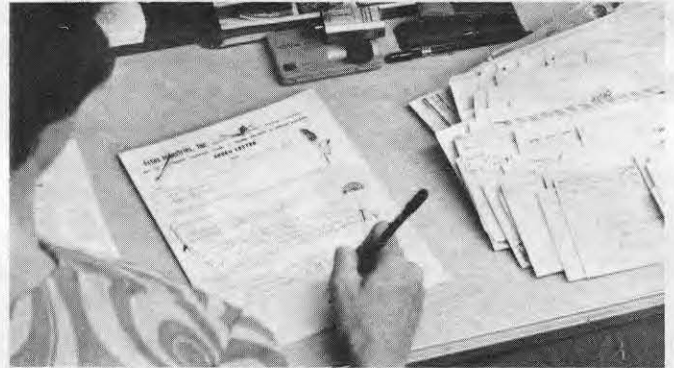

Letters come in from all kinds of rocketeers – beginners, experienced modelers, a few very young rocket enthusiasts, advanced college students, and even a number of grandfathers. Some questions are simple while others are quite complicated. It doesn't matter how insignificant or how difficult the question may seem, nor who may be inquiring about model rocketry. The Rocketeer Mail department will try to find an answer or give guidance to where the answer might be found.

Occasionally a rocketeer does come up with a question no one at Estes can answer. Sometimes he can be referred to other technical experts for a solution. Other times, however, his question is so unique that it's doubtful that *anyone* knows the answer. The only suggestion possible in that case is that he start his own research program and answer this question for all rocketeers.

Many requests come in for information about the United States space program. While model rocketry is based on the space program and we maintain an extensive library of information on NASA vehicles and programs, we do not have that much inside "dope" about it. Instead we usually try to refer a person to the correct agency or office.

Still another task of Rocketeer Mail is keeping a record of questions and comments. This information goes to other departments so steps can be taken to improve Estes Industries' products, literature and service.

Next time you have a question about model rocketry and can't find the answer, why not sit down and write us a letter? Rocketeer Mail will be glad to help you.

MODEL ROCKET NEWS

© Estes Industries, 1968

The Model Rocket News is published by Estes Industries, Inc., Penrose, Colorado. It is distributed free of charge to all the company's mail order customers from whom a substantial order has been received within a period of one year. The Model Rocket News is distributed for the purpose of advertising and promoting a safe form of youth rocketry and for informing customers of new products and services available from Estes Industries.

Vernon Estes
Publisher

Gene Street
Chief Illustrator

William Simon
Editor

NEW DESIGN CONTEST

ANYONE
CAN ENTER

Big \$50.00
Merchandise
Award!
Plus
Special
MERIT
Awards



A CONTINUING CONTEST . . .

SEND AS MANY ENTRIES AS YOU LIKE!

Do you enjoy designing new types of models (altitude, payload, duration, boost-glide, etc.) or support equipment such as launchers, telemetry devices and the like? Wouldn't you enjoy it even more if you knew your work had a chance of winning an award for you? In that case, the Estes Design of the Month Award competition is perfect for you.

In response to thousands of requests and in keeping with the Estes policy of encouraging and promoting education through model rocketry, arrangements have been made to offer a Design of the Month award.

All plans which reach Estes' offices during the calendar month will be considered for the award of that month. Each month the designer of the winning entry will receive a certificate entitling him to \$50.00 in merchandise and an award certificate suitable for framing. When your entry is received we will send an acknowledgment. However, we will not be able to enter into any other correspondence concerning your entry.

There aren't many rules, and they aren't hard to follow. A few tips, however, may help you in preparing your entry. Designs should be new, original and different — but they also need to be workable. The goal is to develop something new that other rocketeers can build and use successfully, too. If you're not sure your design will work, then put the extra effort into it that it takes to *make* it work. This way you gain the additional engineering experience and you also have a better chance to win.

Entries will be judged on practicality, originality, neatness, completeness and clarity. Plans do not *have* to be flight tested and proven; however, a proven design is more apt to win. Launching and other accessory items will also receive extra points if they have been field tested and the test results noted with the entry. Photos

are not required, but pictures of your completed design will be appreciated.

— CONTEST RULES —

1. All entries become the property of Estes Industries; none can be returned.
2. Employees of Estes Industries and members of their immediate families are not eligible to enter.
3. Designs should be sent to the Design of the Month Editor, Estes Industries, Inc., Box 227, Penrose, Colorado 81240. However, all plans sent to us which are not specifically addressed to another contest or department will be automatically placed in the Design of the Month competition.
4. Any type of model rocketry design can be entered (rockets, boost-gliders, launching or recovery devices, etc.).
5. All designs reaching Estes Industries during the calendar month will be entered in that month's competition. (Date of receipt — not postmark — will determine the month in which a design will be judged.)
6. If two or more exceptional entries are received during any month, the judges may, at their discretion, make identical first-place awards or give additional special merit awards.

Award winners will be notified by mail. The name of the winner of each award will then be announced in the next issue of the Model Rocket News.

Spring Conventions Growing Model Rocketry Feature

March, 1968 saw the spring-time model rocket convention come of age as the Steel City Section of the NAR held its third annual convention and the Massachusetts Institute of Technology Model Rocket Society sponsored their first convention.

The first of these, held in Pittsburgh at the Shady Side Academy, is now a familiar, well-established institution. Even so, this year's meeting drew a record attendance of 200 as rocketeers gathered from throughout the Eastern states. Discussion topics ranged from clubs to research projects as rocketeers set out to find ways to improve their hobby.

The MIT convention, held at the school's campus in Cambridge, Massachusetts, focused more on the technical aspects of model rocketry. Among the featured activities were the presentation of technical papers and a demonstration of computer simulation of model rocket flight.

Both conventions indicated the growth in technical ability among model rocketeers. Sponsors of both conventions predict an even greater interest in the future as well as additional meetings in other areas across the country.

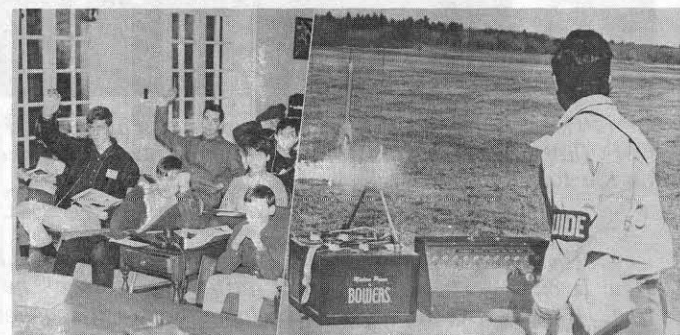

LEFT: Construction techniques discussion group held an active session at Pittsburgh. RIGHT: Gordon Mandell launches Big Bertha during MIT convention flight session at Hanscom Field. MITMRS Photo.

NOTES FROM THE BOSS



The Scene: A second-floor room at the Estes plant, otherwise known as the President's office. Bill Simon and Gene Street are sneaking by on their way to the coffee pot for something to wake them up.

"Guess what, fellows!"

"What's that, Vern?"

"It's time to judge the Single Stage Design Contest. Bill, if you'll round up Wayne Kellner and Bill See, Gene and I'll pick up the entries from Arlene and we'll get right on it. Shouldn't take more than a couple of hours to finish judging."

(2 hours later)

"Hey Vern, you said this would only take a couple of hours. It's 10:30 already and we're still on the first box. At this rate it'll take all day to get through the other three boxes."

"Yeah, how's about stopping for coffee?"

"Hey, wait a moment - take a look at this one! He must be a professional artist the way he drew these plans. Let's see - he's got the plans, instructions, parts list . . . I don't see any photo . . . Oh! Here, he says 'Sorry I couldn't send a picture. I didn't think to take a picture before it was launched. It must have gone into orbit. It's probably the best rocket I ever built.'"

"It sure is a good design, Wayne. It's too bad we have to put his entry in the 'rejects'. The rules say to send a picture, and we can't make any exceptions - it wouldn't be fair to the rest."



"Here, Gene, try this one for size. It's a real doozy. Only thing is he put big fins on the nose and little ones on the tail."

"Did he flight test it, Vern?"

"Hmm. Let's see. Oh! Here it is - he says he flew it only once and it wasn't quite as stable as he'd like. However, it did make three loops before it crashed. That's a lot better than the other design. It only made one loop before it hit."

3 hours later

"How 'bout this one, Bill. Look at the way the fins sweep back and then forward to the pods. It looks like it's going supersonic just sitting there. I'll bet this fellow's going to be a top industrial design artist some day."

3 more hours

"Gaaaaah!"

"You get stiff from sitting on the floor, too?"

"At least we're through them all once. It should go faster tomorrow when we start the final selections from these 82 runner-ups."

So that's the way the judging went. The second half proved to be about as hectic and just as much fun as the first. There were a lot of top designs, making it very difficult to decide which ones to pick.

Thanks to all of you who entered the contest. Rocketeers like you who work on developing improved designs are going to keep this hobby progressing just as fast as our space program (if not faster).

Vern



CAPE ESTES, COLO., JULY 30: "If it can be done - Estes can do it better." That's the motto we have here at the plant and the picture's proof. One thing we can't do better, though, is take them down. Wind, weather or the power company will have to do that because we don't want to get killed. If you value your life more than your model, you'll leave yours on the lines, too. To save a lot of grief, launch model rockets away from power lines.

CAREER OPPORTUNITIES

Do you have skills in engineering, art, writing - or any other field connected with model rocketry? Would you enjoy a permanent, challenging and rewarding career with the world's foremost model rocket manufacturer?

Estes Industries has employment opportunities for mature individuals in a wide variety of positions. If you feel you have the skills or training which could contribute to the growth of model rocketry - if you want to help meet the needs of tomorrow's scientists and engineers - let's talk about it.

Anyone interested in a position should contact us by mail. For more information and to apply, write to:

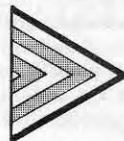

Personnel Dept.
Estes Industries, Inc.
Box 227
Penrose, Colorado 81240

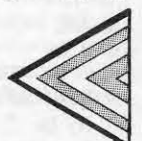

A brief mention of your interests and background with the initial correspondence would be helpful.

Tape makes Quick Stand-off

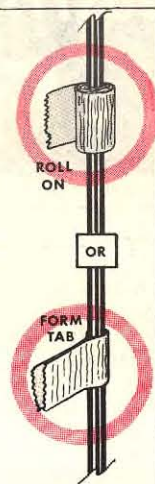

A strip of masking tape is a good temporary stop to hold your rocket up off the blast deflector to prevent clip shorting. Just apply a strip of tape to the rod at the point where the bottom end of the launching lug reaches when the bird is held at the proper working height above the deflector.

Pat Kilroy of Detroit, Michigan suggested this idea.

Use Launch Rod to Align Two or More Lugs

William S. Christopher of Mundelein, Illinois recommends that, when installing two or more launch lugs, you put a length of launch rod through them while the glue is still wet and align as needed to eliminate binding, etc.

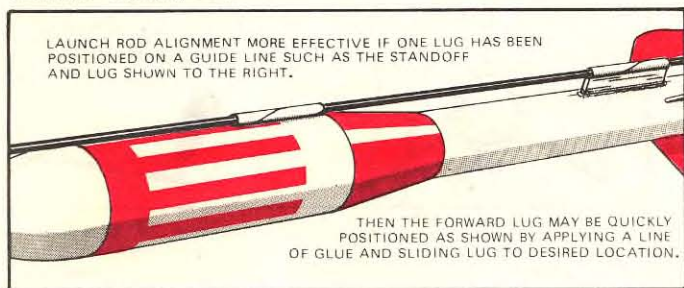

Needle Threader Handy for Model Maker too!

Daniel Auth of Pittsburgh, Pennsylvania suggests the use of a threader like that shown to ease the threading of shroud lines through the eye

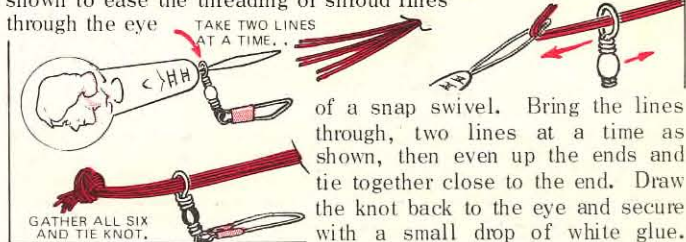

of a snap swivel. Bring the lines through, two lines at a time as shown, then even up the ends and tie together close to the end. Draw the knot back to the eye and secure with a small drop of white glue.

Pencil Compass & Knife make Ring Cutter

For cutting special size adapter rings, Bill See of Coal Creek, Colorado suggests replacing the pencil in a pencil compass with a model knife (KNS-1). The ring can be positioned and cut out in the same operation. Set the compass for the larger radius first, then cut the inner radius. It may be necessary to wrap a few layers of masking tape on the knife handle to make it fit.



If your bird develops fin-sag during construction or after a repair, heat the white glue joint over a 60 to 100 watt lamp for about 45 seconds, then gently straighten the fin and hold it in place as the joint cools.



Tape on a Shock Cord

A strip of masking tape, cut to 1/4" width, when applied as shown, will securely attach the shock cord to the screw eye. This idea was sent in by Michael Zaritski, Jr. of Aliquippa, Pennsylvania.

(A pair of tape strips works well for this method of attachment but be sure to secure the end of the second strip with a spot of white glue to prevent eventual unwrapping.)

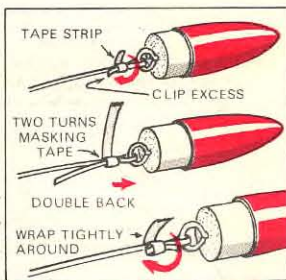

PAINT CORNER



Jimmie Longuillo of Rochester, New York brushes some thinner around the edge of a paint bottle cap that's hard to get open. More than one application may be necessary before the cap turns freely.

Tom Morris, of Littlefork, Minn. suggests using a 3" piece of plastic straw as protector for a paint brush if you should have to leave your work for a short time.



Estes Industries Rocket Plan No. 53

Aero -Fin

A Fine Sports Flyer

Designed by GARY LINDGREN
of West Covina, California

Published as a service to its customers by Estes Industries, Inc., Box 227, Penrose, Colorado 81240 © ESTES INDUSTRIES, 1968

PARTS LIST

- 1 Body Tube - Part #BT-30
- 1 Nose Cone - Part #BNC-30N
- 1 Sheet Balsa Fin Stock - Part #BFS-30
- 1 Engine Block - Part #EB-30A
- 1 Launching Lug - Part #LL-2A
- 1 12" Parachute Kit - Part #PK-12
- 1 Shock Cord - Part #SC-1
- 1 Screw Eye - Part #SE-1

Tools and supplies you will need in addition to these parts are scissors, a model knife, white glue, sandpaper, sanding sealer and paint or dope in the colors of your choice.

Building the AERO-FIN

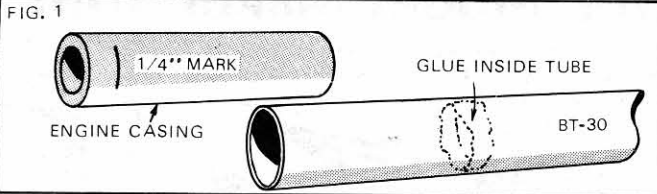

1.) To install the engine block, first mark an expended engine casing 1/4" from one end. Put a dab of white glue near the tip of your little finger and, reaching into the tube as far as you can, spread the glue around the inside of the tube.

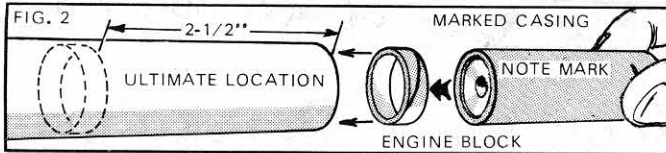

2.) Fit the engine block into the end of the tube. Use the marked engine casing (holding it by the 1/4" end) to push the engine block into the tube until the mark is even with the rear of the tube. Do not stop or the glue may set with the block in the wrong place. Withdraw the engine casing immediately.

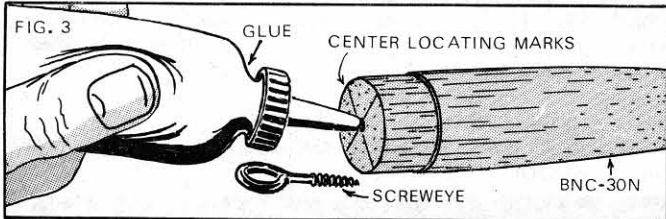

3.) Locate the center of the base of the nose cone and turn the screw eye into place. Remove it and squirt white glue into the hole. Replace the screw eye and wipe off any excess glue.



4.) Trace the fin patterns, shock cord anchor and marking guide onto stiff paper and cut them out. Wrap the guide around the rear end of the tube (the end with the engine block) and mark the tube at each arrow point. Draw a connecting line between each pair of marks. (The lines should be parallel to the tube centerline.)

5.) Lay out 3 each of the main fin pattern and the tip plate pattern on the BFS-30 (be sure the tip plate centering marks are placed on the balsa tip plates.) Carefully cut out all the balsa parts and sand them to a symmetrical airfoil shape.

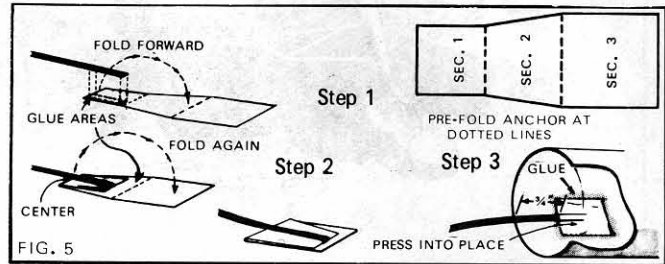

6.) Prefold the shock cord anchor on the dotted lines, then flatten it out. Spread glue over section 1. Lay one end of the shock cord in place and fold section 1 over. Spread a thin layer of glue over the back of section 1 and the exposed parts of section 2 and fold again. Clamp the unit together with fingers until the glue sets. Spread a thin layer of glue about 3/4" in from the front end of the body tube (about the size of the anchor) and press the anchor onto the glue. Hold the anchor in place until the glue has set.

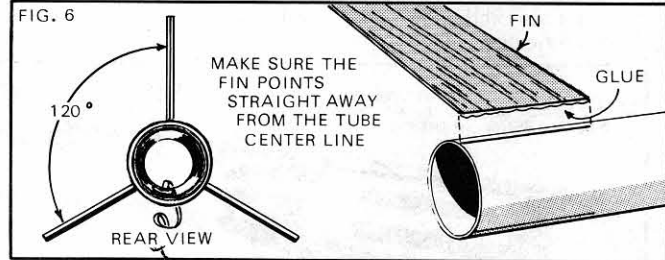

7.) Spread glue on the root edge of one of the main fin pieces and position it on one of the guide lines. The fin should stick straight away from the body tube as seen in the rear view. Repeat this step with the other two main fin pieces. Stand the bird on its nose while the main fins are drying.



8.) Trim the parachute on its edge lines. Make sure the chute material is spread out printed-side up, then cut and attach six 12" lengths of shroud line, one to each point of the chute. Use one tape strip to attach each shroud line. Gather the free ends of all shroud lines and tie them together with a small knot as near the end as possible.

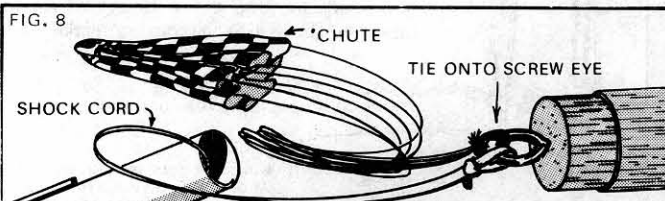

9.) Tie the free end of the shock cord to the screw eye. Also, tie the knotted end of the shroud lines to the screw eye. Temporarily insert the chute, lines, cord and nose cone into the front of the body tube.

10.) Stand the bird gently on its fins. Apply glue the length of the tip plate centering mark on one plate and locate it on the tip edge of one fin. Correct alignment is when the plate is attached at a 90 degree angle to its fin, the centering mark is covered by the fin tip-edge and the trailing edge of the

GENERAL VIEW

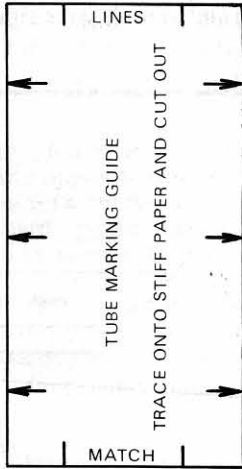
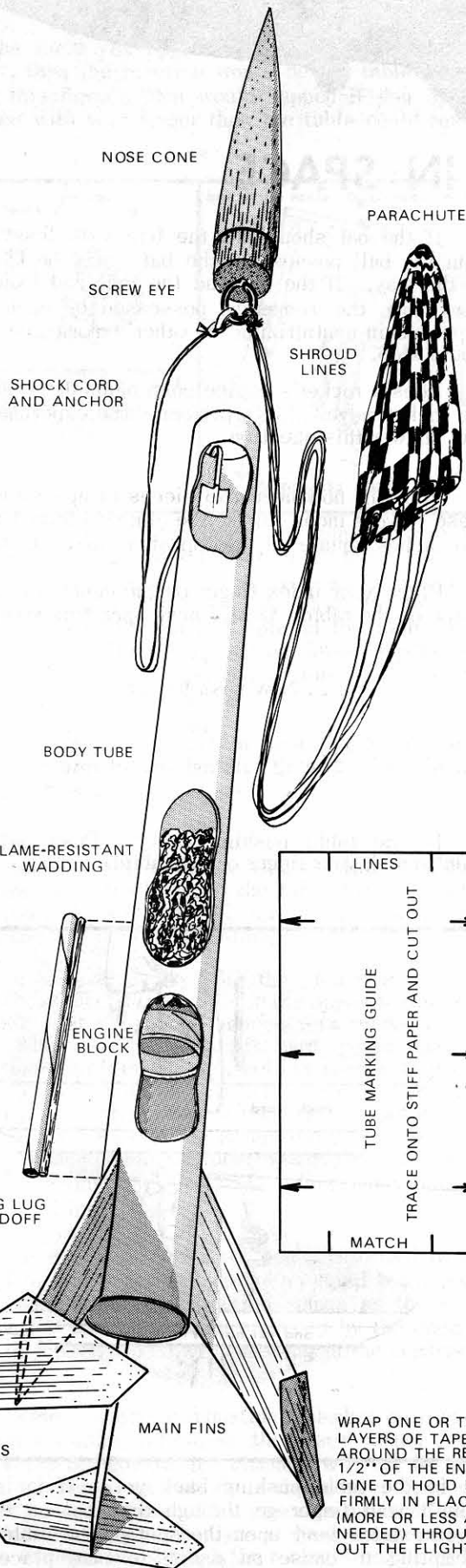

WRAP ONE OR TWO LAYERS OF TAPE AROUND THE REAR 1/2" OF THE ENGINE TO HOLD IT FIRMLY IN PLACE (MORE OR LESS AS NEEDED) THROUGHOUT THE FLIGHT

FIG. 9A

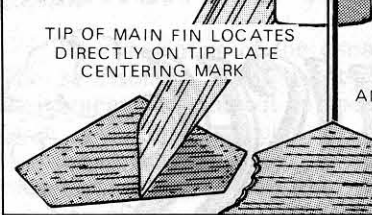

FIG. 9B

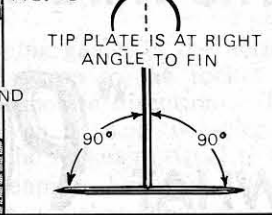

plate is resting flat on the table top. Repeat this step with the other two plates and fins. Stand the bird aside to dry.

11.) There are two ways to mount the launching lug. You may simply apply a line of glue along the lug and place it on the body tube with its trailing edge even with the front edge of the fins, centered between two fins. Or, you may obtain a piece of 1/12" dowel (WD-2) and cut it the length of the launching lug and glue it to the lug, then apply a line of glue to the dowel and align this assembly on the body tube as you would a regular lug. This gives your bird dual capability—you may launch it from a standard rod launcher or from a C-rail launcher.

Prepare to Paint

12.) Give all balsa fin and body tube joints a fillet of white glue and allow to dry. Support the model horizontally while the fillets are drying.

13.) Give all balsa parts a coat of sanding sealer and let dry. Lightly sand, seal, sand and seal again until the surfaces look and feel smooth and all the wood pores are filled.

14.) Give the bird two coats of glossy white enamel, allowing at least two hours drying time between coats. Then apply the color trim of your choice. The original bird had a royal blue nose cone, royal blue fins and tip plates and specially cut decorating tape made the roll pattern. Air Force stars and bars decals on each tip plate supplied the finishing touch.

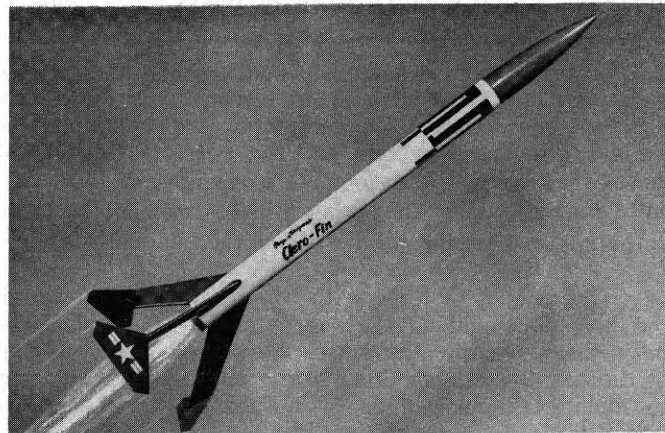

General Information

15.) Three squares of flame-resistant wadding provide protection for the 'chute. Any Series I single-stage engine from 1/2A6-2 on will give a good flight. Have binoculars for tracking and fly on a calm day, however, if you use a C6-7. . . for this engine can put the AERO-FIN nearly out of sight! Use the "Parachute or Streamer" countdown checklist on your Estes Flight Data Sheet.

FIG. 10

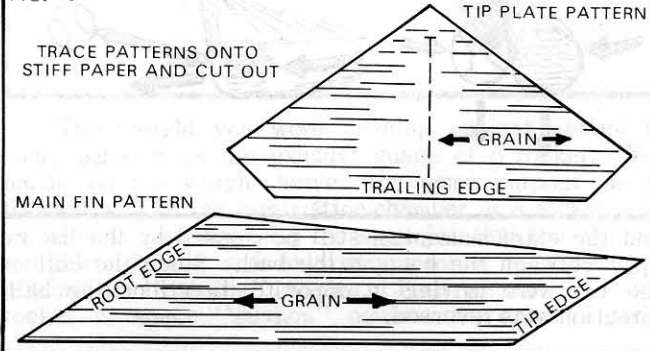

The Third Law of Motion:

"PUSH"

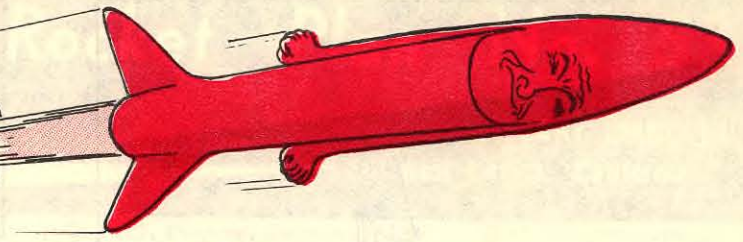

WHAT ROCKETS

AGAINST" IN SPACE

This is an "action" article to help you understand some principles of rocket flight. To get the most from your study follow these instructions:

Whenever ** appears, stop reading immediately and perform the action which has just been called for. Keep thinking and try to reason out why the action was performed as well as what happened when the action was performed. Try to answer each question before going on with your reading.

Remember when you were at bat and someone pitched to you. When you hit the baseball solidly with the bat you caused the baseball to reverse direction and begin traveling rapidly in the other direction. Your action of hitting the ball caused the ball to slow down, stop, reverse direction and begin moving rapidly in the other direction. This required a lot of force. You supplied the force by swinging the bat.

Let's analyze what happened. When the pitcher threw the ball he used a lot of force. This force gave the ball momentum. The momentum depends upon the mass of the moving body and the velocity (speed) of the moving body. Therefore the momentum of the baseball depends upon the mass of the baseball and the velocity at which the pitcher threw the baseball.

The amount of force with which you, the batter, hit the ball depended on the momentum of your bat. The bat's mass remains the same unless you break off part of the bat or add something to the bat. So the only way to change the momentum of the bat is to change its velocity.

The faster you swung the bat the more momentum it had. If your bat had more momentum than the ball, the ball's momentum was overcome by the bat's momentum

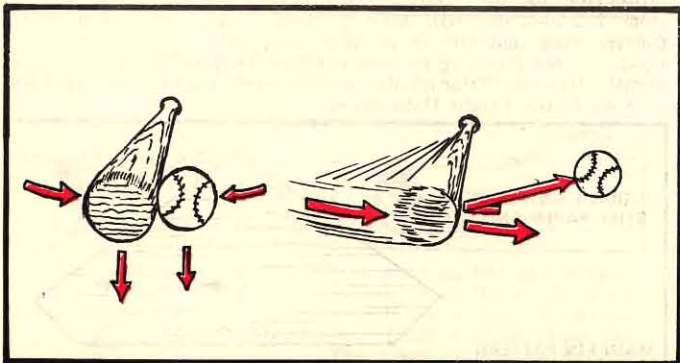

and the extra momentum still possessed by the bat was split between the bat and the ball. Since the ball and the bat were moving in opposite directions the ball's direction was reversed.

If the bat should hit the ball with less momentum than the ball possesses, the bat would be knocked out of the way. If the bat and the ball had exactly equal momentum, the momentum possessed by each would be expended in neutralizing the other's momentum, and both would stop.

Does a rocket's engine push against the air to make the rocket move? Let's perform some experiments which may answer this question.

You will now need two pieces of apparatus. One of these is your index finger, the other a cleared area about two inches square on the top of a strong desk or table.

Place your index finger on the center of the cleared space on the table. Gently push upon this spot.

**

... Now push harder.

**

... Push even harder.

**

Is the table pushing back? Push **still** harder. (Don't break your finger or the table!)

**

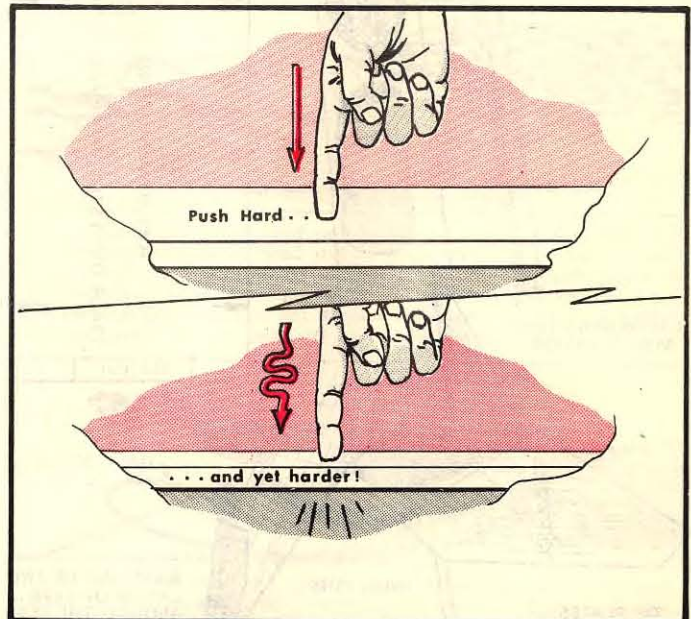

Is the table pushing back yet? If it isn't, why doesn't your finger go through the spot on the table? If you exert a **force** upon the spot on the table, you are attempting to cause an **action** to take place just as swinging the bat was an **action**. The momentum of the

ball hitting the bat produced a *reaction* against the action of the bat. What would be the reaction to the force applied by your finger?

**

If the force you applied with your finger was the "action", then the reaction would be the table's resistance to this force. What would happen if you applied more force with your finger than the table could resist?

**

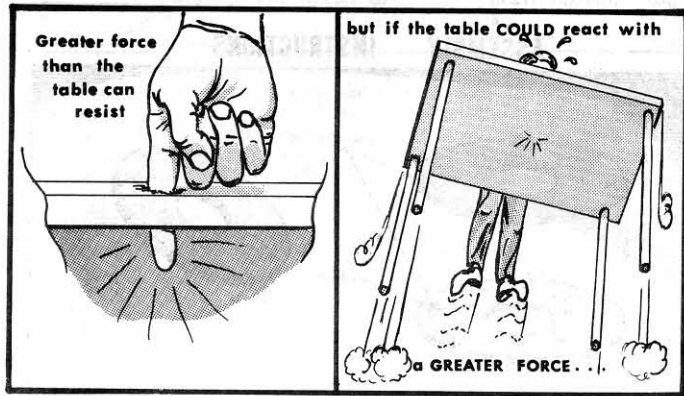

When the force applied is greater than the force with which the object can resist, part of the force being applied will produce motion. When you apply more force with your finger than the force with which the table can react, the finger will punch a hole in the table or the table will move. Since every action always produces an equal reaction, an equal amount of force is present in both the action and the reaction.

If the table could react against the force applied by the finger with a force greater than the force applied by the finger, what would happen?

**

The table would move the finger! However, there is no extra force available to the table for its reaction unless something supplies the force (such as a friend getting under the table and pushing up).

If you have difficulty with the idea that *for every action there is an equal reaction* in the opposite direction, try pushing your two hands against themselves in front of you. When you push equally hard (equal forces or equal actions) with each hand, neither hand gets pushed back (action and equal reaction in the opposite direction). When you push harder with one hand than with the other, both hands move so that the action force (force of pushing with the hand pushing hardest) is equal to the reaction (force of pushing back with the other hand plus the force changed into motion).

All these experiments have been performed to help show that for every action there is an equal but opposite reaction. In a rocket the action comes as the rocket pushes on the escaping gases produced by the chemical reaction of fuel and oxidizer combining in the combustion chamber.

The sides of the combustion chamber prevent the gases from escaping sideways: the gases cannot escape forward since the combustion chamber will not let them. The only opening to the outside is the nozzle. Remember that a tremendous volume of hot gases is produced as the fuel is burned. These hot gases have mass and this mass can escape only through the rocket's nozzle at high velocity. This means that the gases have a large mo-

mentum (the mass of the gases times the velocity of the gases).

The momentum of the escaping gases is the action. The reaction is the momentum given to the rocket by their escape (equal but in the opposite direction). The large mass of the rocket is given a small velocity so that the momentum (reaction) of the rocket is equal to the momentum (action) of the escaping low-mass, high-velocity gases. So what pushes a rocket through space is the unbalanced pressure in its own combustion chamber.

One other experiment you can perform to demonstrate this principle involves turning yourself into a rocket. For this experiment you will need a heavy weight (10 or 20 pounds - a concrete block will do) and a playground swing. Climb on the swing, holding the weight in your lap and pull your feet up off the ground so you are hanging freely. Now, without touching anything but the weight and the swing, throw the weight away from you, straight forward, as hard as you can (be careful you don't hit someone with it). What happened?

**

You and the swing moved in one direction when the weight moved in the opposite direction. Which moved faster - you or the weight?

**

The weight moved faster than you because it was lighter than you. What were you pushing against when you started moving?

**

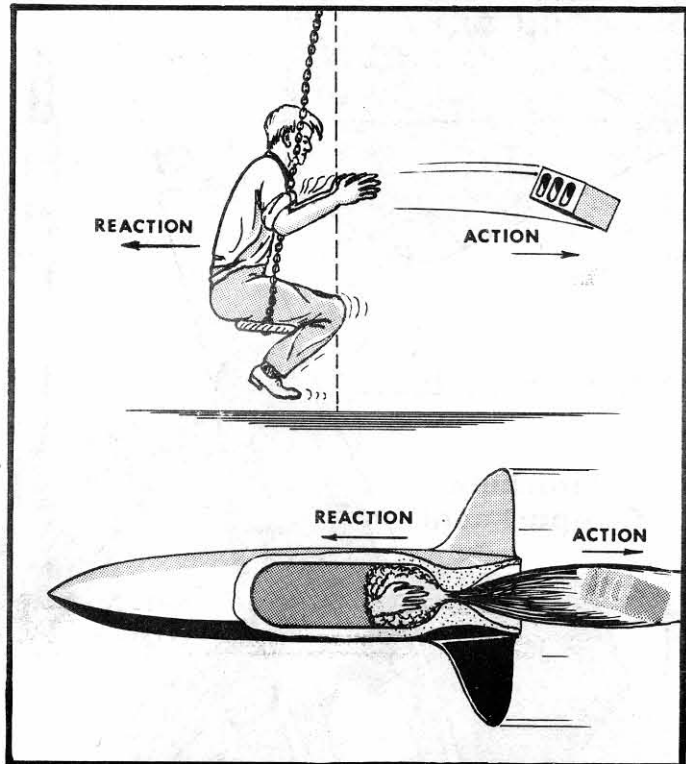

The weight you were pushing against served the same purpose as the exhaust gases of a rocket. Your hands on the weight served the same purpose as the forward wall of the combustion chamber in a rocket. The muscles in your arms did the same job that the chemical reaction of fuel and oxidizer performs in a rocket - getting the "exhaust" moving. Thus we can see that a rocket in space "pushes" against its exhaust gases.

Estes Industries Rocket Plan No. 54

Space Freighter

Estes Design Contest
First Place Winner

Rearward Ejection Payloader By SCOTT AMUNDSON Satellite Beach, Fla.

Published as a service to its customers by Estes Industries, Inc., Box 227, Penrose, Colorado 81240

© ESTES INDUSTRIES, 1968

PARTS LIST

- (A) 1 Payload Section--Part #PS-50A
- (B) 1 Body Tube--Part #BT-50H
- (C) 1 Body Tube--Part #BT-60R
- (D) 1 Body Tube--Part #BT-20J
- (E) 1 Balsa Adapter--Part #TA-5060
- (F) 1 Balsa Sheet--Part #BFS-30
- (G) 4 Paper Adapter Rings--Part #RA-2060
- (H) 1 36" Shock Cord--Part #SC-3
- (I) 1 Launch Lug--Part #LL-2B
- (J) 1 Parachute--Part #PK-18
- (K) 1 Snap Swivel--Part #SV-12
- (L) 1 Gauze Reinforcing--Part #GR-2

ASSEMBLY INSTRUCTIONS

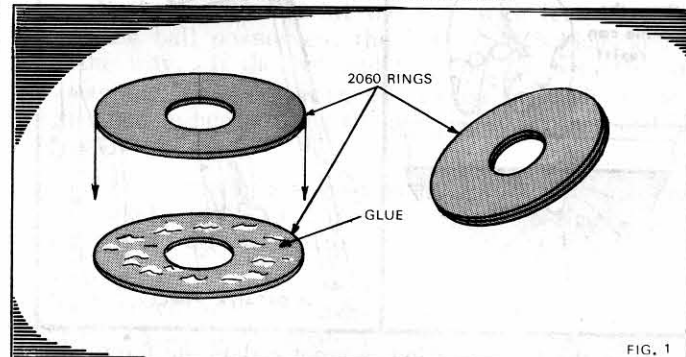

FIG. 1

1. Punch out the four 20-60 paper adapter rings. Spread glue over one side of one ring and press another ring firmly into place so the edges of the two match perfectly. Wipe off any excess glue. Repeat this with the other two rings.

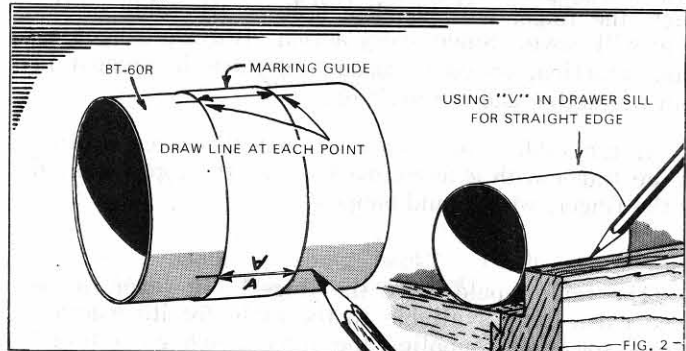

FIG. 2

2. Trace the tube marking guide and the fin pattern onto a piece of fairly heavy paper. Cut out the copies of these patterns you have made. Wrap the tube marking guide around the BT-60R body tube and mark the tube at each of the arrow points. Extend a straight line the length of the tube at each mark using the edge of a drawer notch or other straight "V" groove for a pencil guide. Cut the BT-60R to 3 inches long.

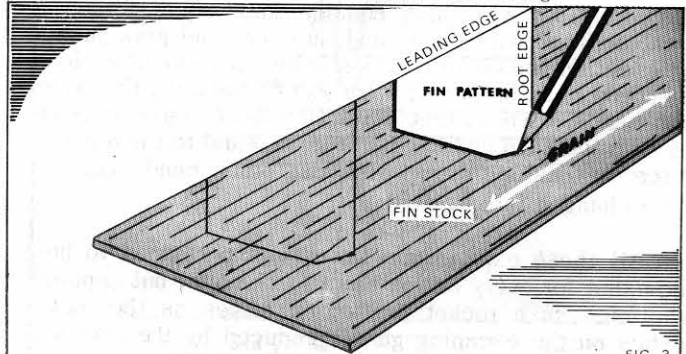

FIG. 3

3. Lay the fin pattern on the balsa fin stock with the grain of the balsa parallel to the leading edge of the pattern. Trace three fins with the pattern positioned in this way. Cut out the fins using a sharp knife. Sand the root edge (the edge that will be glued to the body) of each fin so it is perfectly flat. Sand the other edges until they are smooth and rounded. In one fin cut a small notch as shown for the shock cord attachment.

NOTCH IN ONE FIN ONLY

GRAIN

FIN PATTERN
(Full Size)

100% BALS

Recommended Engines

A8-3 B6-4 B14-5 C6-5
(Use A8-3 engines for first flights.)

Parachute
Compartment

Tube Marking
Guide

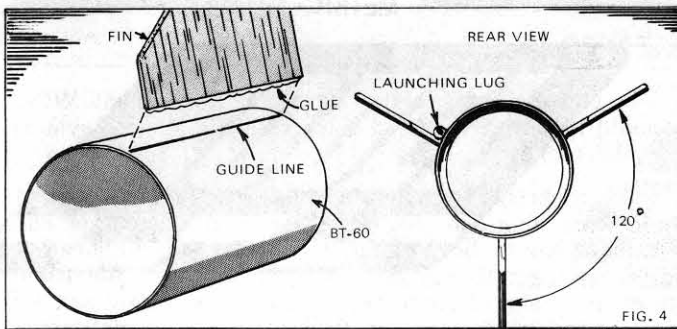

4. Glue the fins to the BT-60 body exactly on the lines made in step 3. To do this, apply glue to the root edge of a fin, hold it for a minute to let the glue get "tacky" and then press the fin onto the body over the line. The fin should stick straight away from the body tube as shown in the rear view. Repeat this step with the other two main fins. Stand the body section on its front while the glue dries. Glue the launch lug to the fin as shown.

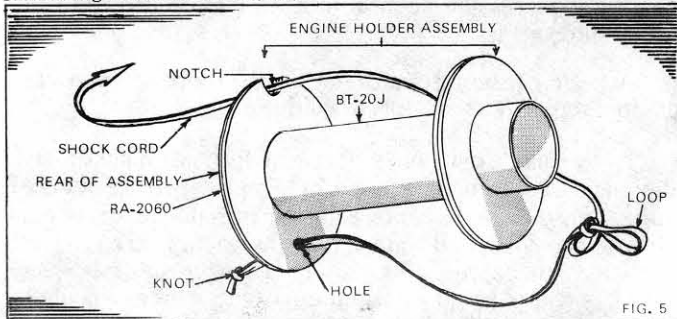

5. Cut a notch and a small hole in one glued pair of rings as shown. Slide the rings onto the BT-20J engine holder tube so the rings are each 1/3" from the ends of the tube. Apply a fillet of glue to all ring-tube joints and smooth the fillet with your finger. Set the unit on its end while the glue dries. Sand the paper rings as necessary so they slip in and out of the tail section.

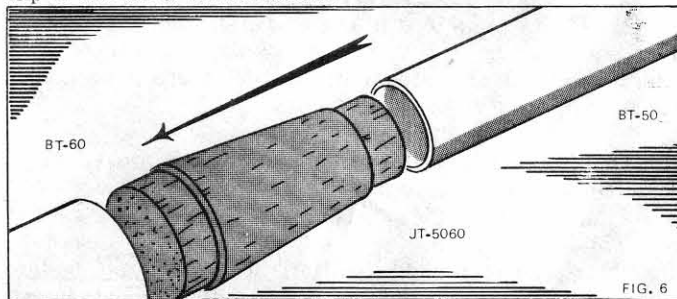

6. Glue the balsa adapter (TA-5060) to the tail section and then also to the smaller body tube (BT-50).

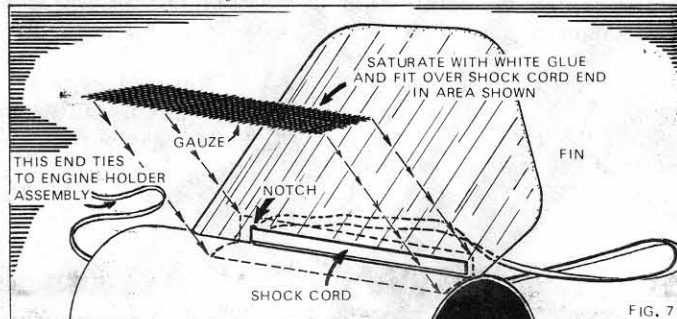

7. Put the end of the 36-inch shock cord through the notch in the fin and using a small amount of rubber cement or contact cement, glue the shock cord along each side of the fin. When the rubber cement has dried, glue a 1/2" X 2" piece of gauze reinforcing material over the shock cord. Use your finger to spread glue fillets (don't use rubber cement for fillets!) on all fin joints and at least three coatings over the shock cord.

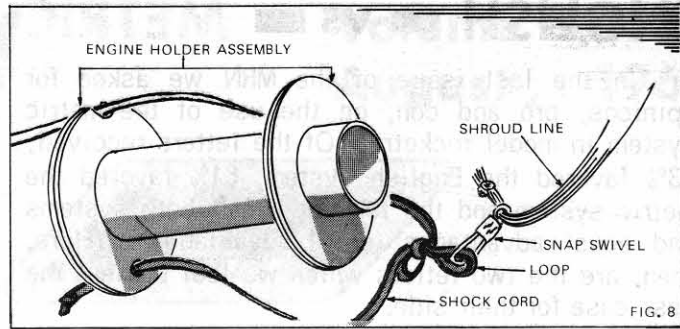

8. Assemble a plastic 18-inch parachute (PK-18) and attach it by tying a snap swivel to the shock cord of the tail section, 2/3 of its length from the fins. Then put the end of the shock cord through the small hole in the ring and tie a knot in the end to prevent it from slipping through.

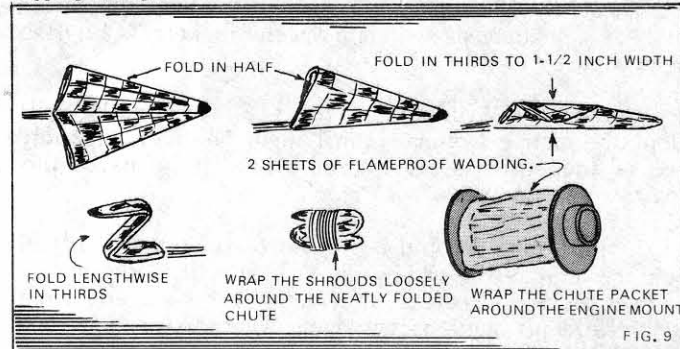

To prepare the rocket for flying, fold the parachute neatly according to the drawing. For this rocket it is especially important to fold the parachute rather than rolling it, since rolling the chute or shroud lines around the engine mount will usually result in an unopened tangled chute.

General Assembly View

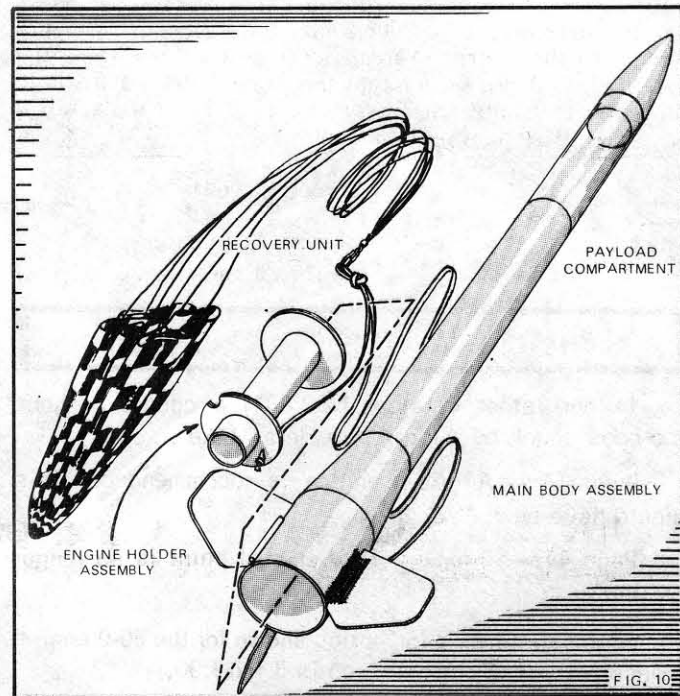

CONTEST WINNERS

Results of judging in the 1968 Estes Single Stage Design Contest (see Notes from the Boss, page 4) were formally announced by the Estes Industries Research and Development staff August 1. Those receiving awards were:

FIRST PLACE including a \$50 merchandise award, went to Scott Amundson, Satellite Beach, Florida, for his Space Freighter payload model.

The **SECOND PLACE** \$25 merchandise award was presented to Don Silar, Willow Street, Pennsylvania, who submitted the Andromeda, a high-performance sport model.

THIRD PLACE with \$10 in merchandise, was taken by Paul Kohlberg, Westlake, Ohio, for his Comet, a high-performance competition model.

FOURTH PLACE award of \$5 in merchandise went to J. T. Kealey, Harrisburg, Pennsylvania, whose 8-Ball design featured fins and fillets made from body tubing.

ENGLISH vs METRIC

METRIC

In the last issue of the MRN we asked for opinions, pro and con, on the use of the metric system in model rocketry. Of the letters received, 33% favored the English system, 61% favored the metric system and the remainder felt both systems had equal advantages (or disadvantages). Here, then, are the two letters which we feel present the best case for their side.

ENGLISH

Dear Sirs:

I am writing in reply to your request for opinions on the best measurement system for model rocketry — English or metric.

Personally, I think that the U.S., eventually, will adopt the metric system. Until then, however, probably 95% of the nation's population will still be using the English system.

I think that it would be futile to convert U.S. model rocketry (unless the whole nation changed) to the metric system for a number of reasons. First of all, most modelers don't have metric measuring instruments and probably are not too familiar with the system. Also, it would be of great inconvenience for us to change all of our graphs, tables, charts, etc., from English measures to metric measures overnight. Furthermore, a company like Estes who produces model rocket supplies doesn't have the equipment to make supplies in metric dimensions, and it would be costly for them to install this type of equipment in their factories, until the rest of the nation was converted.

In summary, I believe that model rocketry should change to the metric system if and when the rest of the U.S. does. Also, I feel that model rocketry as a whole should not change until everyone else does because of the difficulties it would encounter.

Sincerely yours,

Robert C. Pearson
Tower, Minnesota

We goofed

In our latest catalog (No. 681) a couple of good boo-boos snuck by the proof-readers. Like . . .

Page 19 — An A5-3 engine is recommended. This should have been "A5-2".

Page 44 — Chrome yellow enamel paint is no longer available.

Page 49 — The "3 for" price shown for the B6-0 engine is incorrect. The correct price is 3 for \$90.

Page 50 — In the explanation of engine designations the wrong newton-to-pound conversion factor is shown (#2). The figures shown on page 51 are correct.

Dear Mr. Estes:

In connection with the invitation in the last MRN, I should like to express my support of the metric system in model rocketry.

To rocketeers engaging only in sport flying, it would seem that one system is as good as another and that there would be nothing gained by switching. For individual sport flying, this is probably true. When one enters the realm of contests, however, the metric system is a necessity since record flights must be homologated (approved or confirmed) through its use. International records now being established, it seems only reasonable that one system be adopted for all records. Only a few countries still use the English system, and its originator plans to forsake it in the near future; in coming years only the U.S. will be maintaining its use, contrary to the rest of the world. . .

Outside of the international arena, there are two very common-sense reasons for switching:

1. All mathematics is simplified; small masses and large masses can be compared by simply shifting decimal points; no extra constants must be introduced when calculating complicated quantities such as drag; all quantities are expressed as decimal powers of grams and meters — there is no duplication (e.g., ounces, pounds, slugs) as in the English system. Finally, as calculations become more complex (involving, say, power outputs of transmitters or heat flow) the application of the metric system can greatly simplify problems involving several seemingly complex factors.

2. If the rocketeer plans to pursue an engineering or science career, it is to his advantage to obtain a good grasp of the metric system early in life; there is no doubt that he will have to use it eventually.

Thus, it appears the metric system, at worst, does not adversely affect any rocketeer. The sport flyer need only change those few numbers (such as engine class) with which he must be familiar. To the serious student of rocketry, an increased familiarization with the system will simplify math as well as prepare him for any future science endeavors. The transition could, however, be greatly aided by publication of conversion factors and metric equivalents of vital quantities (e.g., air density).

In light of these matters, a switch, while temporarily inconvenient, would be to every rocketeer's advantage. It is to the credit of Estes Industries that it encourages comment on this important subject.

Yours,

Lindsay Audin
Troy, New York

Estes Industries will attempt to take care of both the English system users and the metric system users. As much as possible we'll try to convert to showing measurements which are convenient for both groups. If you have any comments or suggestions as to what would help you, please let us know.