

K-30

LITTLE JOE II

SPECIFICATIONS

Length	14.5"
Body Dia.	2.217"
Fin Span	4.9"
Weight	2oz.

Only \$2.75

RECOMMENDED ENGINES

A5-2	A8-3
B4-2	B6-4
C6-5	

Parts List

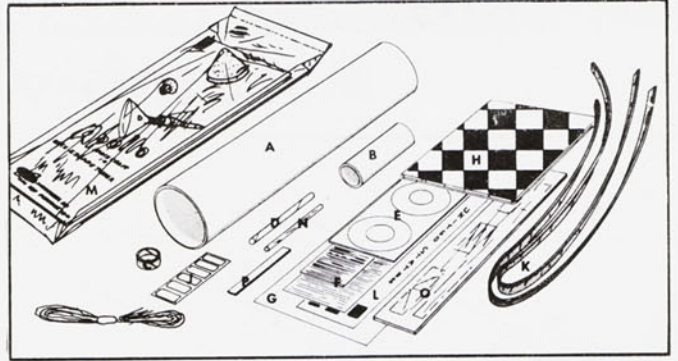

Your LITTLE JOE II kit consists of the following parts as illustrated in the drawing above.

- (A) 1 body tube – Part #BT-70
- (B) 1 engine tube – Part #BT-20J
- (C) 1 engine block – Part #EB-20A
- (D) 1 launch lug – Part #LL-2B
- (E) 2 adaptor rings – Part #RA-2070
- (F) 2 wrap-on panels – Part #SP-30, A and B
- (G) 1 pattern sheet – Part #SP-30
- (H) 1 parachute – Part #PK-18A
- (I) 1 shroud line – Part #SLT-1B
- (J) 6 tape strips – Part #TD-2
- (K) 2 shock cords – Part #SC-1
- (L) 1 decal sheet – Part #KD-30
- (M) 1 capsule kit – Part #NCK-29
- (N) 1 wood dowel – Part #WD-2A
- (O) 1 die-cut balsa sheet – Part #BF-30
- (P) 1 nose cone weight – Part #NCW-3

In addition to the materials included in your kit, you will need the following tools and supplies.

- 1) Extra strong white glue
- 2) Modeling knife or single edge razor blade
- 3) Scissors
- 4) Ball point pen or pencil
- 5) Fine and extra fine sandpaper
- 6) Sanding sealer and paint or dope

Read the entire assembly instructions carefully before beginning work on your rocket. Then start construction following each step in order, checking off each step as it is completed.

ESTES INDUSTRIES, INC. 
Devoted to Safety and Education in Rocketry

BOX 227 PENROSE, COLORADO 81240

LITTLE JOE II

Assembly Instructions

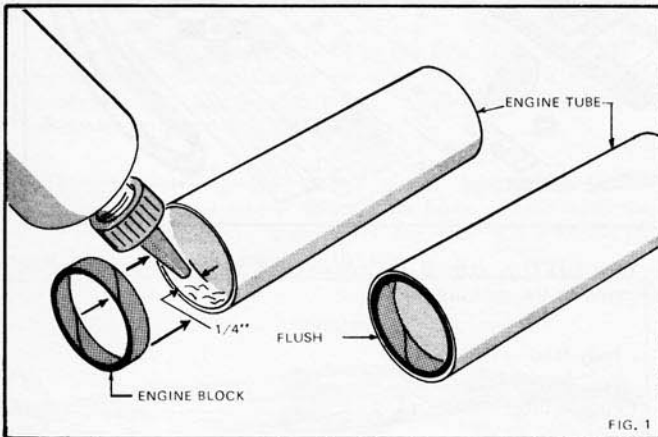

1. Glue the engine block (part C) into one end of the engine holder tube (part B). To do this, spread glue around the inside of one end of the engine tube to cover about 1/4". Slide the engine block into this end of the tube until it is flush with the end as shown in the illustration above.

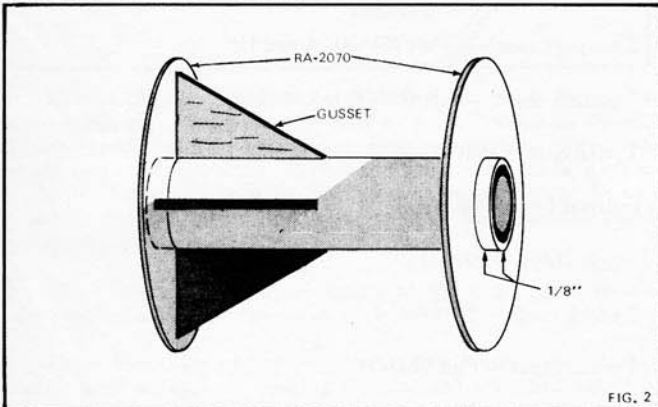

2. Punch out the two RA-2070 rings (part E). Glue one ring on each end of the engine tube about 1/8" in from each end. Punch out the four engine mount gussets from the die-cut balsa (part O) and glue them into place as shown in fig. 2. After the glue has dried, run a fillet of glue along all joints. Set this assembly aside to dry thoroughly.

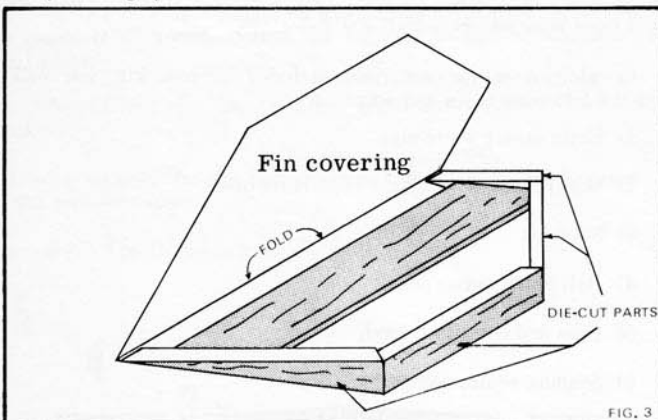

3. Cut the fin coverings from the pattern sheet. Pre-fold the coverings so that the word "Fold" is toward the inside. Punch out the die-cut fin framework pieces (part O) and sand slightly if needed to the proper size as shown on the pattern card (part G) or as shown in fig. 3. Then assemble as shown above.

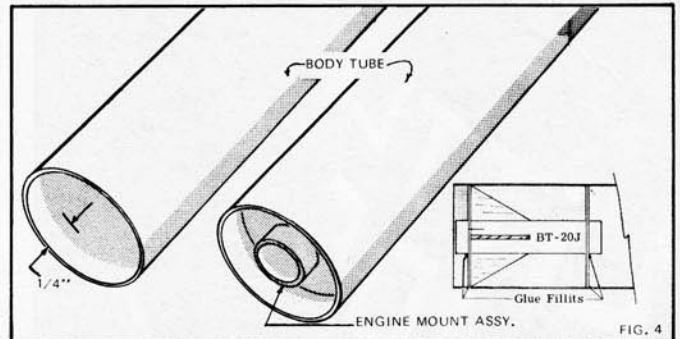

4. Check the illustration above to see how the engine holder assembly fits in the body tube. Mark the inside of the body tube (part A) 1/4" from one end. Check the engine holder assembly's fit in the body. If the rings are too large they can be sanded to size. Spread a ring of glue around the inside of the tube about 2 1/2" in from the marked end. Immediately slide the engine holder assembly into the body tube until the rear ring is even with the 1/4" mark. Keep the engine mount moving while placing it inside the body tube. If you stop or slow down the mount can stick in the wrong place. After the mount is in place run a fillet of glue around the rear ring/body tube joint and set the tube on its front end to dry.

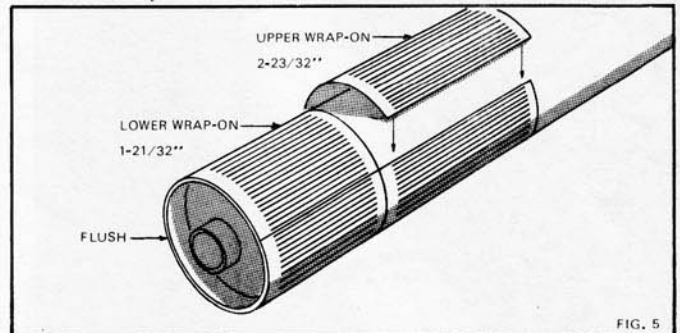

5. Roll the lower wrap-on (part F) around the tube. While you have the wrap-on around the tube, line up the lower edge of the wrap-on with the lower end of the tube and draw a line on the tube around the upper edge of the wrap-on. Remove the wrap-on, spread a thin film of glue around the tube and roll the wrap-on back into place. The upper wrap-on is applied in the same manner as the lower one. Make sure the edges of the wrap-ons are tightly together and the end joints are in line.

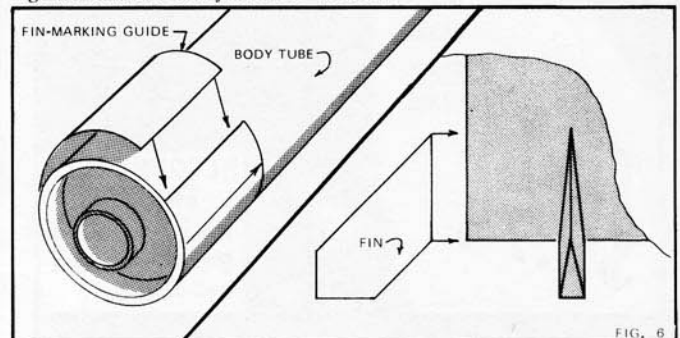

6. Cut out the fin marking guide (part G) and wrap it around the rear of the body tube. Mark the body tube at the points of the arrows. (Be sure the points are located over valleys in the corrugations.) Remove the guide and extend the mark up the body about 2". Spread glue on the root of one of the fins and carefully position it on one of the fin lines. Line up the fin by sighting down the tube. Repeat this step with the other three fins.

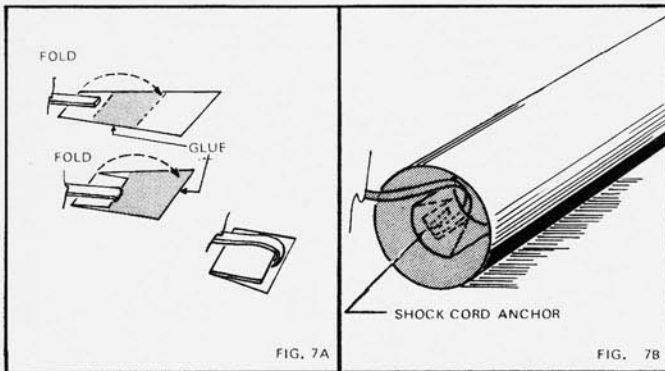

7. Cut out the shock cord mount from the pattern sheet and assemble it with one shock cord (part K) as shown in fig. 7A. Spread glue over a 1" square area on the inside of the body tube, at least 1-1/2" in from the front end of the tube. Lay the shock cord mount onto the glue and press it down into the shape of the tube. After the glue has set a thin layer of glue may be spread over the shock cord mount.

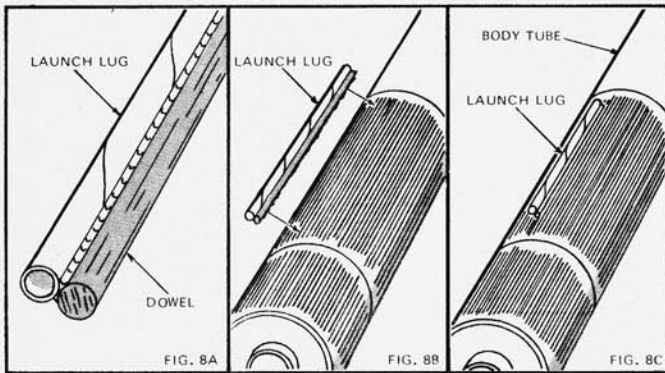

8. The launch lug assembly can be used with both the standard 1/8" rod and the "C" channel rail. Cut the dowel (part N) to the same length as the launch lug (part D). Glue the lug to the dowel as shown in fig. 8A. After this assembly is dry apply a line of glue to the dowel as shown in fig. 8B. Attach the assembly to the rocket in a valley between corrugations as illustrated in fig. 8C. (If you will not be using a "C" channel rail launcher, the dowel can be left out and the launching lug glued directly to the body.) Coat the dowel with a thin layer of glue to strengthen the assembly.

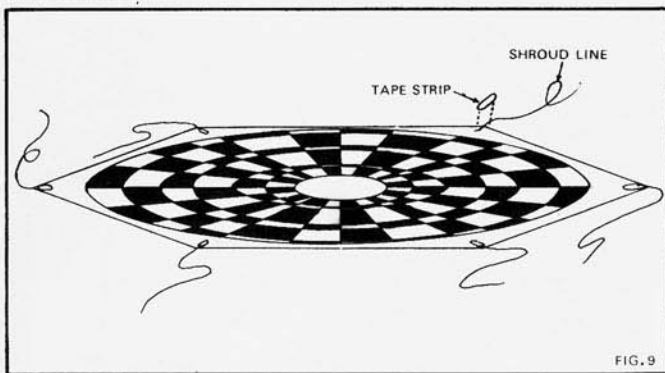

9. Cut out the parachute (part H) on its edge lines as indicated on the plastic. Cut six 18" lengths of shroud line cord (part D) and attach one shroud line to each point of the parachute with a tape strip (part J) as shown above. Tie the free ends of the lines together in a loop. Tie the end of the shock cord into this loop.

CAPSULE ASSEMBLY

10. The Apollo Capsule and escape tower (part M) are assembled according to the instructions included in the capsule kit except for the following differences:

A) Capsule Assembly Step 1. Before gluing the nose cone into the escape motor tube, roll the nose cone weight (part P) into a tight coil. Check to make sure the coil will fit inside the tube, then smear a heavy layer of glue all over the first 1/2" of the inside of the tube. Slide the weight into the tube, then slide the nose cone in behind it. Wipe off any excess glue from the outside of the joint. Support the tube with the nose cone down for the next hour or so until the glue can dry to hold the weight in place.

B) Capsule Assembly Step 3. The Little Joe II was used to launch "boiler plate" capsules. For this reason the capsule shroud should be formed with its printed side to the inside to hide the detailing.

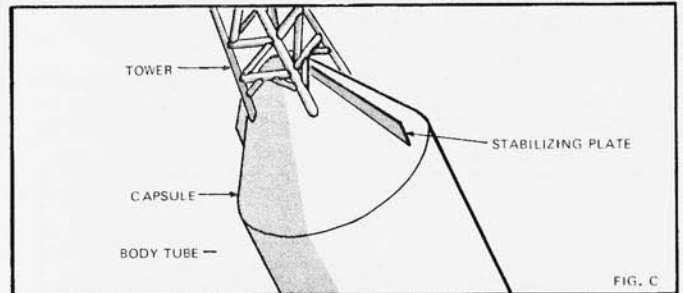

C) Capsule Assembly Step 14. After completing this step, cut out the stabilizing plates from the pattern sheet (vehicle kit part G) and glue them in place as shown in the capsule assembly illustration above.

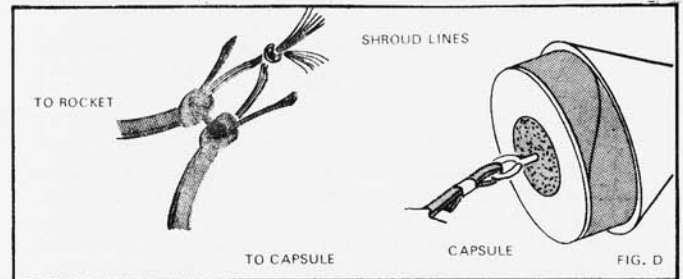

D) After capsule assembly is completed, tie one end of the remaining shock cord (part K) of the vehicle kit to the screw eye at the base of the capsule. Tie the other end to the loop in the parachute shroud lines as shown.

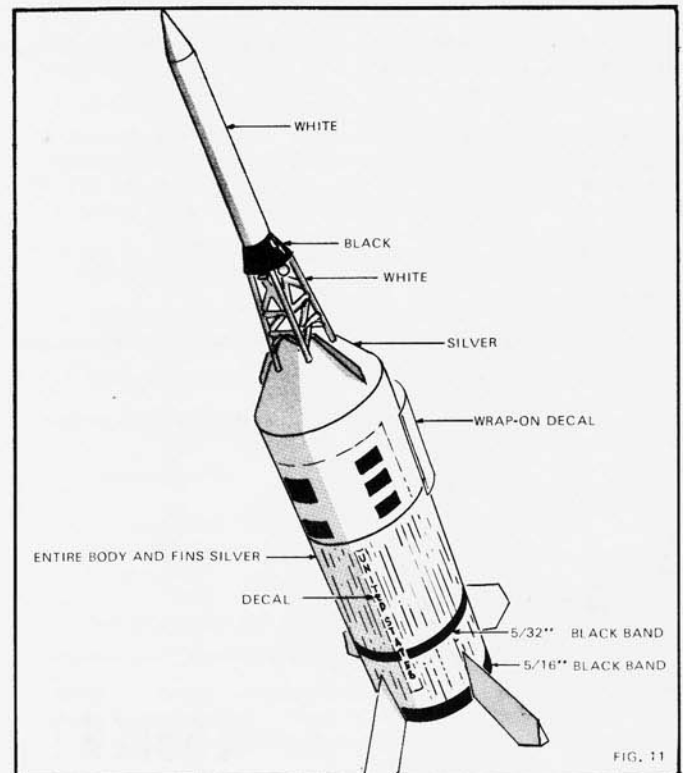

11. Apply a light coat of sanding sealer to all exposed balsa parts. When the sealer is dry, sand the parts lightly (but thoroughly). Apply a second coat of sealer let dry and sand some more. Repeat this until the pores in the wood are filled, then give the model at least one base coat of white paint. Follow with aluminum, black and the decals as shown fig. 11.

COUNTDOWN CHECKLIST

The engine types recommended for use in this model are the A5-2, A8-3, B4-2, B6-4 and C6-5. For the first test flights B4-2 engines should be used. Launch on calm days. Use a standard electrical launching system with either an LR-18A "C" rail or a 1/8" diameter guide rod at least 36" long.

-14- Loosely crumple six or seven squares of flame-resistant wadding and place it into the body. Make sure the wadding covers the entire diameter of the tube and extends for at least 1-1/2" along the inside of the tube.

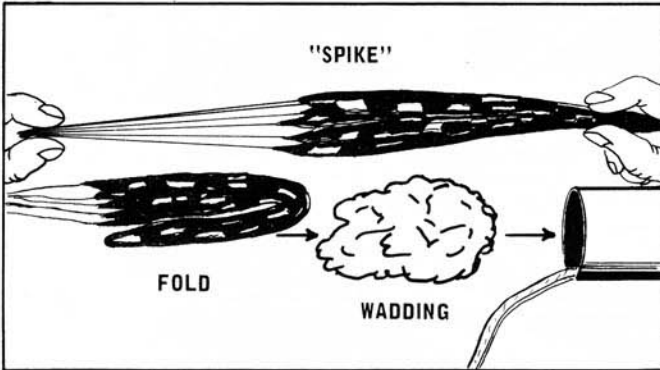

-13- Hold the parachute between two fingers at its center and pass the other hand down it to form a "spike" shape as shown. Fold the "spike" into three sections. Wrap two squares of wadding over the end of the parachute after it is folded, ready to be packed into the body tube. This gives the chute extra protection. Insert the shock cord and shroud lines into the body and place the parachute in on top. Slide the capsule into place.

-12- Install an electrical igniter in the engine as directed in the instructions which came with the engine.

-11- Insert the engine into the engine holder tube on the model. Wrap a layer of masking tape around the joint between tube and engine as shown.

-10- Remove the safety interlock or key from the launch control panel. (If a simple spring switch is used, install the protector on the switch to separate the contacts.) Carry the key or interlock on the person of the launch control officer.

-9- Place the rocket on the launcher. Check to be sure the panel is disarmed. Clean the micro-clips and attach them to the igniter.

-8- Clear the launch area, alert the recovery crew and trackers.

-7- Check for low flying aircraft and unauthorized persons in the recovery area.

-6- Arm the launch panel.

Designed and produced for NASA by General Dynamics Convair, San Diego, California, the Little Joe II is a solid-propellant booster that was used to launch Apollo spacecraft into suborbital trajectories. The purpose of these launchings was to prove out the spacecraft's launch escape system under the maximum stresses which would be encountered in an actual Saturn launching. The illustration below shows a typical flight profile—in this case that of the qualification test vehicle.

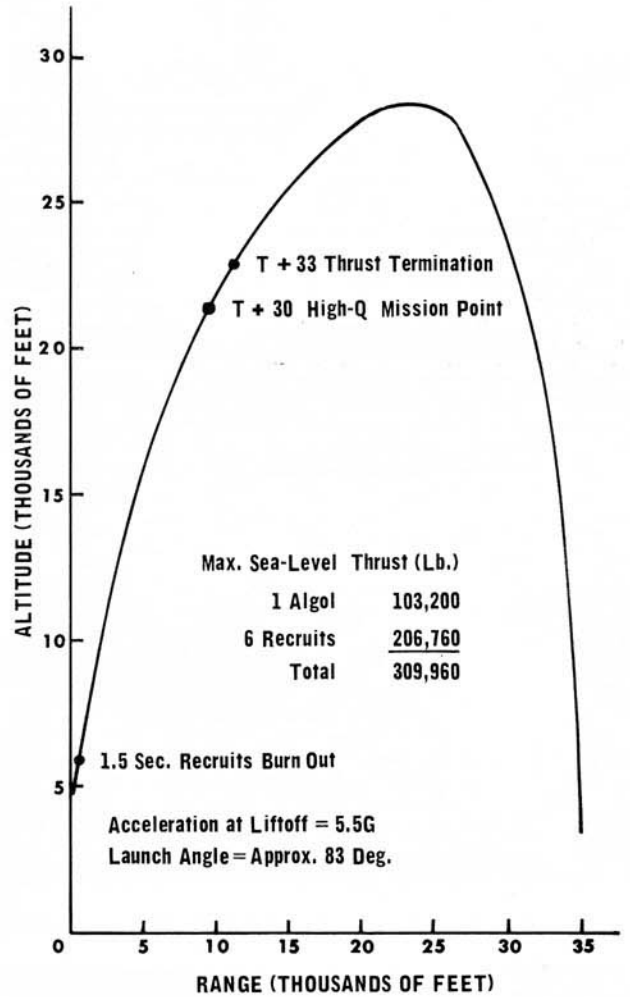

5
4 -
3 -
2 -
1 - LAUNCH!