

ESTES SUPER BIG BERTHA™

FLYING MODEL ROCKET

- THE BIGGEST "BIG BERTHA"™ EVER.
- OVER 3 FEET TALL AND 2 1/2 INCHES IN DIAMETER!
- BLAST-OFF WITH D12-5 MODEL ROCKET ENGINES

YOU'LL LOVE TO WATCH THIS ROCKET FLY



This is a model kit requiring assembly. Glue and finishing supplies, launch system and engines for flight are not included.
 1 MODELE REDUIT Peinture et colle non comprises.
 USE ONLY WITH ESTES PRODUCTS. Recommended for Ages 10 Through Adult.
 Adult Supervision Suggested for Those Under 12 Years of Age.



www.estesrockets.com

MADE IN U.S.A.

ESTES SUPER BIG BERTHA™

Flying Model Rocket #216!

SKILL LEVEL 2 Recommended for the Experienced Modeler.

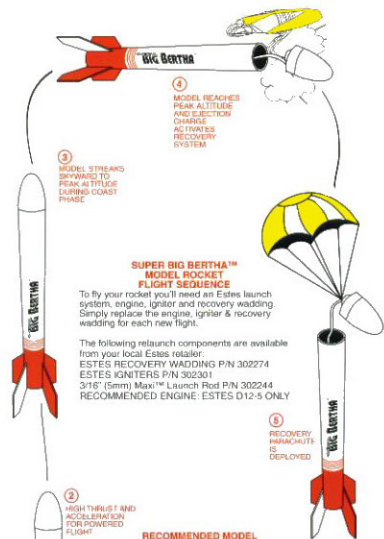

RECOMMENDED MODEL ROCKET LAUNCH AREA:
 Minimum Launch Site Dimension for Circular Area is Diameter in Feet, and for Rectangular Area is Shortest Side in Feet.

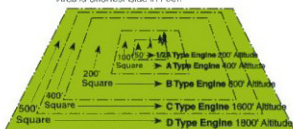

Choose a large field away from power lines, tall trees, and low-flying aircraft. The larger the launch area, the better your chance of recovering your rocket. Football fields, parks, and playgrounds are great. This diagram shows the smallest recommended launch areas. MAKE SURE THE LAUNCH AREA IS FREE OF OBSTRUCTIONS, DRY WEEDS, BROWN GRASS, OR HIGHLY FLAMMABLE MATERIALS.

Model rocketry is a rewarding hobby for ages 10 through adult. Adult supervision recommended for those under 12 years of age. NOTE: Complete instructions are enclosed.

1 MODELE REDUIT PEINTURE ET COLLE NON COMPRISES

FULL ONE YEAR WARRANTY AND SAFETY CODE ENCLOSED.

This rocket has been designed specifically for use with Estes products only.



MADE IN U.S.A.



www.estesrockets.com

Big Bertha is a registered trademark of Centuri Corp.

ESTES INDUSTRIES
 1295 H STREET
 PENROSE, CO 81240

© 1989/2000 Centuri Corp.

(2/00) P/N 81949



4

- A. Apply glue around the engine mount tube as shown.
- B. Slide the hook retainer tube onto the front of the engine mount tube and down over the glue, stopping at the 1 inch mark. Remove the masking tape.

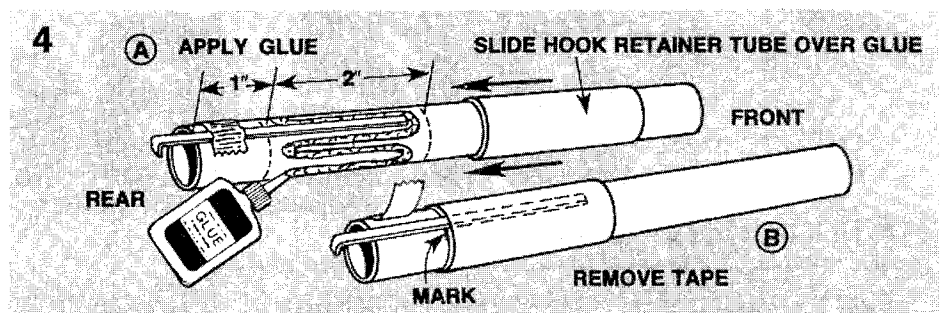

5

- A. Apply glue around the engine mount tube just behind the retainer tube. Slide one of the die-cut rings onto the tube and up against the retainer tube.
- B. Mark the forward end of the engine mount tube 4 1/4 inches from the end. Slide one of the die-cut rings onto the tube and position it on the mark. Apply glue around both sides of the ring where it touches the engine mount tube. Allow the glue to dry.

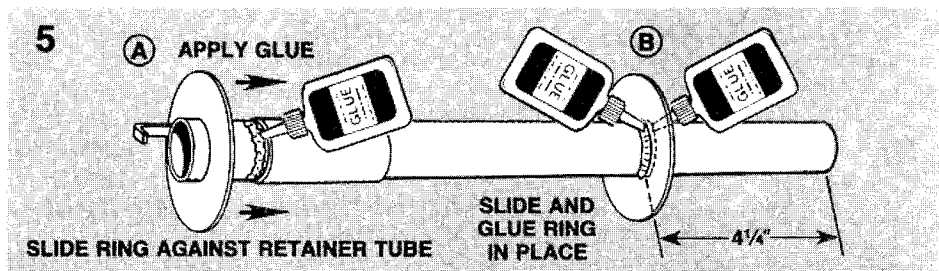

6

- A. Apply glue around the inside of the large body tube just behind the tube coupler.
- B. Slide the completed engine mount into the body tube and up against the tube coupler as shown.
- C. Apply glue around the inside of the rear of the body tube where it touches the die-cut ring.

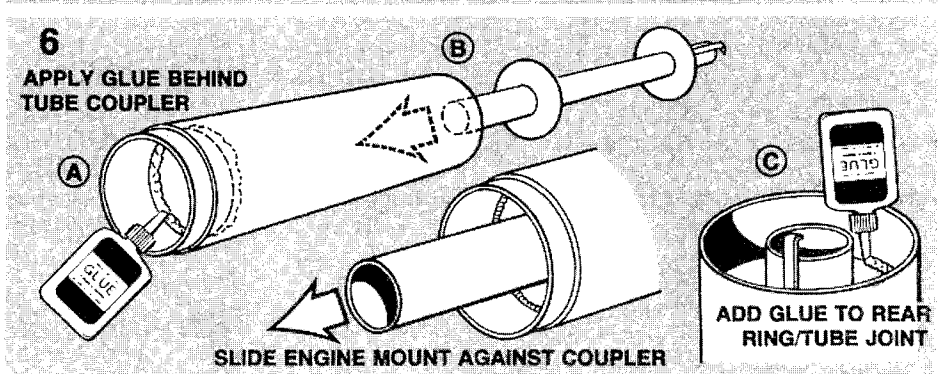

7

- A. Apply glue to the edge of the tube coupler. Slide a die-cut ring onto the protruding engine mount tube and seat it all around the tube coupler. Apply glue around the ring where it touches the tube.
- B. Slide the remaining die-cut ring onto the engine mount tube 1/16 inch from the end. Apply glue around both sides of the die-cut ring where it touches the tube. Allow the glue to dry.

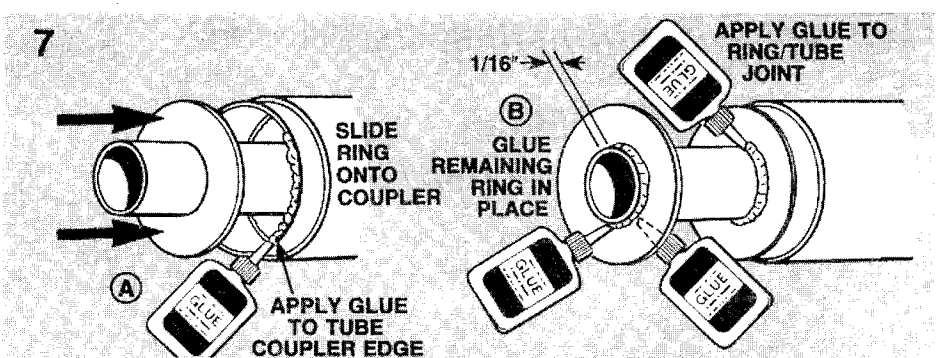

8

- A. Apply glue around the inside of the remaining large body tube about 1 inch from one end. Apply glue around the outside of tube coupler as shown.
- B. Join the body tubes by pushing them together as shown. Wipe away any excess glue. Make sure tubes are straight.

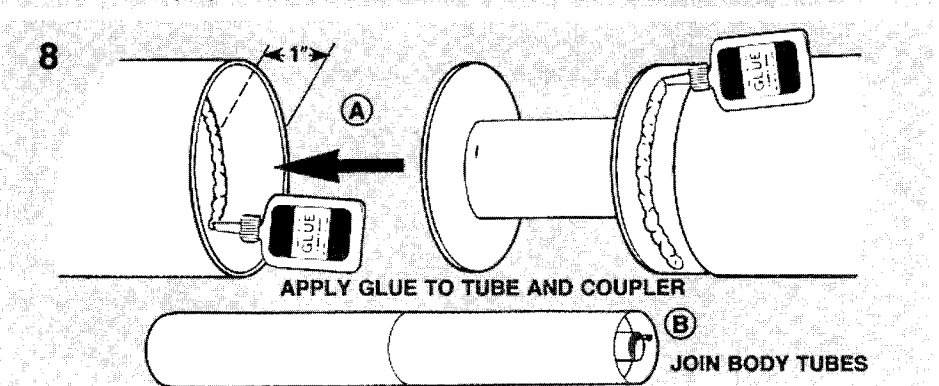

9

- A. Cut out tube marking guide from pattern sheet.
- B. Wrap guide around the tube and tape. Mark tube at arrows. Remove guide.
- C. Draw straight lines connecting each pair of marks. Extend launch lug line to tube joint.

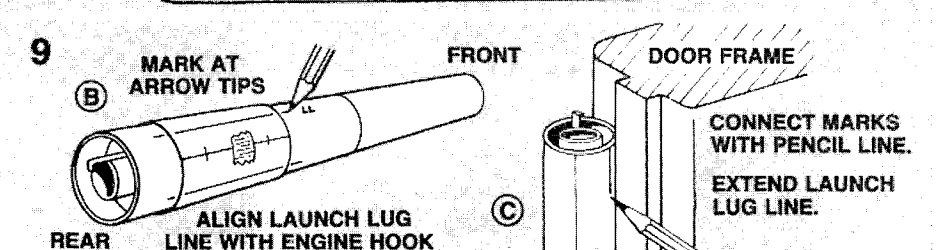



ESTES INDUSTRIES
1295 H Street
Penrose, CO 81240

SUPER BIG BERTHA™

PARTS AND SUPPLIES

FLYING MODEL ROCKET
KIT

ASSEMBLY TIP #2165

Locate the parts shown below and lay them out on the table in front of you.

Read all instructions before assembling your model.

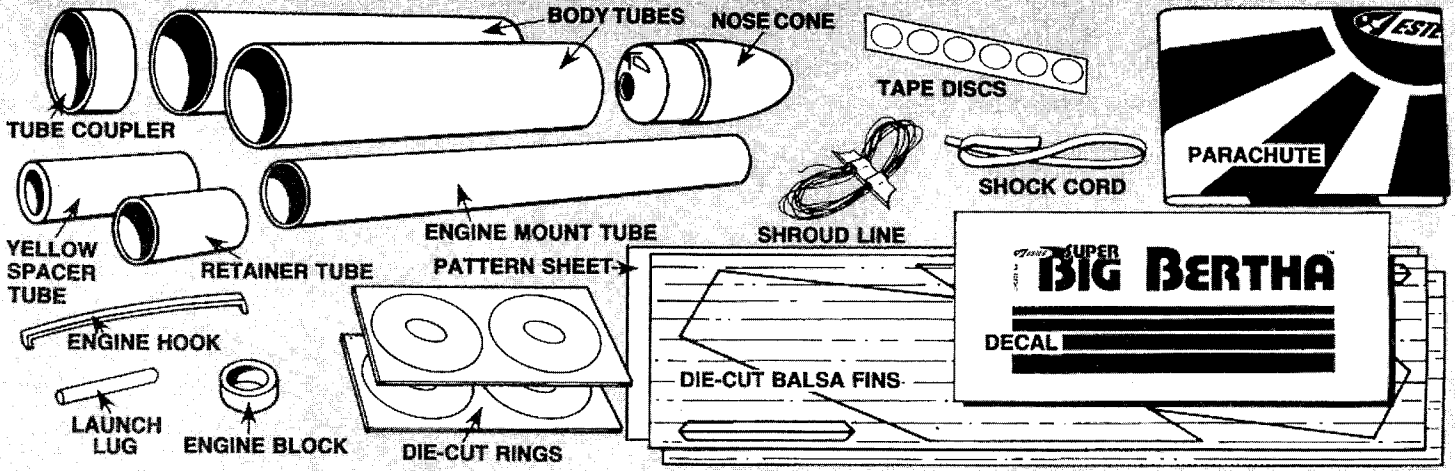

In addition to the parts included in the kit you will also need.

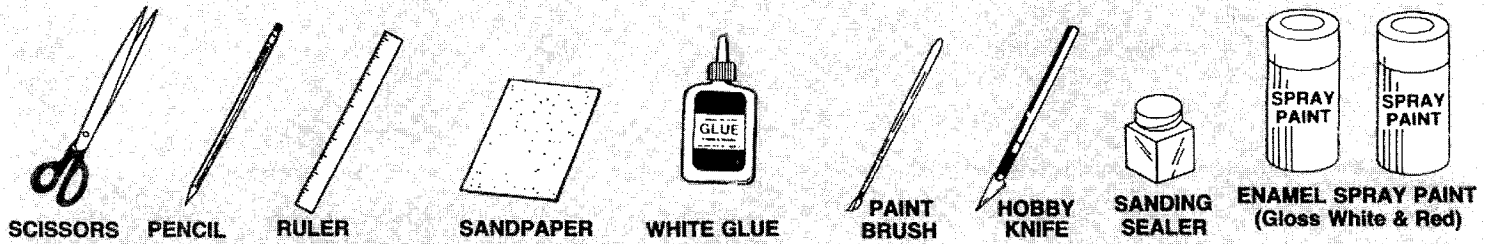

ROCKET ASSEMBLY

- 1**
 - A. Mark the tube coupler 1/2 inch from one edge at 3 or 4 places.
 - B. Place a band of glue around the inside edge of one end of one of the large body tubes.
 - C. Push the tube coupler into the tube until the marks are even with the end of the tube.
- 2**
 - A. Mark the YELLOW spacer tube 1/2 inch from one end.
 - B. Place a band of glue around the inside of the engine mount tube about 2 inches from one end.
 - C. Insert the engine block into the tube and push into place with the YELLOW spacer tube. Stop when mark is even with the end of the tube. Remove and discard the spacer tube immediately.
- 3**
 - A. Mark the end of the engine mount tube with the engine block at 1 inch and 2 1/4 inches. Cut a 1/8 inch wide slit at the 2 1/4 inch mark.
 - B. Apply a line of white glue from slit rearward to the 1 inch mark. Push one end of the engine hook into the slit and align it straight on the tube. Hold the hook in place with masking tape.

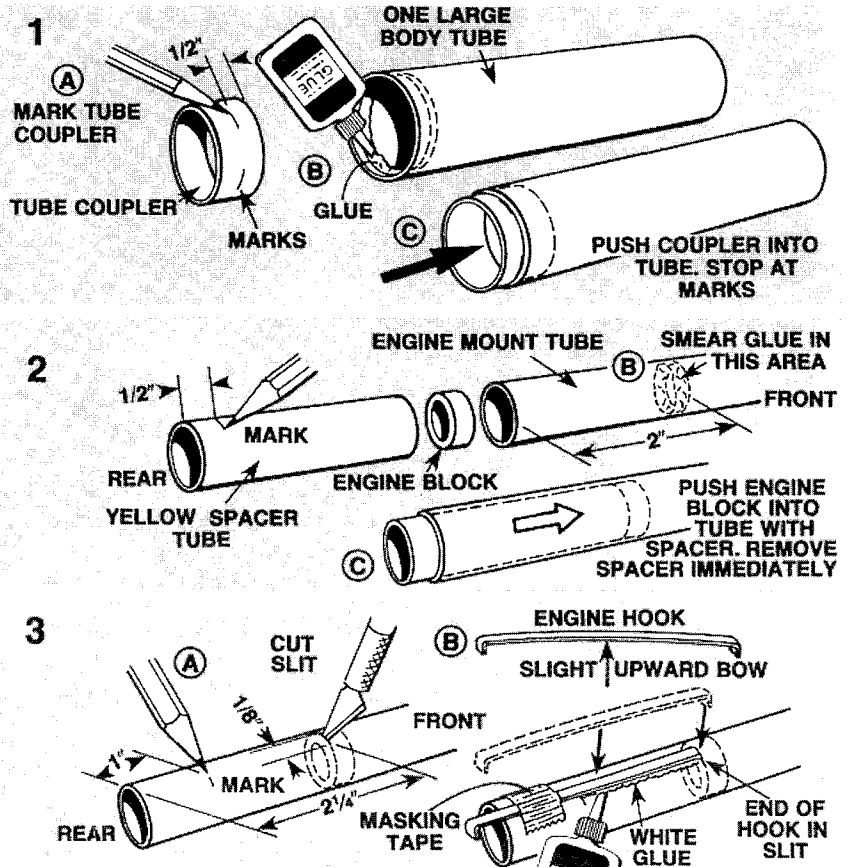

10

- Fine-sand balsa die-cut sheets. Carefully remove parts by freeing edges with sharp knife.
- Stack fins and fin gussets together. Sand all edges smooth.
- Apply glue to the root edge of a fin. Glue fin next to alignment line. Repeat for other fins. Apply each fin on same side of its fin alignment line. Let each fin dry several minutes before applying the next fin.
- Glue fin gussets to body tube/fin joints as shown.
- Looking at the rocket from the rear, the fins should be in the positions shown with the trailing edge of each fin even with the end of the tube.

FINS MUST BE ATTACHED CORRECTLY FOR STABLE FLIGHT

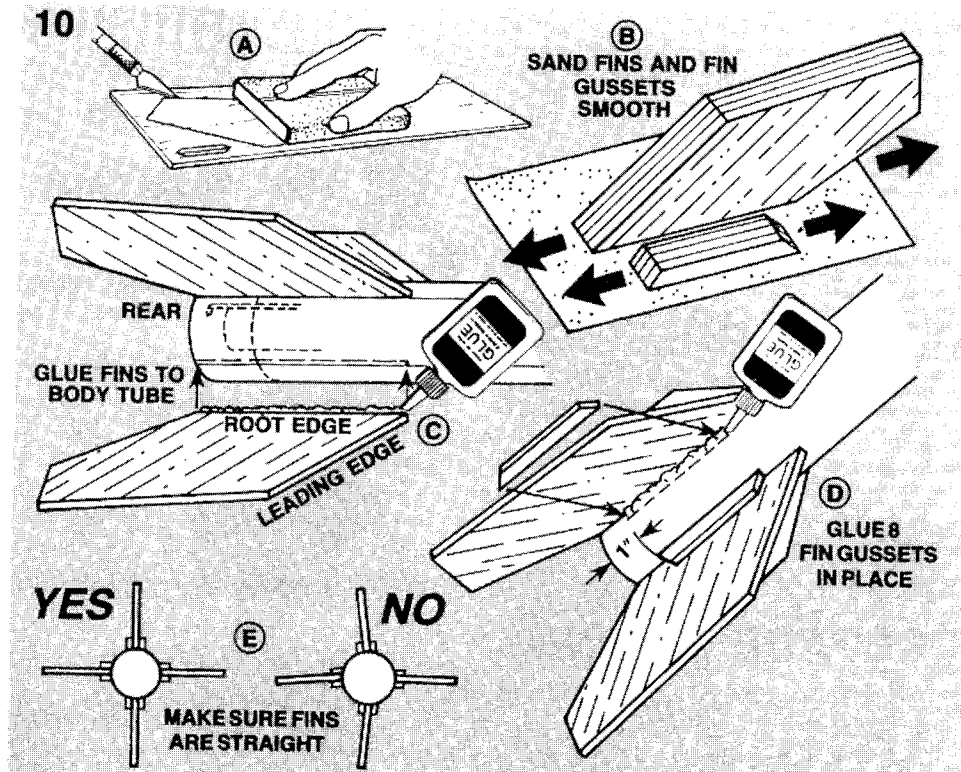

11

- Cut launch lug in half to give two equal pieces, each 1 inch in length.
- Glue one lug on launch lug line even with end of body tube and then glue remaining lug on line next to tube joint as shown.

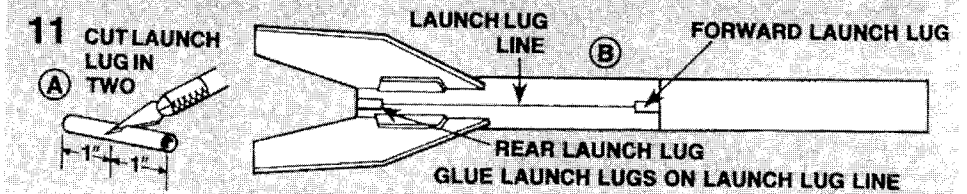

12

- Cut shock cord mount from pattern sheet.
- Crease on dotted lines by folding. Spread glue on section 1 and lay end of shock cord into glue. Fold over and apply glue to back of first section and exposed part of section 2. Lay shock cord as shown and fold mount over again.
- Clamp unit together with fingers until glue sets.
- Apply glue inside front of body tube to cover an area no less than 2 to 3 inches from end. The glue area should be same size as shock cord mount. Press mount firmly into glue as shown. Hold until glue sets.

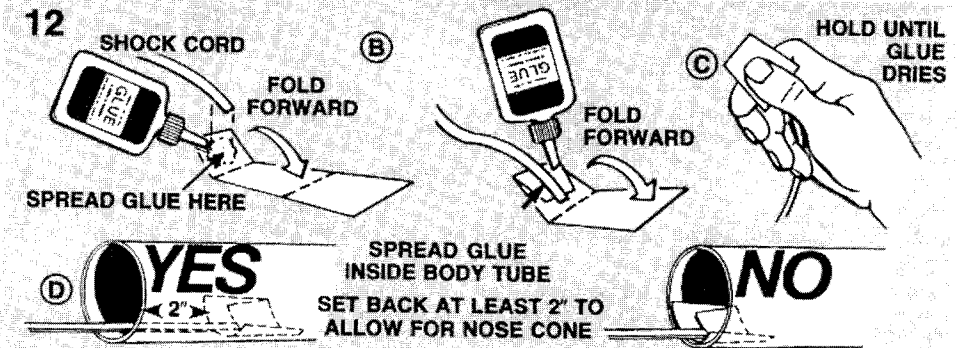

13

- Cut out parachute on edge lines.
- Cut three 35 inch lengths of shroud line.
- Form small loops with shroud line ends and press onto sticky side of tape discs.
- Attach tape discs with line ends to top of parachute as shown.
- Firmly press tape discs into place until both tape discs and parachute material are molded around shroud line loops.
- Pass shroud line loops through eyelet on nose cone. Pass parachute through loop ends and pull lines against the nose cone.
- Tie free end of shock cord to nose cone eyelet.

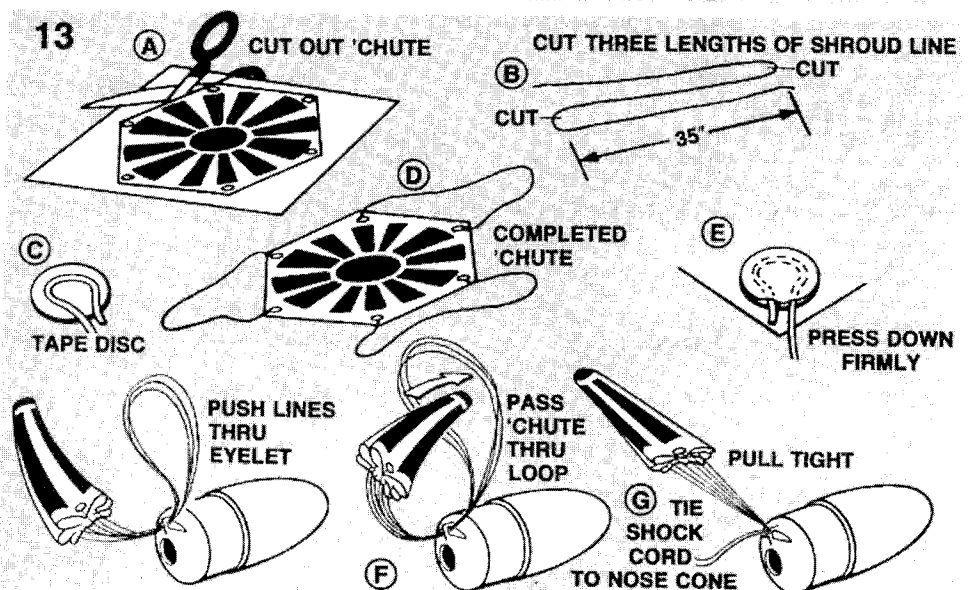

FINISHING YOUR ROCKET

- 1) Fill and Sand Balsa Fins
- 2) Paint Entire Rocket White
- 3) Paint Lower 9" Red
- 4) Paint 1 Fin White
- 5) Apply Decals

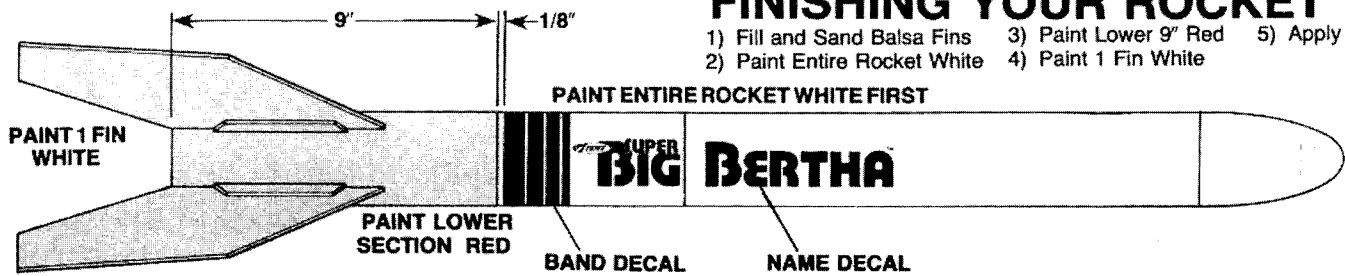

ROCKET PREFLIGHT

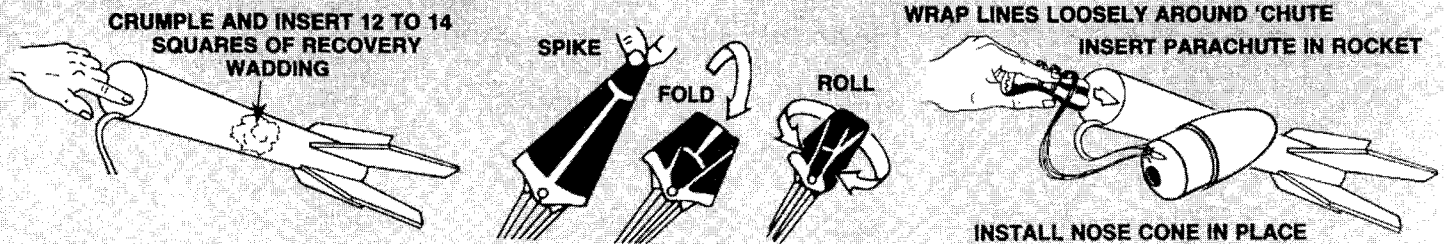

PREPARE ENGINE

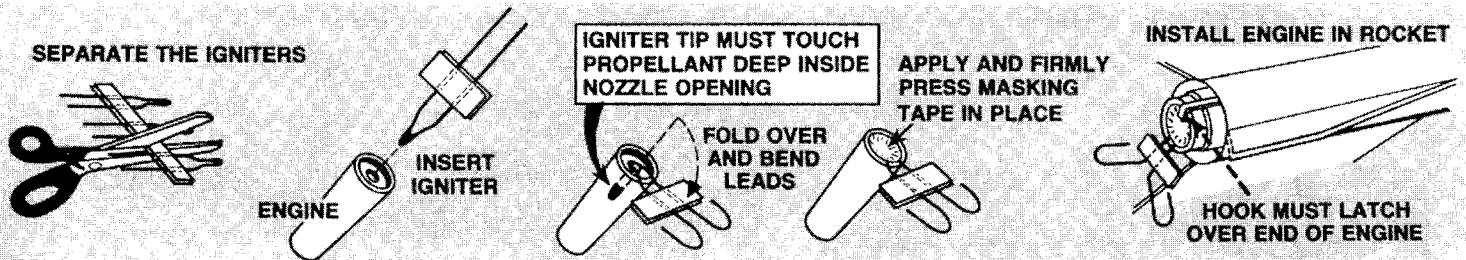

LAUNCH SUPPLIES

To launch your rocket you will need the following items:
 Estes Electrical Launch System and Launch Pad
 —Estes Recovery Wadding (No. 2274)
 —Estes Maxi-Rod No. 2239
 —Recommended Engines: Estes D12-5 ONLY
 Use only Estes products to launch this rocket.

FLYING YOUR ROCKET

Choose a large field away from power lines, tall trees, and low flying aircraft. Try to find a field at least 500 feet square. The larger the launch area, the better your chance of recovering your rocket. Football fields and playgrounds are great.

Launch area must be free of dry weeds and brown grass.

Launch only during calm weather with little or no wind and good visibility.

Don't leave parachute packed more than a minute or so before launch during cold weather, [colder than 40° Fahrenheit (4° Celsius)].

Parachute may be dusted with talcum powder to avoid sticking

MISFIRES

Failure of the model rocket engine to ignite is nearly always caused by incorrect igniter installation. An Estes igniter will function properly even if the coated tip is chipped. However, if the coated tip is not in direct contact with the engine propellant, it will only heat and not ignite the engine.

When an ignition failure occurs, remove the safety key from the launch control system and wait one minute before approaching the rocket. Remove the expended igniter from the engine and install a new one. Be certain the coated tip is in direct contact with the engine propellant, then tape the igniter leads firmly to base of engine as illustrated above. Repeat the countdown and launch procedure.

FOR YOUR SAFETY AND ENJOYMENT

Always follow the NAR-HIA* MODEL ROCKETRY SAFETY CODE while participating in any model rocketry activities.

*National Association of Rocketry-The Hobby Industry of America
 page 4

COUNTDOWN AND LAUNCH

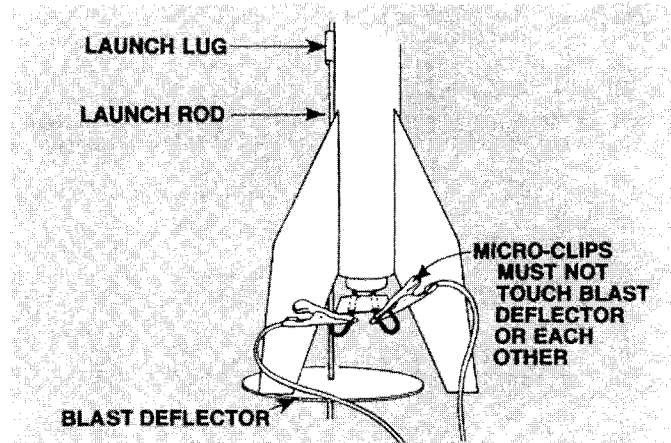

- 10 REMOVE SAFETY KEY to disarm the launch controller.
- 9 Remove safety cap and slide launch lugs over launch rod to place rocket on launch pad. Make sure the rocket slides freely on the launch rod.
- 8 Attach micro-clips to the igniter wires. Arrange the clips so they do not touch each other or the metal blast deflector. Attach clips as close to protective tape on igniter as possible.
- 7 Move back from your rocket as far as launch wire will permit (at least 15 feet).
- 6 INSERT SAFETY KEY to arm the launch controller.
 Give audible countdown 5...4...3...2...1

LAUNCH!!!

PUSH AND HOLD LAUNCH BUTTON UNTIL ENGINE IGNITES

Remove safety key—Replace cap on launch rod.



1295 H Street
Penrose, CO 81240

www.estesrockets.com

SUPER BIG BERTHA™

FLYING MODEL ROCKET KIT

NO. 2165

Congratulations, you have purchased a Classic kit from Estes! We have tried to keep this kit as close to the original 1989 version of the Super Big Bertha™ kit as possible. For your enjoyment we've enclosed the original 1989 instructions. Over the years, several features have been improved and the changes are shown in this document. Use the original instruction as well as this document to build your model.

PARTS AND SUPPLIES

The following items have been updated since the initial release of the Super Big Bertha™ kit:

The engine hook has been updated as shown.

Included with your Super Big Bertha™ kit is a Ready-to-Fly parachute. The shroud line and tape discs are pre-assembled on the RTF parachute and will not come separate in the kit.

Use white or yellow glue to build the Super Big Bertha™ kit.

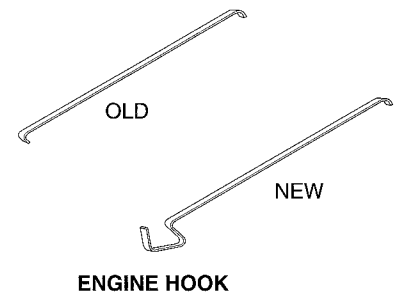

STEP 13. PARACHUTE ATTACHMENT

You have received a Ready-to-Fly parachute in your kit. Disregard steps A thru E in Section 13 of the original instructions.

To attach the Ready-to-Fly parachute to the nose cone, follow Steps F and G.

Use the following in place of the 'PREPARE ENGINE' step on page 4.

PREPARE ENGINE

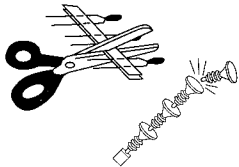

A. Separate igniter and plug

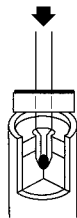

B. Hold engine upright, drop in igniter. Igniter tip must touch propellant. Do NOT bend igniter!

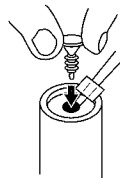

C. Insert igniter plug

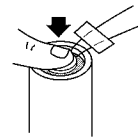

D. Press down firmly.

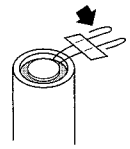

E. Bend igniter wires back and form leads as shown.

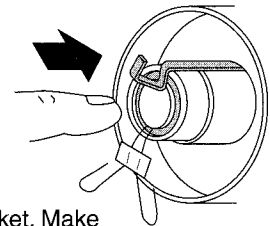

F. Insert engine in rocket. Make sure engine hook locks engine securely in place.

WARNING: FLAMMABLE

Before proceeding read instructions & NAR Safety Code included with engines.

PREPARE YOUR ENGINE ONLY WHEN YOU ARE OUTSIDE AT THE LAUNCH SITE PREPARING TO LAUNCH!
If you do not use your prepared engine, remove the igniter before storing your engine.

See the back of this page for Flying and Launching Instructions, Launch Supplies, and Misfire Procedure.

LAUNCH SUPPLIES

To launch your rocket, you will need the following:

- Launch Pad (Estes Porta-Pad® II)
- Launch Controller (Estes Electron Beam®)
- Recommended Estes Engines: D12-5 only
- Igniters and igniter plugs (included with Estes engines)
- Estes Maxi™ Launch Rod (EST 302244)

Use only Estes products to launch this rocket.

TIPS FOR FLYING YOUR ROCKET

- Choose a large field away from power lines, buildings, tall trees, and low flying aircraft. Try to find a field at least 500 feet (152 meters) square. The larger the launch area, the better your chance of recovering your rocket.
- Launch area must be free of dry weeds and brown grass.
- Launch only during calm weather with little or no wind and good visibility.
- Don't leave parachutes or streamer packed more than a minute or so before launch during cold weather (colder than 40° Fahrenheit [4° Celsius]).
- Always follow the National Association of Rocketry (NAR) MODEL ROCKETRY SAFETY CODE while participating in any model rocketry activities. The safety code is enclosed with this kit.

COUNTDOWN AND LAUNCH

10... Make sure that the safety key is **not** inserted in the launch controller.

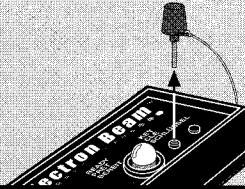

9... Remove the safety cap from the launch rod. Slide the rocket's launch lugs down the launch rod. Make sure rocket slides freely.

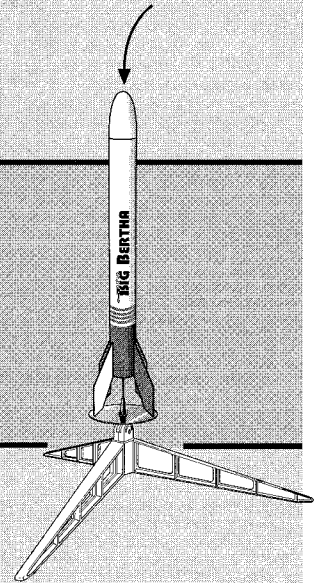

8... Make sure micro-clips are clean. Attach micro-clips on the igniter wire leads as shown. Arrange the clips so they do not touch each other, the launch rod or the metal blast deflector.

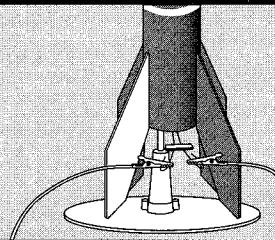

7... Move everyone away from your rocket as far as the launch wire will permit. (At least 15 feet - 5 meters)

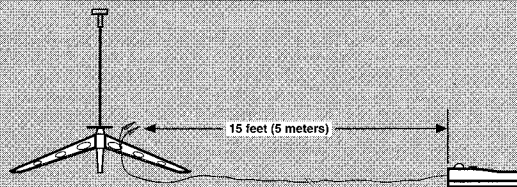

6... Insert safety key. Press the safety key in until bulb glows, hold during the countdown and launch. **NOTE:** The engines can only be ignited when the safety key is held down.

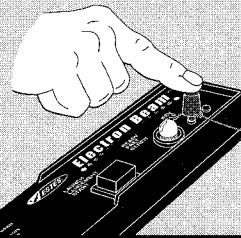

5... Start audible countdown.

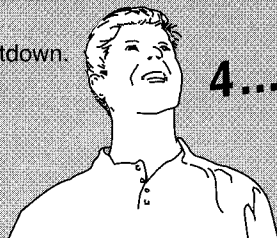

4...3...2...1...

LAUNCH!

While pushing the key down, push launch button until the engine ignites. **IMMEDIATELY REMOVE THE SAFETY KEY FROM THE LAUNCH CONTROLLER. REPLACE THE SAFETY CAP ON THE LAUNCH ROD.**

MISFIRES

When an ignition failure occurs, **remove the safety key** from the launch control system and **wait one minute before approaching the rocket**. Remove the expended igniter from the engine and install a new one. Be certain the coated tip is in direct contact with the engine propellant. Broken or chipped coating will not affect the performance of the igniter. Reinstall the igniter plug as illustrated previously. Repeat the countdown and launch procedure.

11
10
9
8
7
6
5
4
3
2
1
MADE IN USA

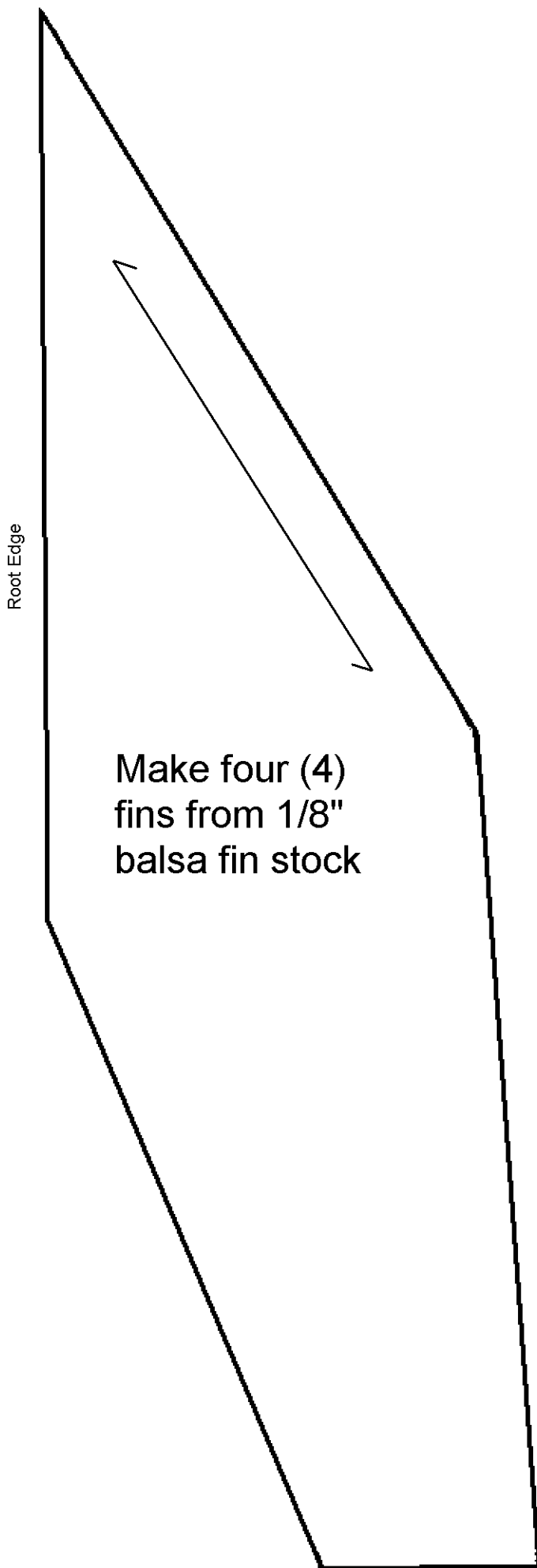

Make eight (8) fin gussets from 1/8" balsa fin stock



ESTES.
SUPER
BIG

BERTHATM

1989/2000
© Centuri Corp.
(02/00) P/N 3734;

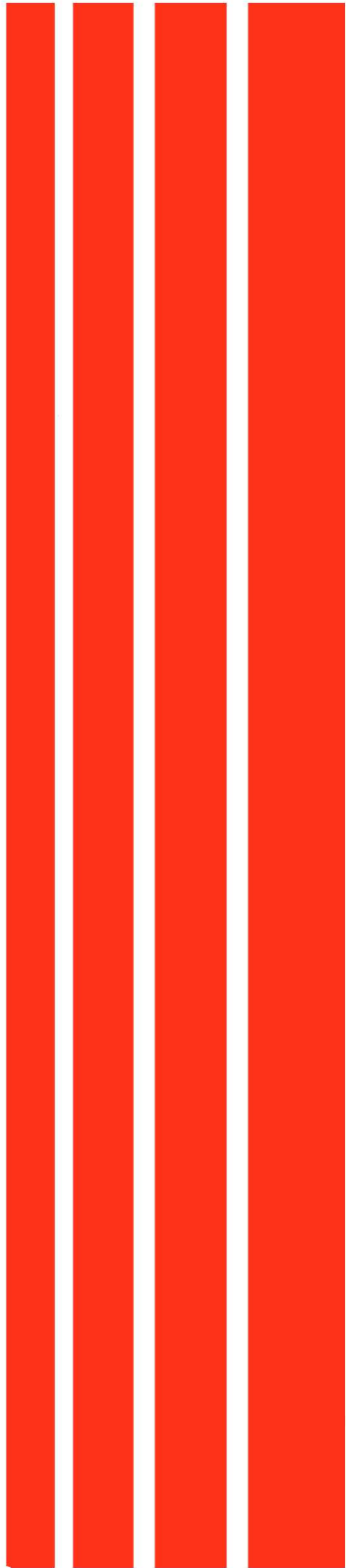

SUPER BIG BERTHA #2165 parts descriptions

BODY TUBES:	BT80, 14.25" long (x2)
ENGINE TUBE:	BT50, 18" long
CENTERING RINGS:	CR5080, 1/16" thick cardboard (x4)
TUBE COUPLER:	TC80, 1" long
NOSE CONE:	PNC80BB (Fat Boy style)
FIN STOCK:	1/8" balsa
PARACHUTE:	18" Plastic
SHOCK CORD:	24" long, 1/4" wide flat elastic
ENGINE BLOCK:	CR2050 (x1), 1/4" wide thick cardboard
LAUNCH LUG:	2" long, 3/16" Maxi-Rod standard lug
ENGINE HOOK:	2.75" standard
RETAINER TUBE:	1/16" thick-walled kraft tube, 2.125" long, slips over

BT50

YELLOW SPACER TUBE:	Dummy motor casing, 24mm (spent D engine equivalent)
---------------------	--