



ESTES INDUSTRIES
1295 H Street
Penrose, CO 81240

(11-97) 84424

EST 2156

BETA
SERIES
SKILL LEVEL 1

© Copyright 1997 Centuri Corp.
All rights reserved.

PROWLER™

FLYING MODEL ROCKET KIT INSTRUCTIONS

MATERIALS REQUIRED:

PENCIL, RULER, HOBBY KNIFE, WHITE OR YELLOW GLUE, 3/4" (19 mm) MASKING TAPE, SANDPAPER, AUTOMOTIVE PRIMER, DARK BLUE GLOSS SPRAY PAINT

ALL GLUED AREAS ARE SHADED IN GRAY

BE SURE TO READ ALL INSTRUCTIONS, TEST FIT ALL PARTS, AND SAND IF NECESSARY BEFORE GLUING.

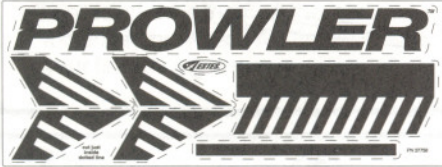

DECAL (1)
37608

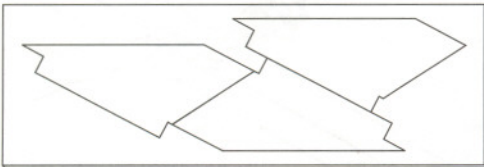

DIE CUT BALSA FIN SHEET (1)
32906



CENTERING RINGS
#2060 (1 CARD)
30128



RED TUBE COUPLERS
KJT 60C (2)
30176-5

SLOTTED BODY TUBE
#BT-60 x 12 (1)
31189

BLACK RETAINER
RING KERH 20 (1)
30170-3

WHITE ENGINE
MOUNT TUBE
#BT-20 (1) 30329



ENGINE HOOK
EH-2A (1)
35021



LAUNCH LUGS LL2A (2)
38175

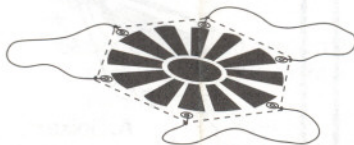

ASSEMBLED PARACHUTE - 24 (1)
35803

NOSE CONE 60NA
72057

ADAPTER
NOT USED

BODY TUBES
#BT-60 x 12 (2)
30397

SHOCK CORD 1/4 x 36
38382

PARTS LAYOUT

1.

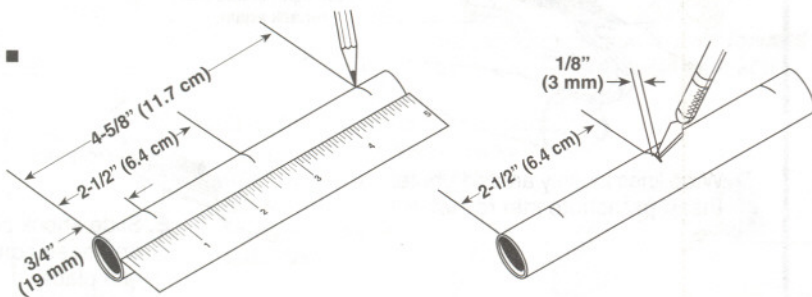

A. Mark the white engine mount tube at 3/4" (19 mm), 2-1/2" (6.4 cm), and at 4-5/8" (11.7 cm).

B. Use a hobby knife to make a 1/8" (3 mm) wide slit at the 2-1/2" (6.4 cm) mark **only**.

2.

A. Insert the engine hook into the slit as shown.

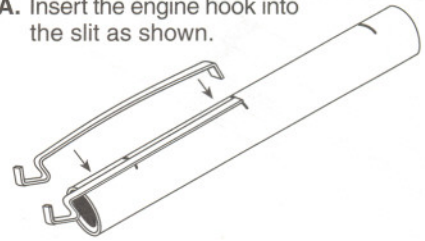

B. Apply the 3/4" the bla the tub the ma the eng

3.

A. Use a hobby knife to carefully cut fins out of sheet. (Always cut away from other fins to avoid damage.) Be sure cuts go all the way through the balsa, then remove fins.

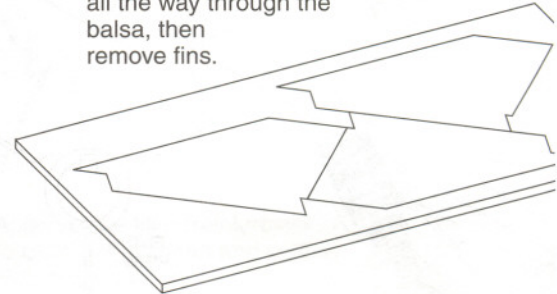

F. Once rin apply glu of rings, and let g

D. Test fit all fins to make su the centering rings and contact the engine mo necessary for a proper

4.

3/4" (1.9 cm)

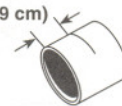

A. Mark the two red tube couplers at 3/4" (1.9 cm).

B. Test fit oc of glue ir slots) of one end

FRONT OF SLOTTED
BODY TUBE

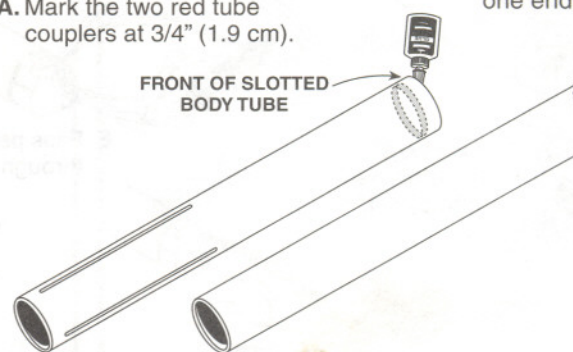

in line of glue just above
 19 mm) mark, then slide
 engine retainer ring down
 and through the glue to
 This will secure
 the hook.

4" (19 mm)
 MARK

are in place,
 around both sides
 smooth with finger,
 dry thoroughly.

C. Use a hobby knife to carefully
 remove the centering rings
 from their card.

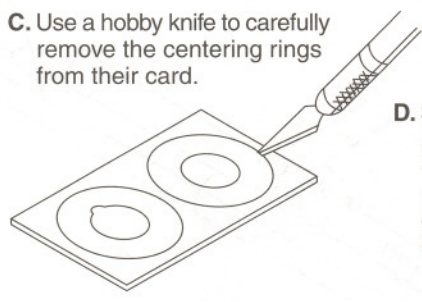

D. Slide the notched centering ring
 (with notch over the engine hook)
 onto the rear of the engine
 mount tube until it fully
 contacts the black
 retainer ring.

NOTCH

MARK

E. Slide the remaining
 centering ring over
 the front of the
 engine mount
 tube to the 4-5/8"
 (11.7 cm) mark.

NOTE: YOU MAY NEED
 TO SAND RINGS FOR
 PROPER FIT.

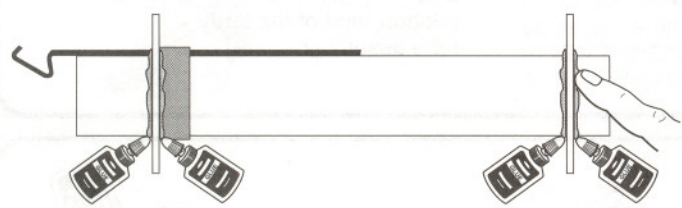

also



B. Keep a stick of scrap balsa
 to use as a glue applicator.

C. Lay sandpaper, rough side up, on table. Stack fins
 together and lightly sand the edges smooth and
 flat. DO NOT SAND AWAY TABS ON
 ROOT EDGES. NOTE: Identify
 the root, leading, and
 trailing edges of your fins.

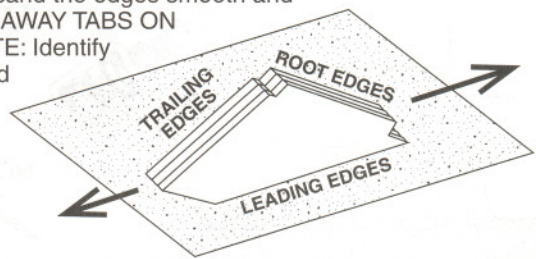

NOTE HOW FIN FITS
 IN FRONT OF
 ENGINE RETAINER RING

DO NOT
 GLUE YET!

they fit between
 that the tabs
 at tube. Sand as
 t.

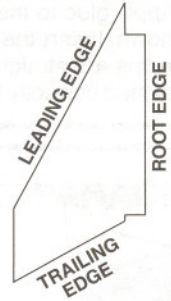
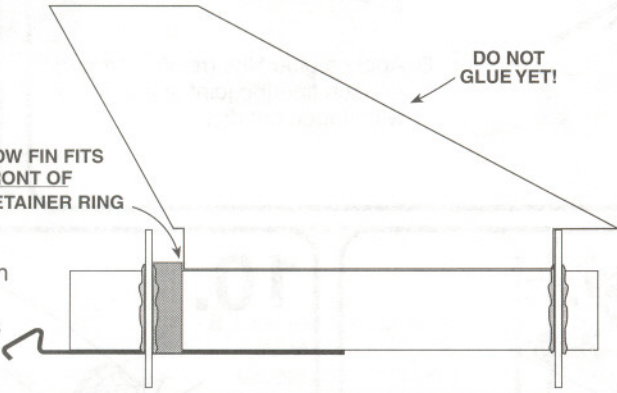

LEADING EDGE

E. Sand the leading
 and trailing fin
 edges round.

TRAILING EDGE

plers, then apply a small amount
 side the FRONT (end without
 the slotted body tube and inside
 of a non-slotted tube.

C. Use a twisting motion to insert a red
 tube coupler into each tube up to their
 3/4" (1.9 cm) marks. Let glue dry.

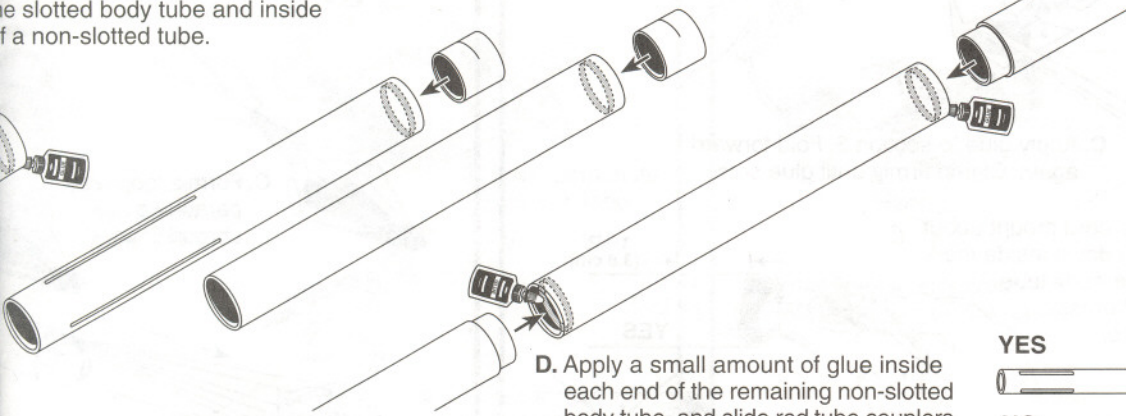

E. While glue is still wet, roll the joined
 tubes on a flat surface. Allow to dry.
 (This will ensure the body of your
 rocket is straight.)



YES



NO



D. Apply a small amount of glue inside
 each end of the remaining non-slotted
 body tube, and slide red tube couplers
 into each end until the tubes are
 perfectly joined.

5.

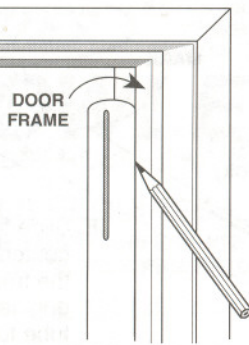

DOOR FRAME

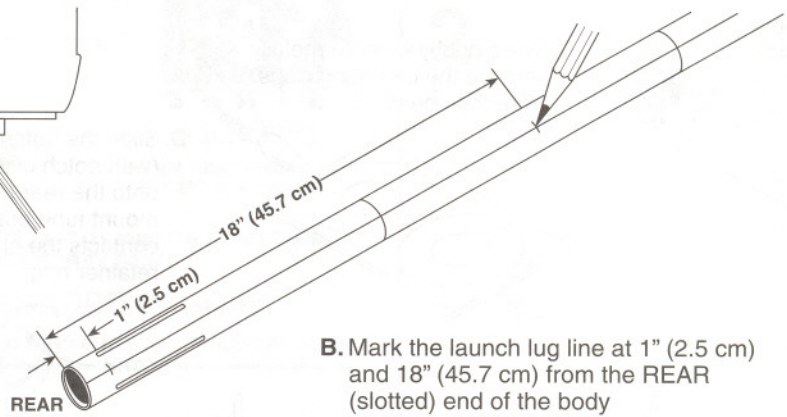
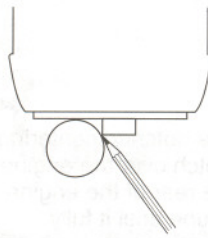

REAR

A. Use a door frame to lightly draw a straight line down the length of the body tube assembly between two fin slots. This is your launch lug line.

B. Mark the launch lug line at 1" (2.5 cm) and 18" (45.7 cm) from the REAR (slotted) end of the body tube assembly.

6.

A.

7.

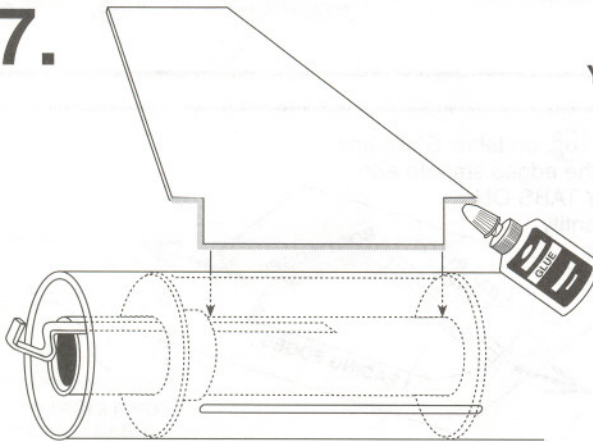

YES

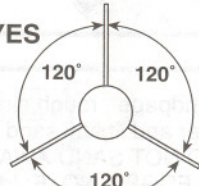

NO

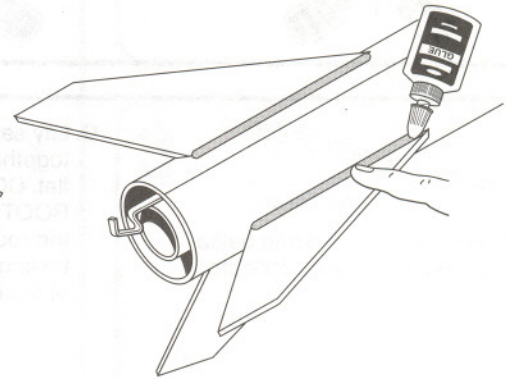

A. Test fit the fins into the slots. Apply glue to the tab on each fin and along the fin root as shown. Insert the fins into slots. Check alignment to make sure fins are straight. Let glue set. REMEMBER: Fins must be attached correctly for stable flight.

B. Apply a glue fillet (reinforcement) to each fin/tube joint and smooth with finger. Let dry.

8.

A.

9.

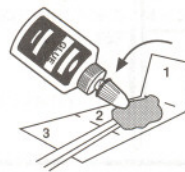
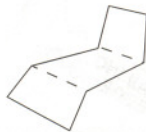
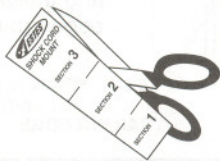

A. Cut out shock cord mount below along solid lines. Crease dotted lines.

B. Spread glue on section 2 and lay shock cord into glue at a slight angle as shown. Fold forward.

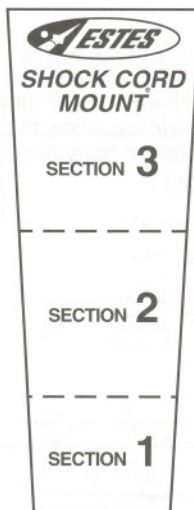

CUT OUT

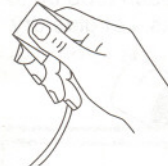

C. Apply glue to section 3. Fold forward again. Clamp firmly until glue sets.

D. Glue the shock cord mount about 1-1/2" (3.8 cm) down inside the front end of the body tube assembly, and press firmly into place. Let dry.

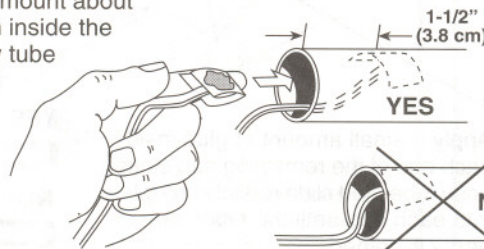

YES

1-1/2" (3.8 cm)

NO

10.

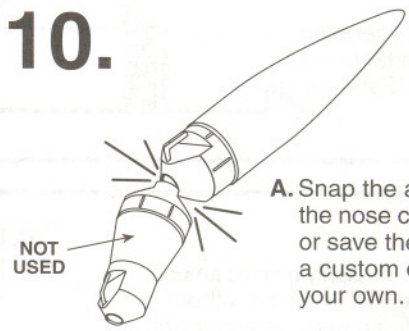

A. Snap the adapter onto the nose cone or save the adapter for a custom design of your own.

NOT USED

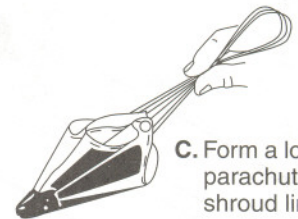

C. Form a loop with parachute shroud lines.

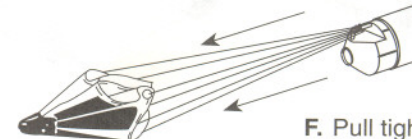

F. Pull tight

ng your wood stick, apply
e inside the body tube near
front of the slots as shown.

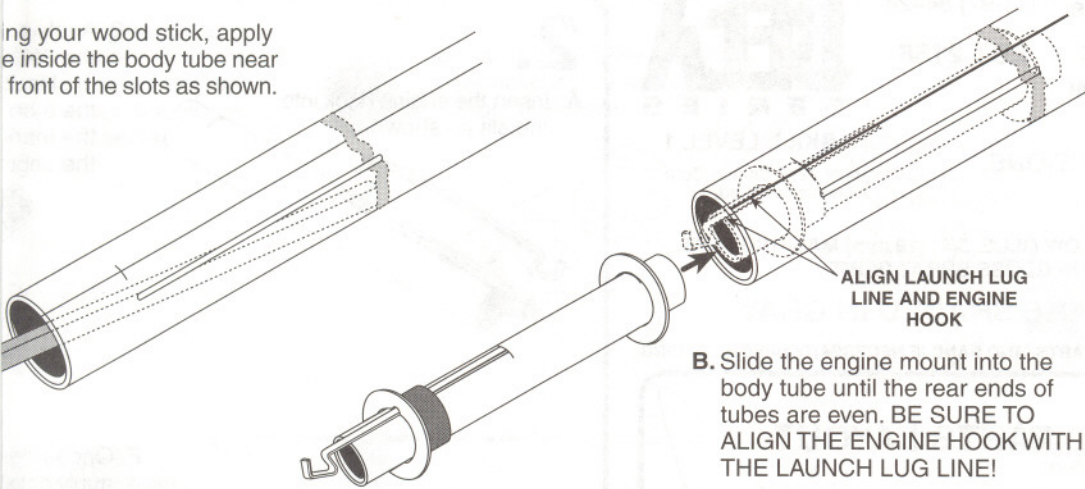

B. Slide the engine mount into the body tube until the rear ends of tubes are even. **BE SURE TO ALIGN THE ENGINE HOOK WITH THE LAUNCH LUG LINE!**

C. Apply a glue fillet (reinforcement) around the joint between the body tube and rear centering ring to reinforce it.

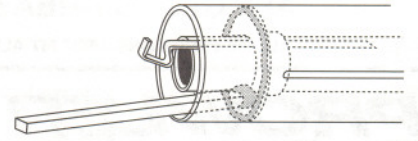

Apply glue to the launch lugs as
shown and apply lugs in front of
marks. Make sure the lugs are
perfectly aligned before glue sets.

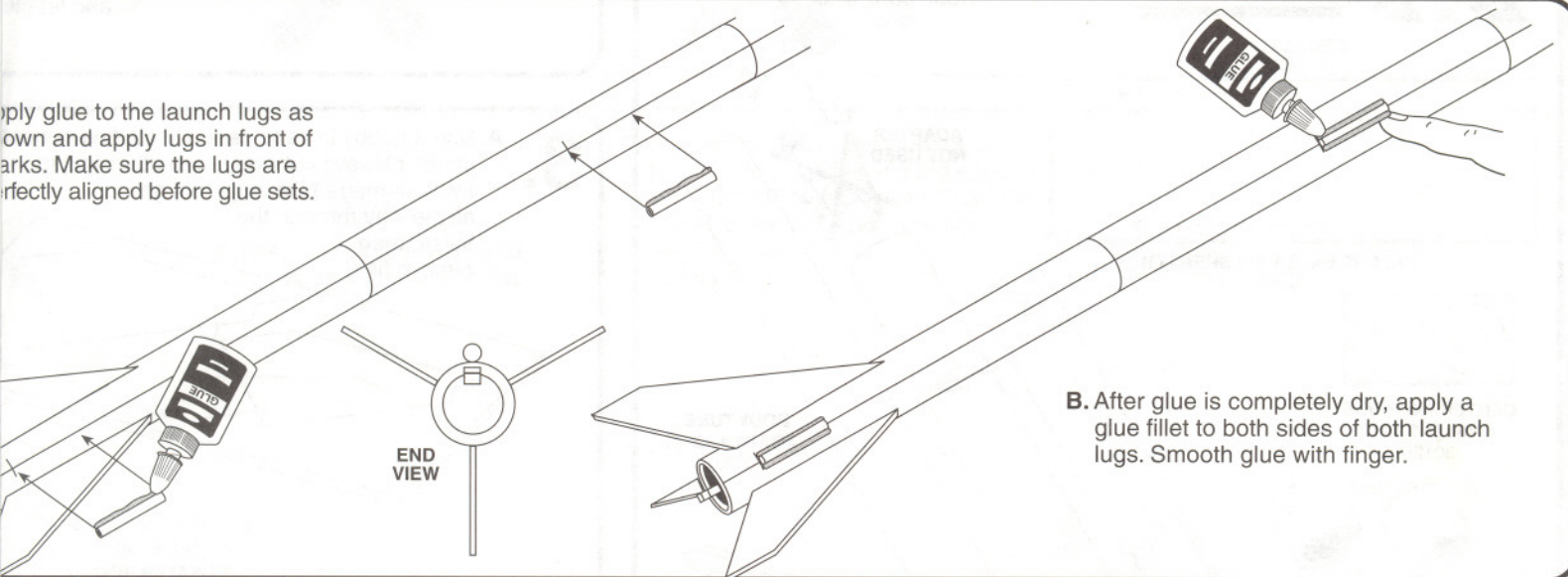

B. After glue is completely dry, apply a glue fillet to both sides of both launch lugs. Smooth glue with finger.

r off
discard
ter for
of

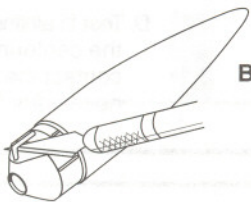

B. Use your hobby knife to carefully remove any excess plastic (flash) from the nose cone. **BE CAREFUL NOT TO CUT OFF EYELET.**

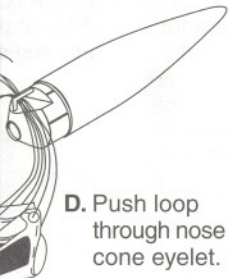

D. Push loop through nose cone eyelet.

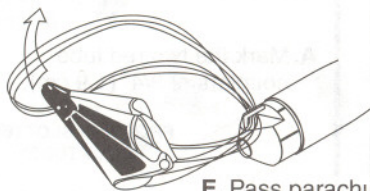

E. Pass parachute through loop.

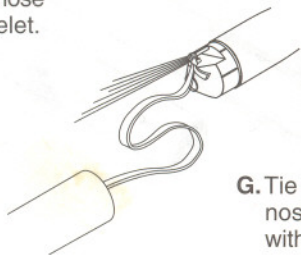

G. Tie shock cord to nose cone eyelet with a double knot.

11. PACKING PARACHUTE



A. Spike.

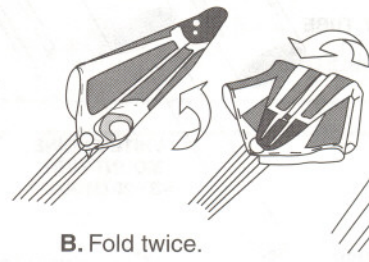

B. Fold twice.

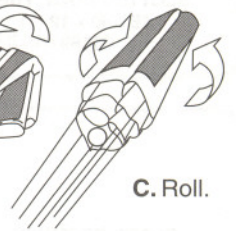

C. Roll.

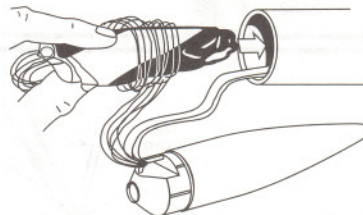

D. Wrap lines loosely around 'chute. Insert parachute into rocket.

Parachute should slide easily into body tube. If fit is too tight, unfold and repack again.

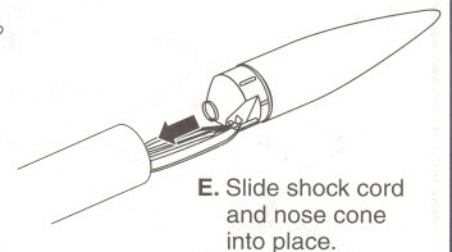

E. Slide shock cord and nose cone into place.

Do not forget to pack recovery wadding in the rocket before flying - see Step 13

12. FINISHING YOUR ROCKET

- A. Use automotive primer to smooth and fill balsa fins and body tube. If necessary, sand with 400 grit sandpaper and reapply primer until a smooth finish is achieved.
- B. Paint the entire rocket a dark glossy blue.

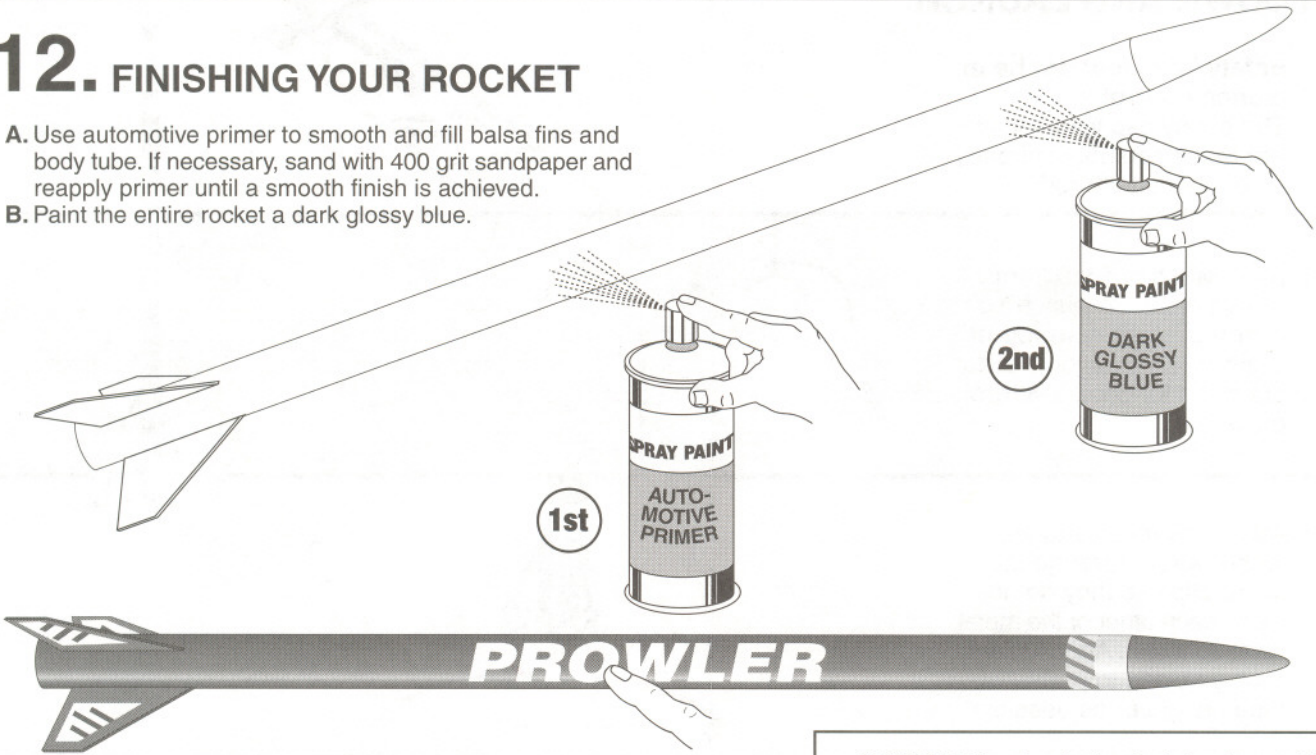

- C. When paint is thoroughly dry, carefully cut out one decal at a time just inside the dotted lines. Remove from backing paper and position on rocket as shown on box.
- D. Once in position, rub decal with finger to remove air bubbles and secure decal to rocket.

CAUTION: The glow-in-the-dark decals provided in this model rocket kit are intended for display purposes ONLY! DO NOT LAUNCH IN THE DARK! You could be seriously injured by tripping over or running into unseen objects during recovery!

13. FLIGHT PREPARATION

PARACHUTE PREPARATION

- A. Insert four squares of loosely crumpled recovery wadding into rocket body tube. Repack chute and nose cone.



ENGINE PREPARATION

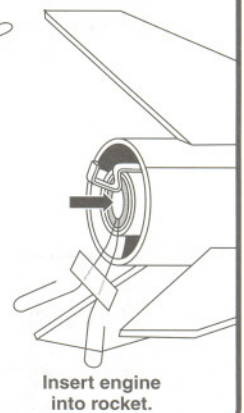
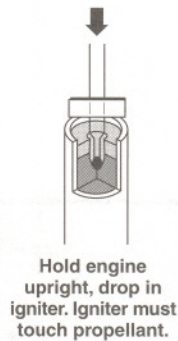
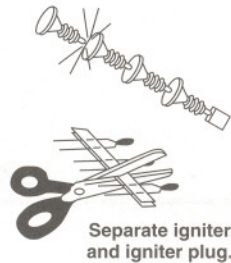

LAUNCH SUPPLIES

To launch your rocket, you will need the following:

- Launch Pad (Estes Porta-Pad® II)
- Launch Controller (Estes Electron Beam®)
- Recommended Estes Engines: B4-2, B6-2, C5-3 or C6-3.

Use a B6-2 for your first flight to become familiar with your rocket's flight pattern. Use only Estes products to launch this rocket.

PROJECTED ALTITUDES

ENGINE	FEET	METERS
B4-2	105	32
B6-2	120	37
C5-3	360	110
C6-3	334	102

TIPS FOR FLYING YOUR ROCKET

- Choose a large field away from power lines, buildings, tall trees, and low flying aircraft. Try to find a field at least 250 feet (76 meters) square. The larger the launch area, the better your chance of recovering your rocket.
- Launch area must be free of dry weeds and brown grass.
- Launch only during calm weather with little or no wind and good visibility.
- Don't leave parachutes or streamer packed more than a minute or so before launch during cold weather (colder than 40° Fahrenheit [4° Celsius]).
- Always follow the National Association of Rocketry (NAR) MODEL ROCKETRY SAFETY CODE while participating in any model rocketry activities. The safety code is enclosed with this kit.

COUNTDOWN AND LAUNCH

- 10...** Safety key must not be in launch controller.
The safety cap with safety key attached should already be on the launch rod.

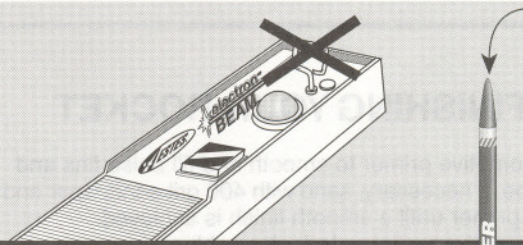

- 9...** Remove safety cap from launch rod, slide launch lugs over rod. Make sure rocket slides freely and micro-clips are clean for good electrical contact.

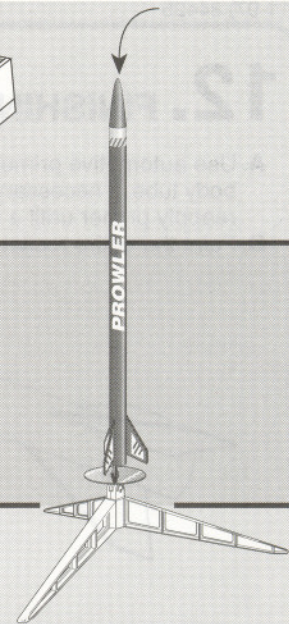
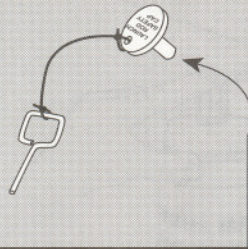

- 8...** Attach micro-clips to the igniter wires. Arrange the micro-clips so they do not touch each other or the metal blast deflector. Attach micro-clips as close to protective tape on igniter as possible.

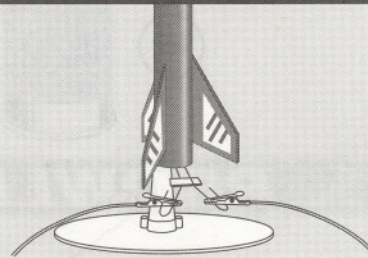

- 7...** Move everyone back from your rocket as far as launch wire will permit (at least 15 feet - 5 meters).

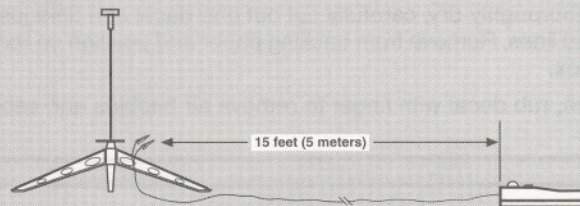

- 6...** Insert safety key to arm the launch controller.

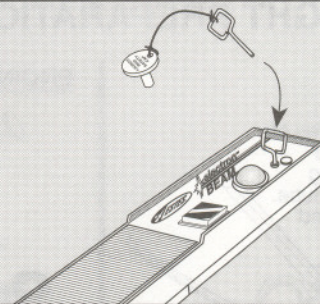

- 5...** Start audible countdown.

4...3...2...1.....

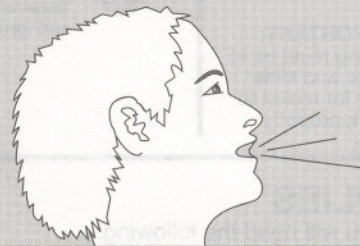

LAUNCH!

Push and hold button until engine ignites.

For safety, immediately remove safety key from launch controller and replace safety cap on launch rod.

MISFIRES

When an ignition failure occurs, **remove the safety key** from the launch control system and **wait one minute before approaching the rocket**. Remove the expended igniter from the engine and install a new one. Be certain the coated tip is in direct contact with the engine propellant. Broken or chipped coating will not affect the performance of the igniter. Reinstall the igniter plug as illustrated previously. Repeat the countdown and launch procedure.



**Liberty
National
Bank**

of Northern Kentucky

MAIN OFFICES

3414 DIXIE HIGHWAY
ERLANGER KY 41017
727-7200

7000 DIXIE HIGHWAY
FLORENCE KY 41042
727-7330

34 N. FORT THOMAS AVENUE
FORT THOMAS KY 41075
727-7300

THIRTEEN BRANCHES TO SERVE YOU

