

# NATIONAL AEROSPACE PLANE (NASP)

FLYING MODEL ROCKET KIT  
#2037



## ASSEMBLY TIP

Read all instructions before beginning work on your model. Make sure you have all parts and supplies. Test-fit all parts together before applying any glue. If any parts don't fit properly, sand as required for precision assembly.

## PARTS AND SUPPLIES

Locate the parts shown below and lay them out on the table in front of you. In addition to the parts included in the kit you will also need:

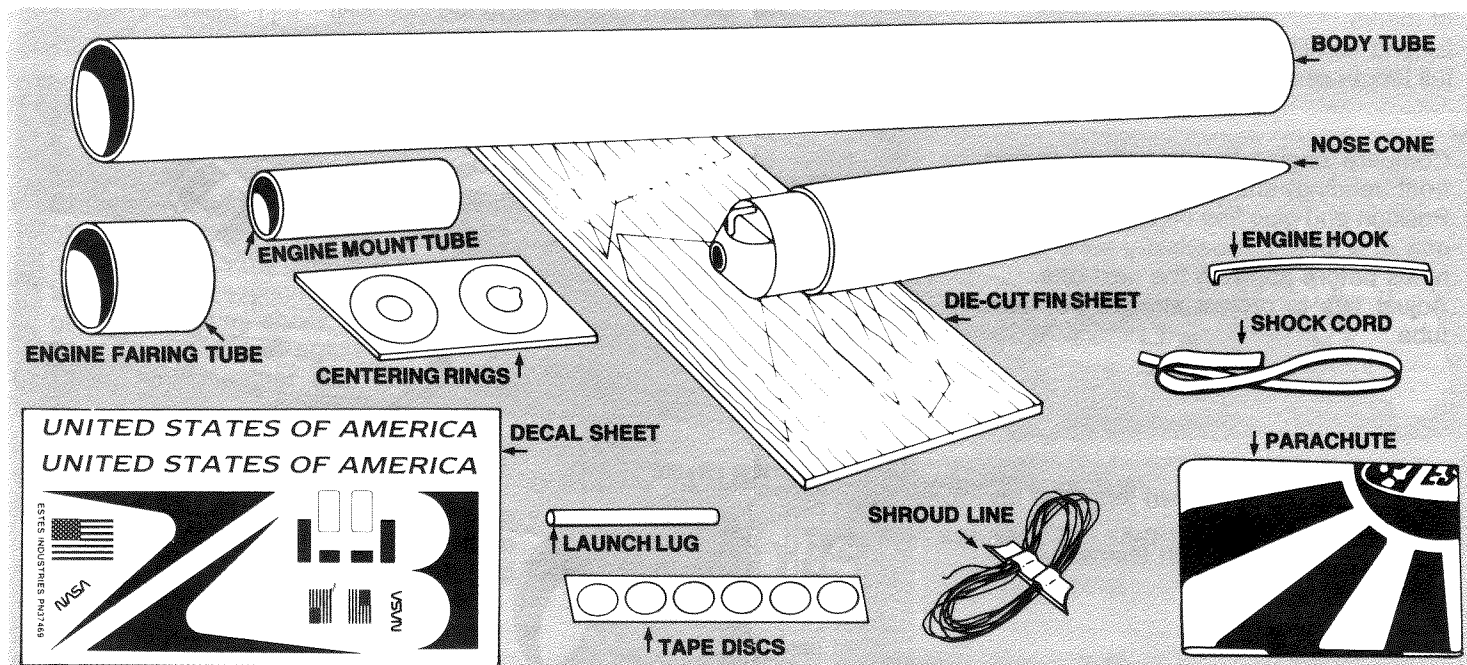
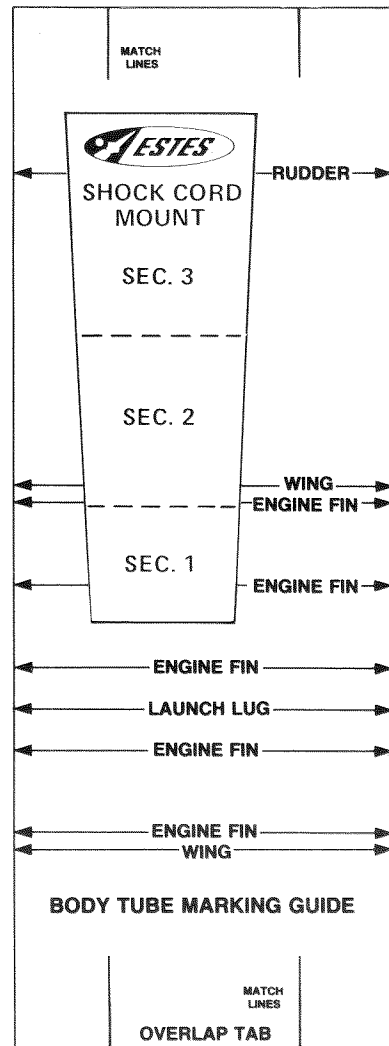
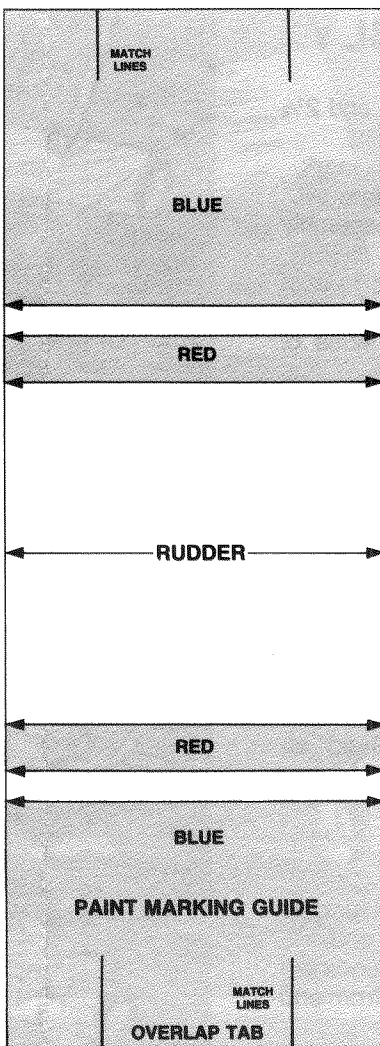
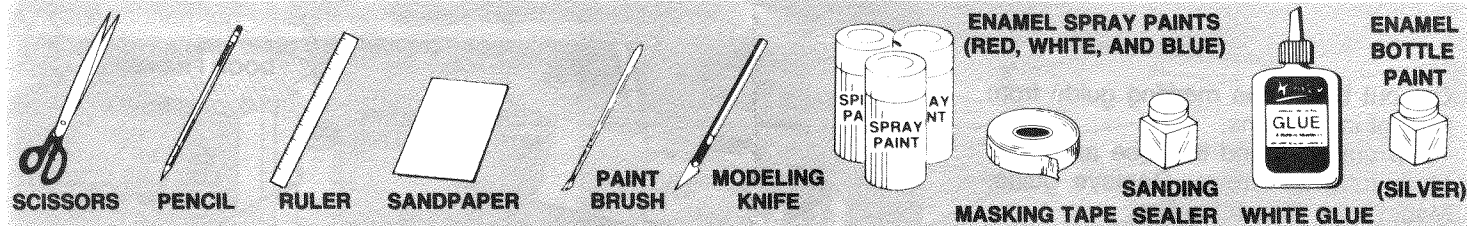

# ROCKET ASSEMBLY

**1.**

- Mark engine mount tube 1 inch and 2½ inches from one end.
- Cut 1/8 inch long slit at 2½ inch mark.
- Insert one end of engine hook into slit.
- Wrap masking tape around assembly twice at 1 inch mark.
- Slide slotted adapter ring onto rear of tube and up to masking tape. Slot fits over engine hook. Glue both sides of ring/tube joint.
- Slide remaining ring over front of tube and down to end of engine hook. Glue both sides of tube joint. Set assembly aside to dry.

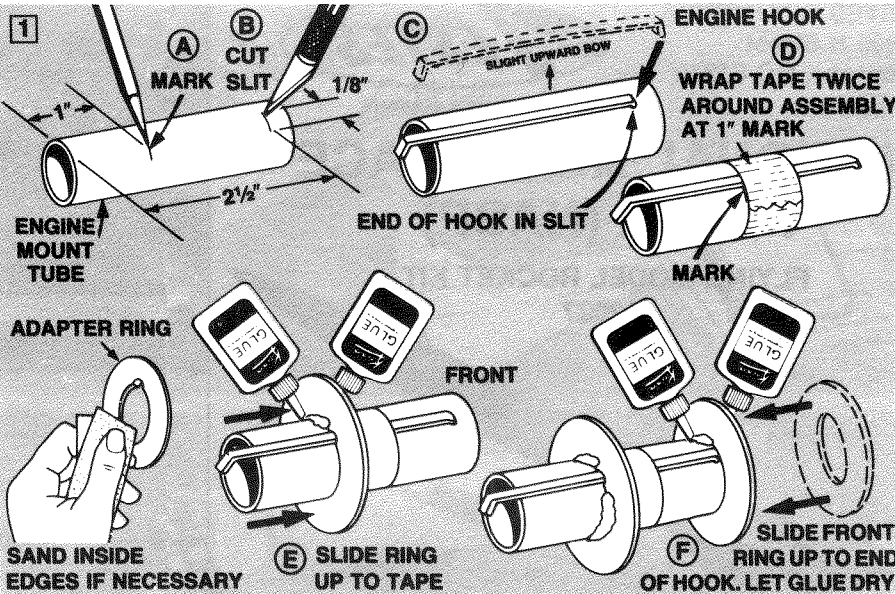

**2.**

- Fine-sand die-cut sheet. Carefully remove wings, engine fins, and rudder by freeing edges with sharp knife.
- Stack alike parts together. Sand all edges smooth.

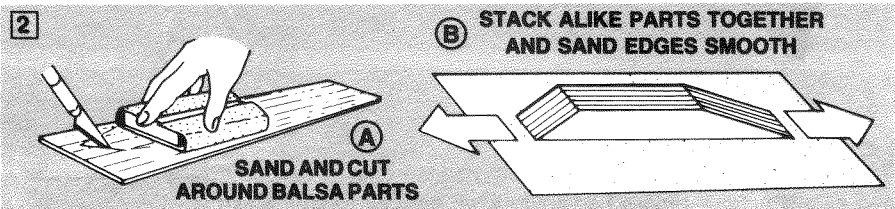

**3.**

- Using a piece of scrap balsa, smear glue inside body tube 2 inches from end.
- Push engine mount in until tube ends are even. Engine hook must extend from end of body tube.

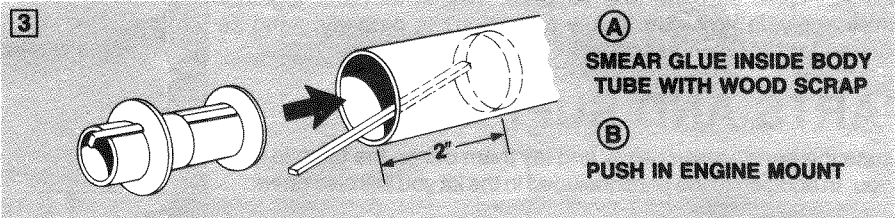

**4.**

- Cut out body tube marking guide from front of instructions.
- Wrap guide around the tube and tape. Mark tube at arrows. Remove guide. Mark LL for launch lug line.
- Draw straight lines connecting each pair of marks.
- Extend launch lug line and rudder line full length of tube.

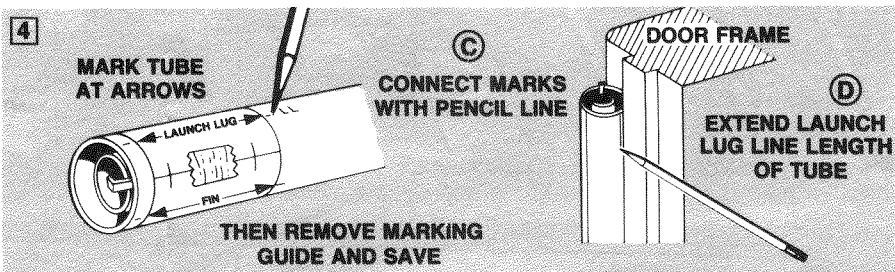

**5.**

- Compare engine fins to pattern to find front (leading) and gluing (root) edges.
- Position and glue fins on alignment lines one at a time. Let each dry several minutes before applying the next one.
- Adjust fins to project straight out from tube.

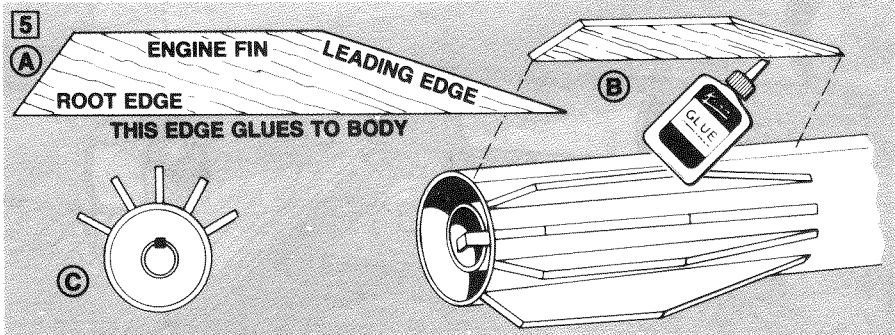

**6.**

- Draw a straight line down length of engine fairing tube.
- Cut tube along line with sharp knife or scissors.

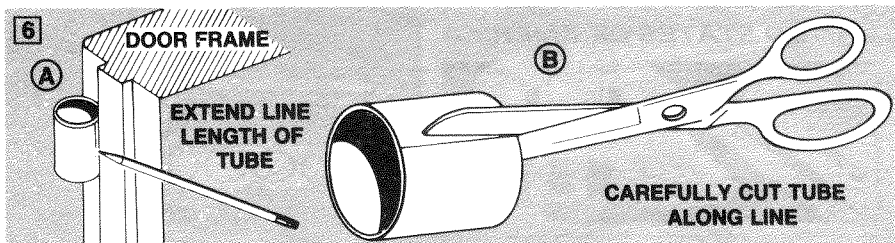

- 7.**
- Apply glue to top edges of engine fins.
  - Position and glue fairing tube to fins. Hold fairing until glue sets.
  - When glue has dried trim excess tube away from fins.

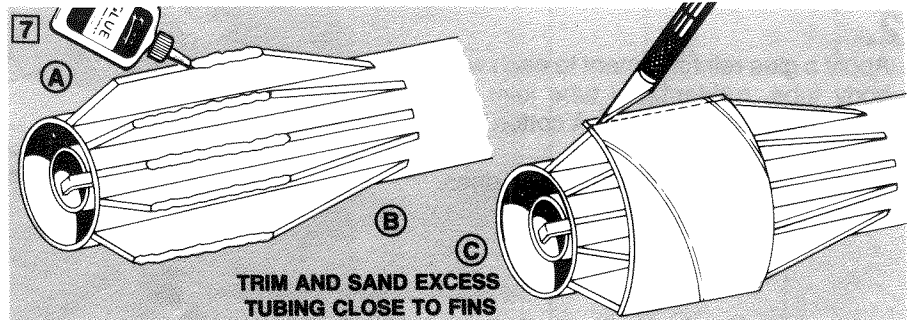

- 8.**
- Mark wing alignment lines 1/2 inch from rear of body tube.
  - Compare wing and rudder to pattern to find front (leading) and gluing (root) edges.
  - Position and glue wings and rudder on alignment lines one at a time. Let each dry several minutes before applying the next one.
  - Adjust wings and rudder to project straight out from tube
- WINGS AND RUDDER MUST BE ATTACHED CORRECTLY FOR STABLE FLIGHT!**

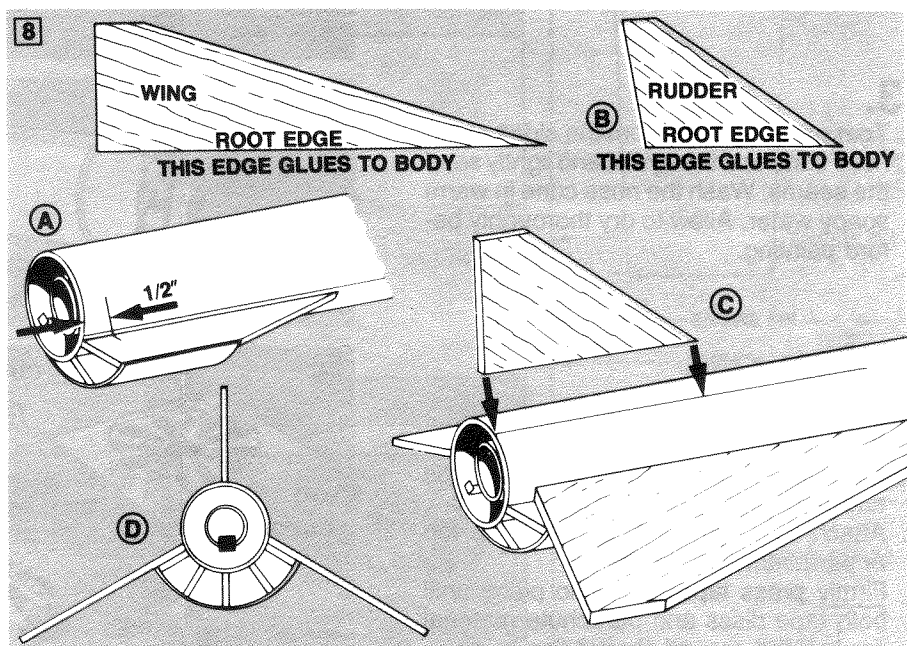

- 9.**
- Glue launch lug straight on launch lug line with its rear edge 8 inches from rear of tube.
  - Make sure launch lug runs straight along the tube.

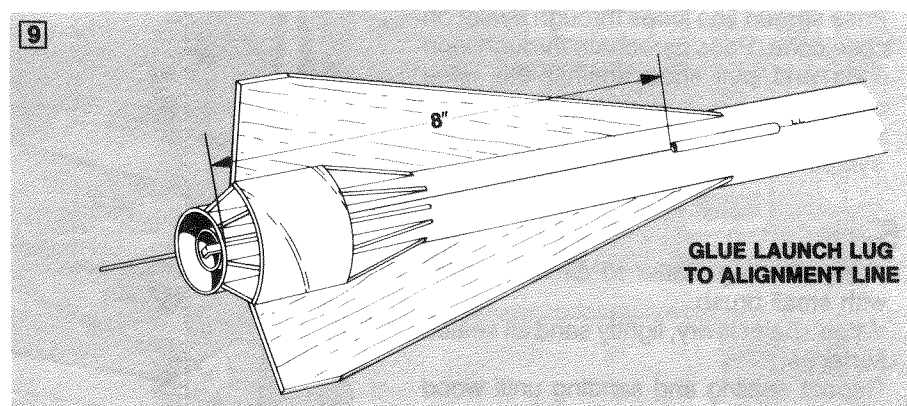

- 10.**
- Cut shock cord mount from body tube marking guide.
  - Crease on dotted lines by folding. Spread glue on section 1 and lay end of shock cord into glue. Fold over and apply glue to back of first section and exposed part of section 2. Lay shock cord as shown and fold mount over again.
  - Clamp unit together with fingers until glue sets.

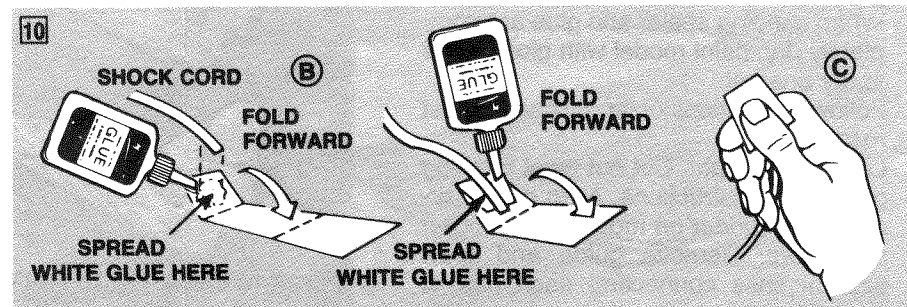

- 11.**
- Apply glue to inside of front of body tube to cover an area no less than 1 inch to 2 inches from end. The glued area should be same size as shock cord mount.
  - Push mount firmly into glue as shown
  - Hold until glue sets.

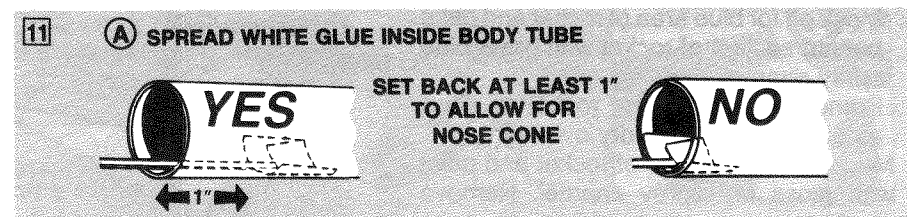

## 12.

- A. Apply a glue reinforcement to each wing/body tube, rudder/body tube joint, and engine fin/body tube joint. A cotton swab may be helpful for this task.
- B. Support rocket as shown until glue dries.

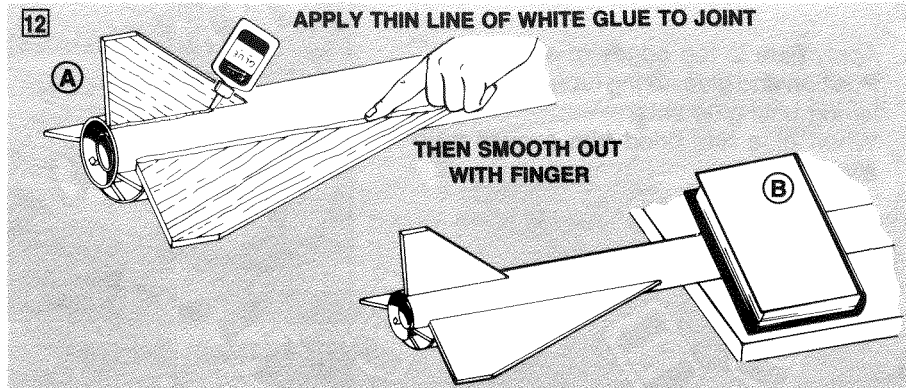

## 13.

- A. Trim excess plastic from the sides of the nose cone and the eyelet and lightly sand the seams. Wash the nose cone in warm soapy water. Allow to dry thoroughly before painting.

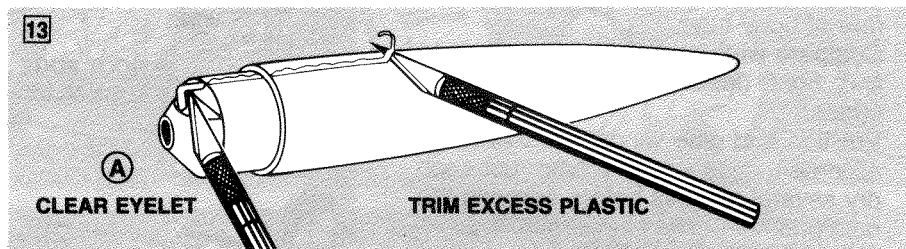

## 14.

- A. Cut out parachute on edge lines.
- B. Cut three 23 inch lengths of shroud line.
- C. Form small loops with shroud line ends and press onto sticky side of tape discs.
- D. Attach tape discs with line ends to top of parachute as shown.
- E. Firmly press tape discs into place until both tape discs and parachute material are molded around shroud line loops.
- F. Pass shroud line loops through eyelet on nose cone. Pass parachute through loop ends and pull lines against the nose cone.
- G. Tie free end of shock cord to nose cone eyelet.

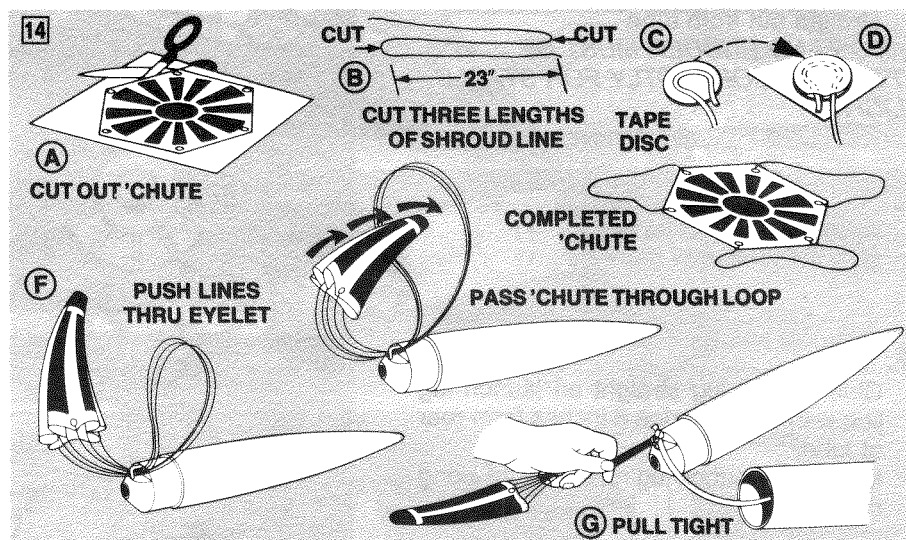

## 15.

- A. Apply sanding sealer to all wood parts with small brush.
- B. When sealer is dry, lightly sand all sealed surfaces.
- C. Repeat sealing and sanding until wood grain is filled and smooth.
- D. When sanding sealer and glue are completely dry, paint model with gloss white spray enamel.
- E. Follow instructions on spray can for best results.
- F. Let dry overnight. Cut out paint marking guide from instructions. Align rudder arrows with rudder on model. Mark rocket at arrows. Remove guide and draw straight lines connecting each pair of marks.
- G. Mask off for blue area of rocket and paint bottom section of rocket with gloss blue spray enamel.
- H. Remove masking from rocket as soon as paint has set. Let dry overnight.
- I. Mask off for red area of rocket and paint with gloss red spray enamel. Remove masking as soon as paint has set.

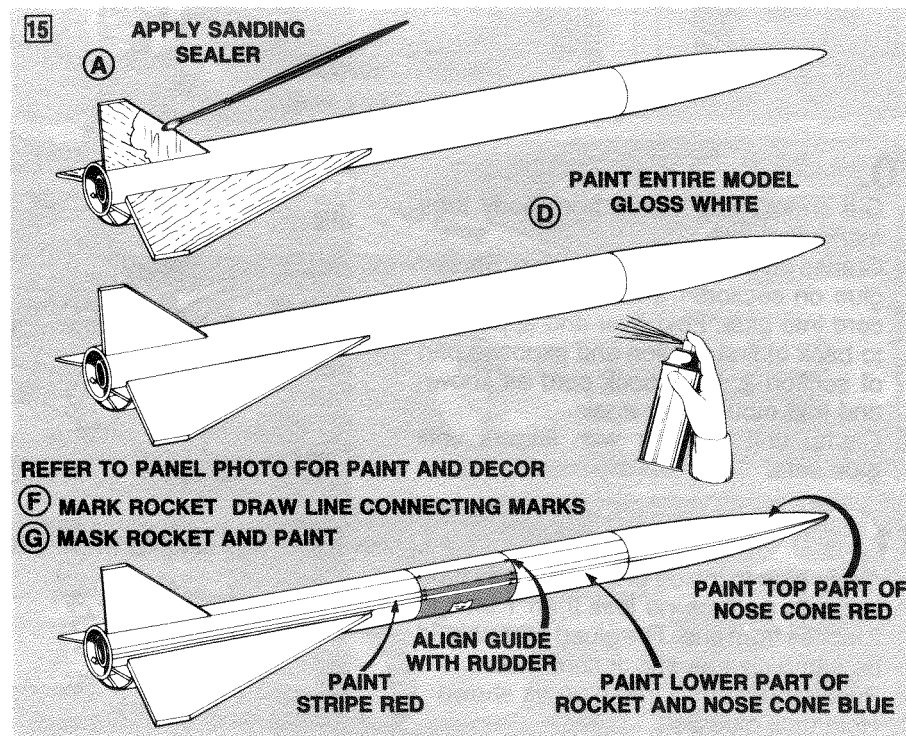

# ROCKET PREFLIGHT

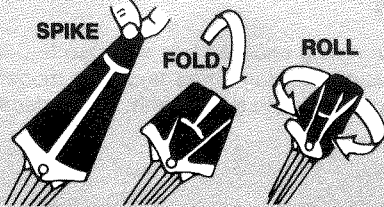
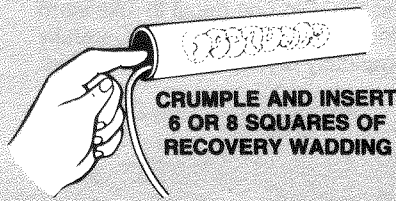

**WRAP LINES LOOSELY  
AROUND 'CHUTE**

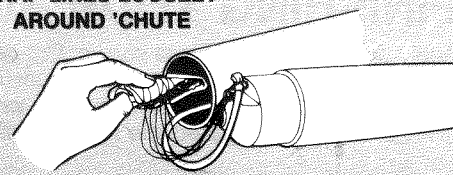

**INSERT PARACHUTE IN ROCKET  
INSTALL NOSE CONE IN PLACE**

# PREPARE ENGINE

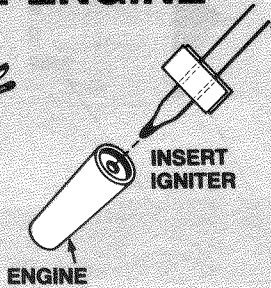
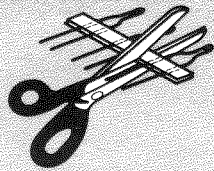

**IGNITER TIP MUST TOUCH  
PROPELLANT DEEP INSIDE  
NOZZLE OPENING**

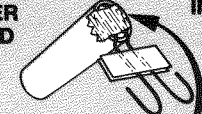
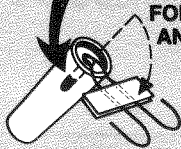

**INSTALL ENGINE  
IN ROCKET**

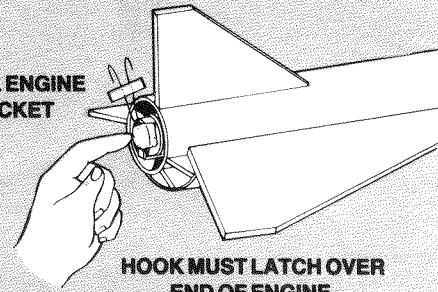

# LAUNCH SUPPLIES

To launch your rocket you will need the following items:

- An Estes model rocket launching system
- Estes Recovery Wadding No. 2274
- Recommended Estes Engines: A8-3 (first flight), B4-4, B6-4, B8-5, or C6-5.

Use B4-4 engine for your first flight to become familiar with your rocket's flight pattern.

*Use only Estes products with this rocket.*

# FLYING YOUR ROCKET

Choose a large field away from power lines, tall trees, and low flying aircraft. Try to find a field at least 250 feet square. The larger the launch area, the better your chance of recovering your rocket. Football fields and playgrounds are great.

Launch area must be free of dry weeds and brown grass.

Launch only during calm weather with little or no wind and good visibility.

Don't leave parachute packed more than a minute or so before launch during cold weather [colder than 40° Fahrenheit (4° Celsius)].

Parachute may be dusted with talcum powder to avoid sticking.

# MISFIRES

Failure of the model rocket engine to ignite is nearly always caused by incorrect igniter installation. An Estes igniter will function properly even if the coated tip is chipped. However, if the coated tip is not in direct contact with the engine propellant, it will only heat and not ignite the engine.

When an ignition failure occurs, remove the safety key from the launch control system and wait one minute before approaching the rocket. Remove the expended igniter from the engine and install a new one. Be certain the coated tip is in direct contact with the engine propellant, then tape the igniter leads firmly to base of engine as illustrated above. Repeat the countdown and launch procedure.

# FOR YOUR SAFETY AND ENJOYMENT

Always follow the NAR\* MODEL ROCKETRY SAFETY CODE while participating in any model rocketry activities.

\*National Association of Rocketry

# COUNTDOWN AND LAUNCH

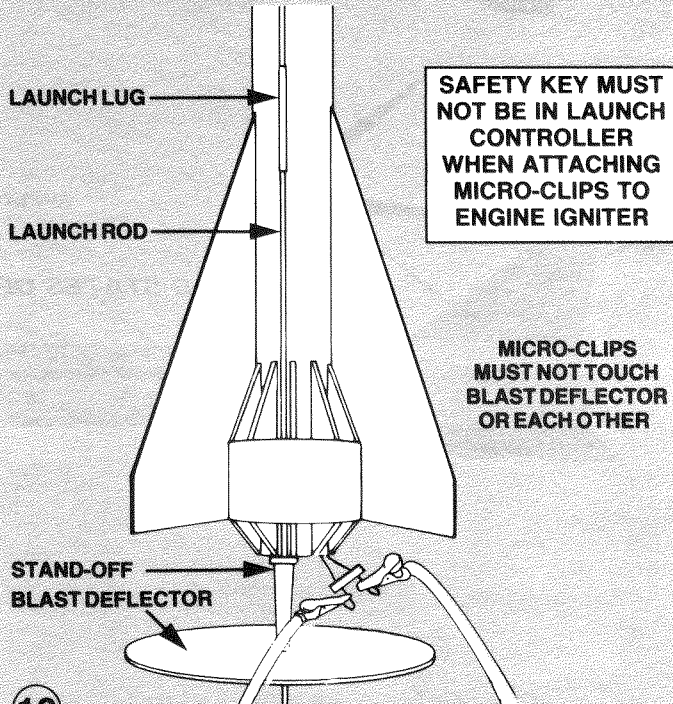

- 10** BE CERTAIN SAFETY KEY IS NOT IN LAUNCH CONTROLLER.
- 9** Remove safety cap and slide launch lug over launch rod to place rocket on launch pad. Make sure the rocket slides freely on the launch rod.
- 8** Attach micro-clips to the igniter wires. Arrange the clips so they do not touch each other or the metal blast deflector. Attach clips as close to protective tape on igniter as possible.
- 7** Move back from your rocket as far as launch wire will permit (at least 15 feet).
- 6** INSERT SAFETY KEY to arm the launch controller.  
Give audible countdown 5...4...3...2...1

**LAUNCH!!!** PUSH AND HOLD LAUNCH BUTTON UNTIL ENGINE IGNITES  
REMOVE SAFETY KEY FROM LAUNCH CONTROLLER.  
REPLACE SAFETY KEY AND SAFETY CAP ON LAUNCH ROD.

# FINISHING YOUR ROCKET

Apply decals in the positions shown. Cut decals apart, trimming excess clear as close to detail as possible. Dip one decal in lukewarm water for 20 seconds and hold until it uncurls. Slip decal off backing sheet and onto model. Move decal into exact position. Carefully blot away excess water. Smooth out any wrinkles or air bubbles with a soft cloth. When decals are completely dry, spray a coat of clear gloss over model to protect the model's finish and decals.

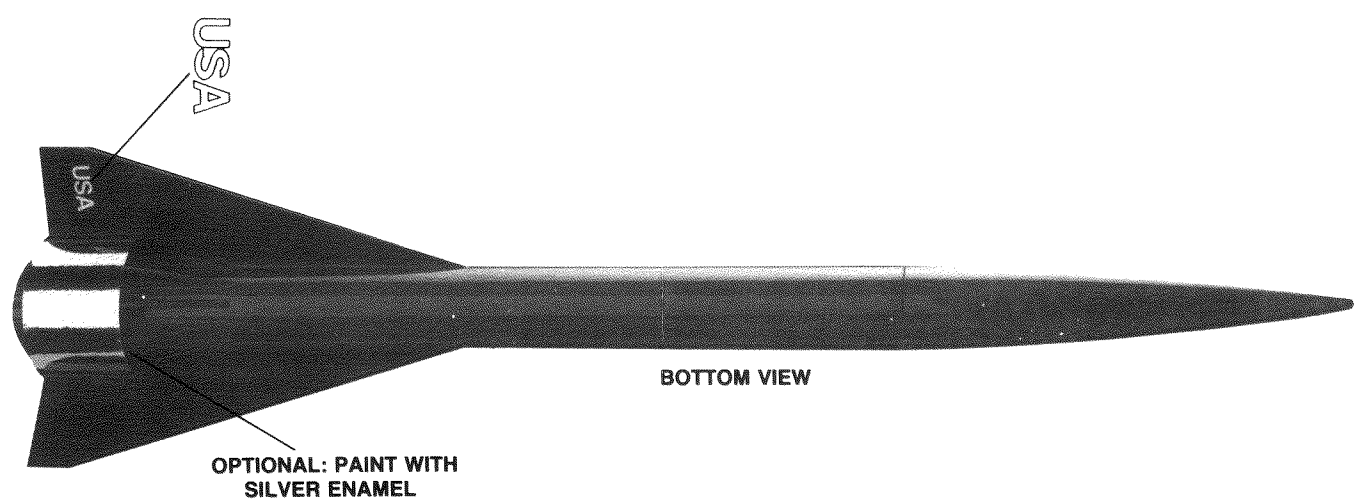
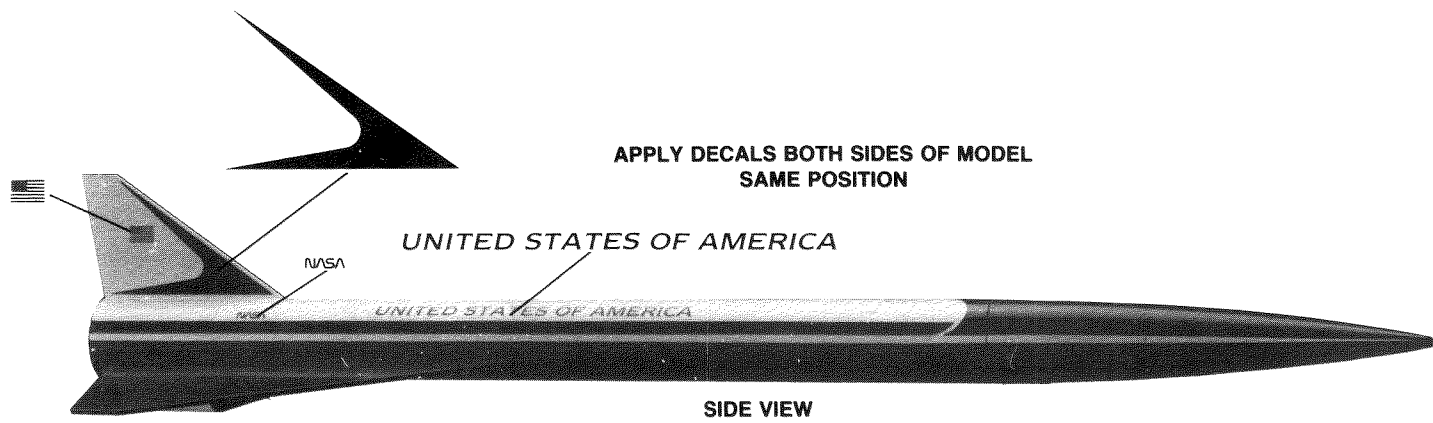
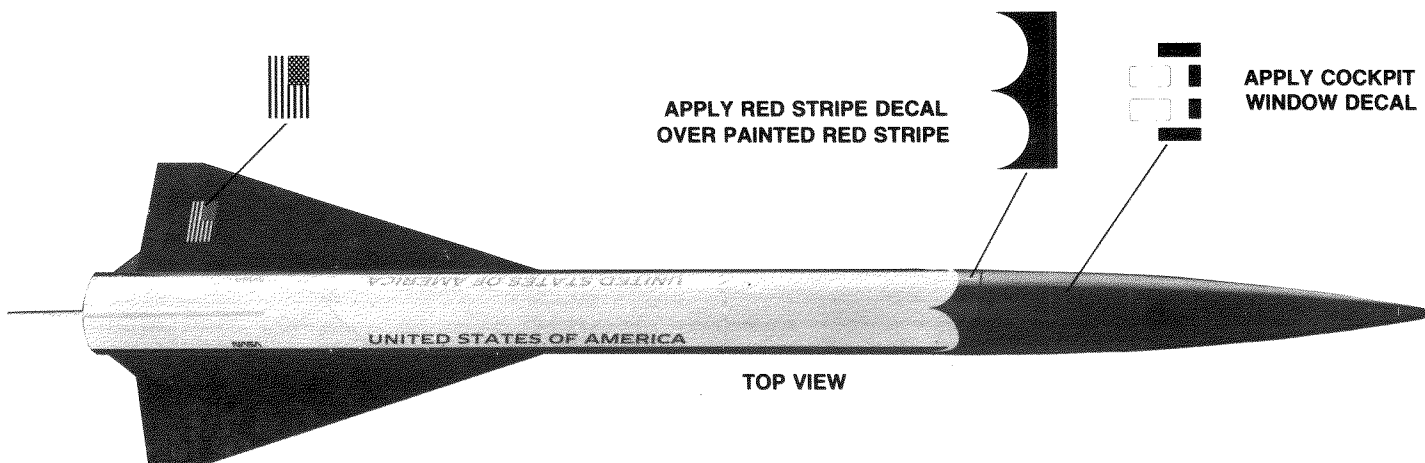



**Estes National Aerospace  
Plane (NASP)  
All Fins 3/32" Balsa**

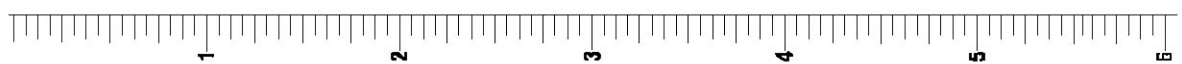

# UNITED STATES OF AMERICA UNITED STATES OF AMERICA



USA

ESTES INDUSTRIES PN37469

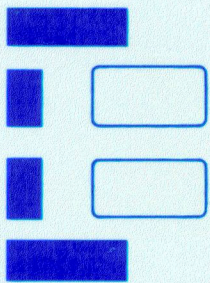

USA