





A DAMON COMPANY

ESTES INDUSTRIES
PENROSE, CO 81240 USA

MIGHTY MOE

#1951

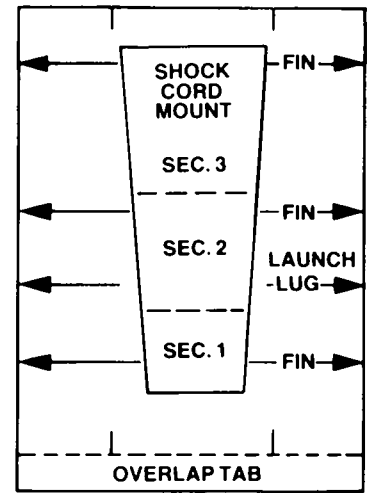

TUBE MARKING GUIDE

ASSEMBLY TIP

Read all instructions before beginning work on your model. Make sure you have all parts and supplies. Test-fit all parts together before applying any glue. If any parts don't fit properly, sand as required for precision assembly.

PARTS AND SUPPLIES

Locate the parts shown below and lay them out on the table in front of you. In addition to the parts included in the kit you will also need:

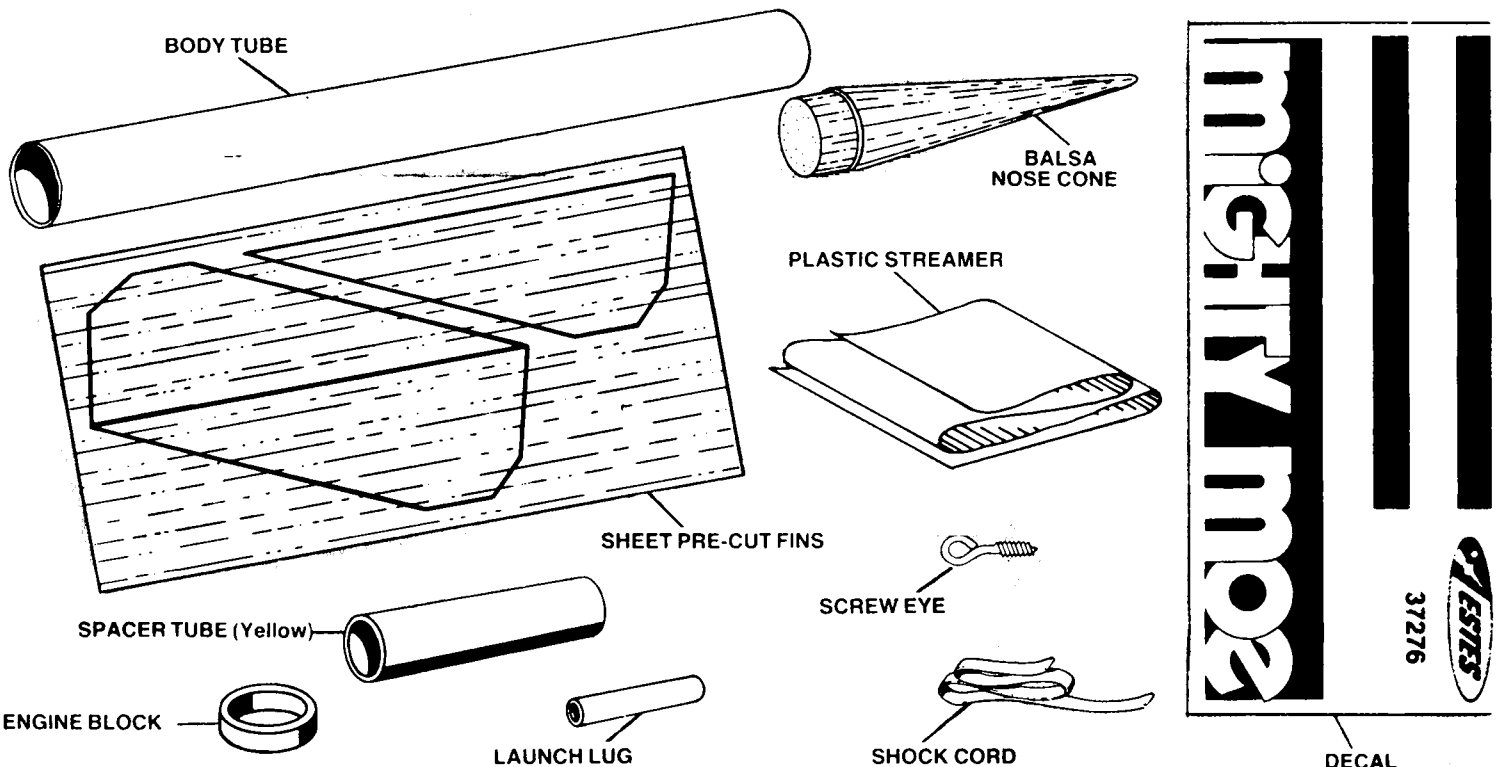
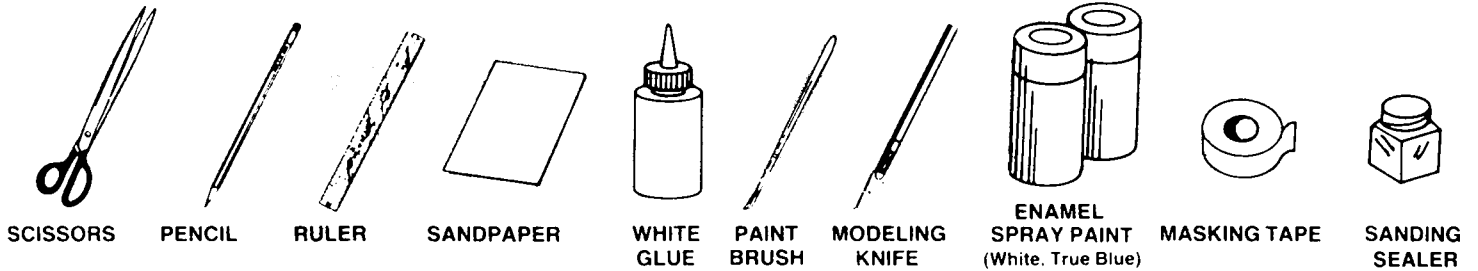

ROCKET ASSEMBLY

1

- Fine sand balsa die-cut sheet. Carefully remove fins by freeing edges with sharp knife.
- Stack fins together. Sand all edges smooth.

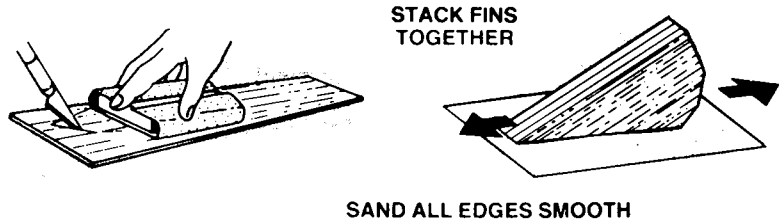

2

- Mark spacer tube 1/4" from one end.
- Using a piece of scrap balsa, smear glue inside body tube 2" from one end.
- Push engine block up into body tube with spacer tube until 1/4" mark is even with end of body tube and remove spacer tube immediately.

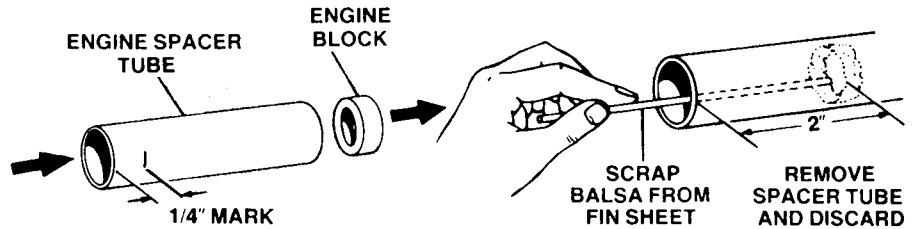

3

- Cut out tube marking guide from front of instructions.
- Wrap guide around the tube and mark tube at arrows. Mark launch lug line.
- Remove guide and save.
- Draw straight lines connecting each pair of marks.

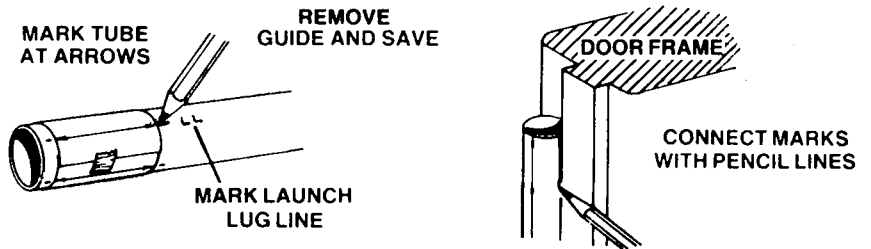

4

- Lay fins on pattern to find front (leading) and gluing (root) edges.
- Position and glue fins on alignment lines one at a time. Let each dry several minutes before applying the next one.
- Adjust fins to project straight out from tube.
- Do not set rocket on fins while glue is wet.

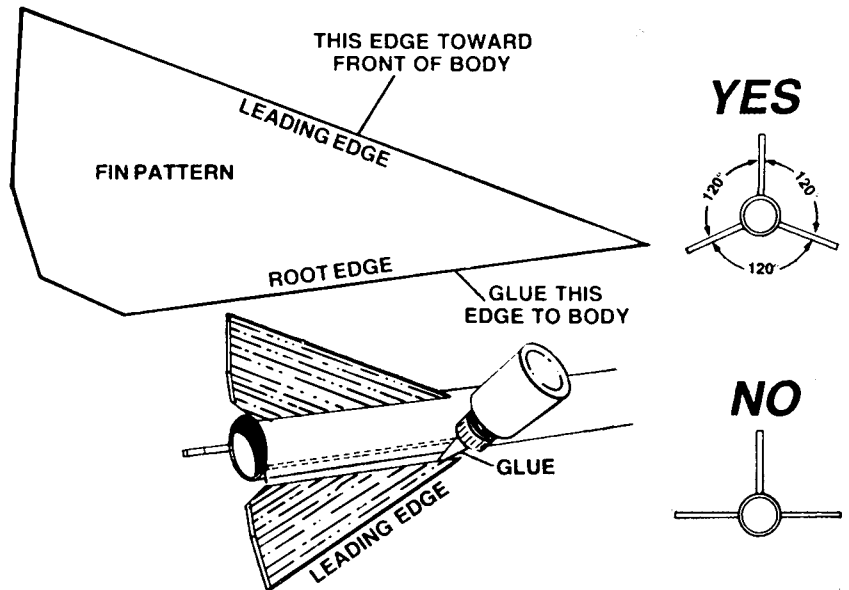

FINS MUST BE ATTACHED CORRECTLY FOR STABLE FLIGHT!

5

Glue launch lug on launch lug line even with end of body tube.

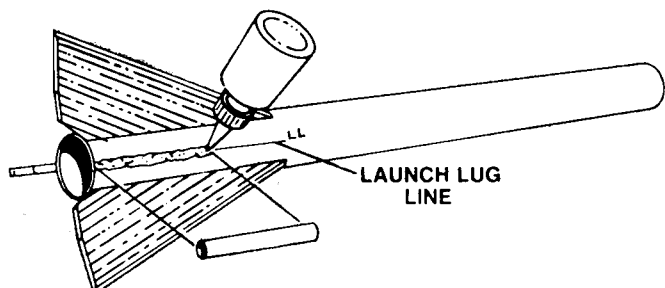

6

- Cut shock cord mount from tube marking guide.
- Crease on dotted lines by folding. Spread glue on section 1 and lay end of shock cord into glue. Fold over and apply glue to back of first section and exposed part of section 2. Lay shock cord as shown with fingers and fold mount over again.
- Clamp unit together with fingers until glue sets.

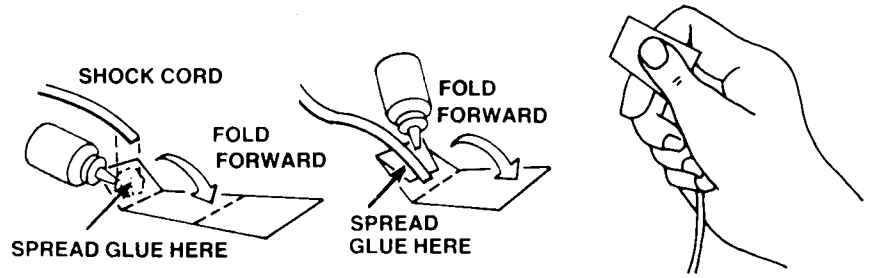

7

- Apply glue to inside front of body tube to cover an area no less than 1" to 2" from end. The glued area should be same size as shock cord mount.
- Press mount firmly into glue as shown.
- Hold until glue sets.

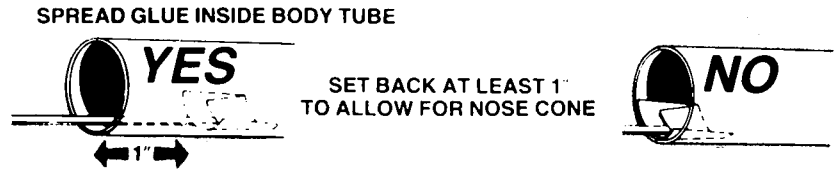

8

- Apply a glue reinforcement to both sides of each fin/body tube joint and each side of launch lug.
- Support rocket as shown until glue dries.

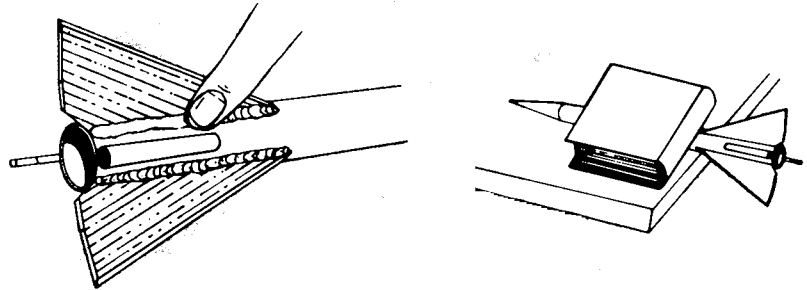

9

- Turn screw eye into center of nose cone shoulder and remove.
- Squirt glue into hole and replace screw eye.

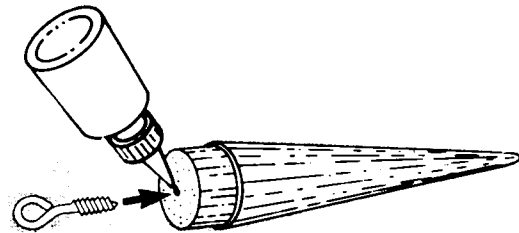

10

- Fold streamer in half and crease.
- Tie center of streamer to center of shock cord.
- Tie free end of shock cord to screw eye in nose cone.

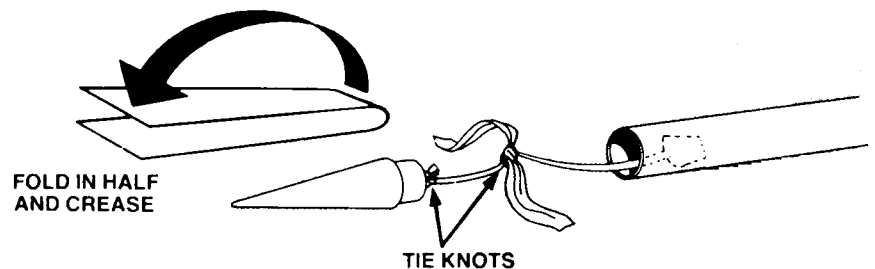

FINISHING YOUR ROCKET

Apply sanding sealer to wood parts with small brush. When sealer is dry, lightly sand all sealed surfaces. Repeat sealing and sanding until balsa grain is filled and smooth. When sanding sealer and glue are completely dry, paint model with spray enamel. Follow instructions on spray can for best results. Let paint dry overnight before masking to paint second color. To apply decals, cut each out, dip in lukewarm

water for 20 seconds and hold until it uncurls. Refer to photograph on front page and/or on front of panel for decal placement. Slip decal off backing sheet and onto model. Blot away excess water. For best results, let decals dry overnight and apply a coat of clear spray paint to protect decals.

ROCKET PREFLIGHT

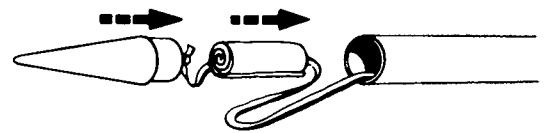
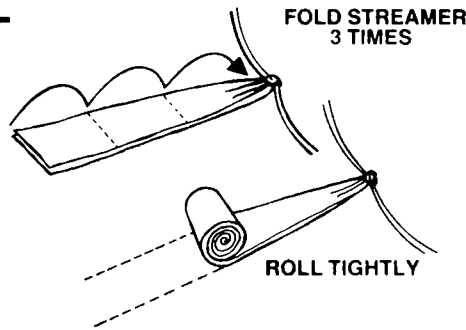
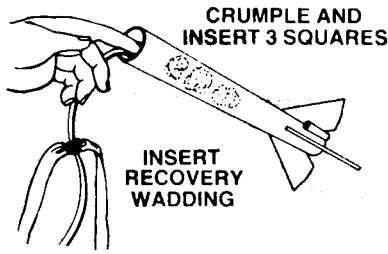

INSERT STREAMER, SHOCK CORD AND NOSE CONE INTO ROCKET BODY

NOTE: If streamer fits too tightly into body, remove and re-roll. A too-tight fit could cause an ejection malfunction during flight.

PREPARE ENGINE

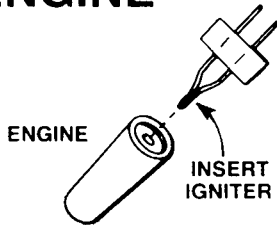

IGNITER TIP MUST TOUCH PROPELLANT DEEP INSIDE NOZZLE OPENING

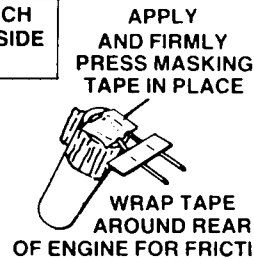
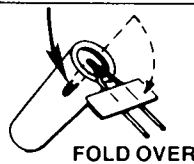

PUSH ENGINE INTO ROCKET UNTIL IT IS AGAINST ENGINE BLOCK

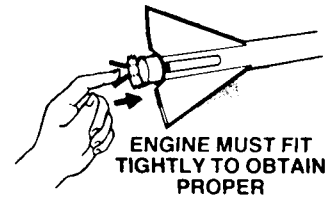

LAUNCH SUPPLIES

To launch your rocket you will need the following items:

- An Estes model rocket launching system
- Estes Parachute Recovery Wadding (No. 2274)
- Recommended Engines: A8-5, B4-6, B6-6, B8-5, C6-5, or C6-7

Use an A8-5 engine for your first flight, to become familiar with your rocket's flight pattern.

FLYING YOUR ROCKET

Choose a large field away from power lines, tall trees, and low flying aircraft. Try to find a field at least 250 feet square. The larger the launch area, the better your chance of recovering your rocket. Football fields and playgrounds are great.

Launch area must be free of dry weeds and brown grass.

Launch only during calm weather with little or no wind and good visibility.

Don't leave streamer packed more than a minute or so before launch during cold weather. (Colder than 40° Fahrenheit 4° Celsius).

MISFIRES

Failure of the rocket engine to function properly is nearly always caused by a failure to install the igniter correctly. This failure permits the igniter to heat and burn into two pieces without igniting the engine.

FOR YOUR SAFETY AND ENJOYMENT

Always follow the NAR-HIA* MODEL ROCKETRY SAFETY CODE while participating in any model rocketry activities.

COUNTDOWN AND LAUNCH

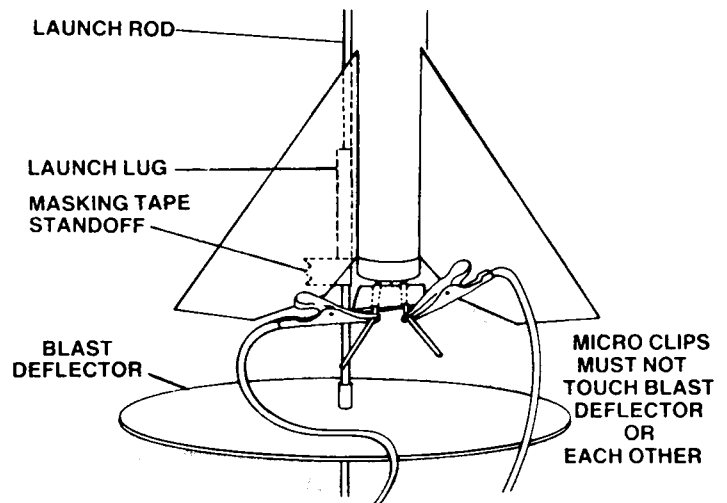

- ⑤ REMOVE SAFETY KEY to disarm the launch controller.
- ④ Remove safety cap and slide launch lug over launch rod to place rocket on launch pad. Make sure the rocket slides freely on the launch rod.
- ③ Attach micro-clips to the igniter wires. Arrange the clips so they do not touch each other or the metal blast deflector. Attach clips as close to protective tape on igniter as possible.
- ② Move back from your rocket as far as launch wire will permit (at least 15 feet).
- ① INSERT SAFETY KEY to arm the launch controller.

LAUNCH!! PUSH AND HOLD LAUNCH BUTTON UNTIL ENGINE IGNITES
Remove safety key—Replace cap on rod.

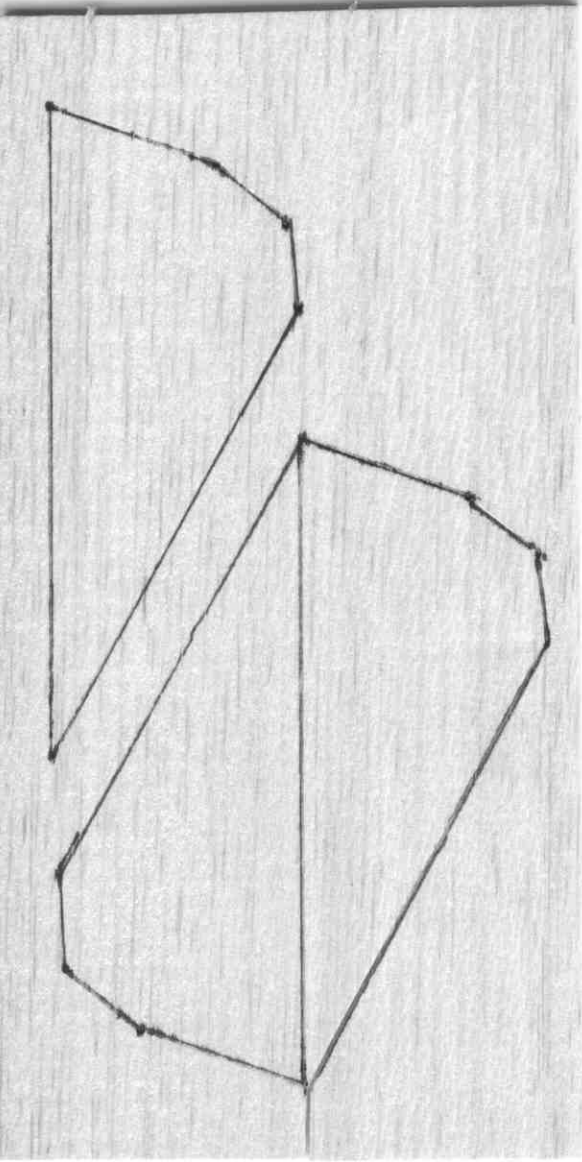



37276

migHty mos

Mighty Moe Estes #1951 Parts Measurements List

Quantity	Part Description	Length
1	Main Body Tube	9 3/4"
1	Engine Mount Tube	2 3/4"
1	1/8" Launch Lug	1 1/4"
1	Rubber Shock Cord	11 1/2"
1	1 1/4" Plastic Streamer	18"
1	3/8" Eye Screw	1"

*Note: Balsa Fin Thickness is 3/32"

MIGHTY MOE

FLYING MODEL ROCKET

SKILL LEVEL 1

Recommended for the Beginning Modeler

- High Performance
- Delta-Shaped Fins
- Streamer Recovery

Length: 13 in. (33.02 cm)

Dia: .736 in. (18.7 mm)

Weight: .44 oz. (12.48 g)

Recommended Engines:

A5-5 (First Flight), B4-6,

B6-6, B8-5, C6-5, C6-7

**ENGINE
FLIGHTS
TO
1,000
FEET**



A HORNBY COMPANY

ESTES INDUSTRIES
PENROSE, CO 81060 USA

#1951

This is a model kit requiring assembly. Glue and finishing supplies, launch system and engines for flight are not included.

