



MARAUDER

SKILL LEVEL 1 - RECOMMENDED FOR BEGINNING ROCKETEERS

BEFORE YOU START

Read each step and study the accompanying drawings before doing any of the work called for in that step. Make sure you have all parts and materials. Check off each step as you complete it. Always test-fit parts together before applying glue. It will sometimes be necessary to sand edges of rings, tubes, etc. to obtain proper fit. If you are in doubt about the relative size or location of some parts, refer back to this exploded view drawing for clarification. Adequate glue joints are very important for a flying model rocket. Follow the instructions carefully in this regard.

INCHES
1
2
3
4
5
6
7
8
9
10

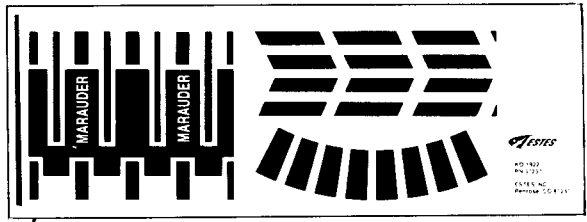
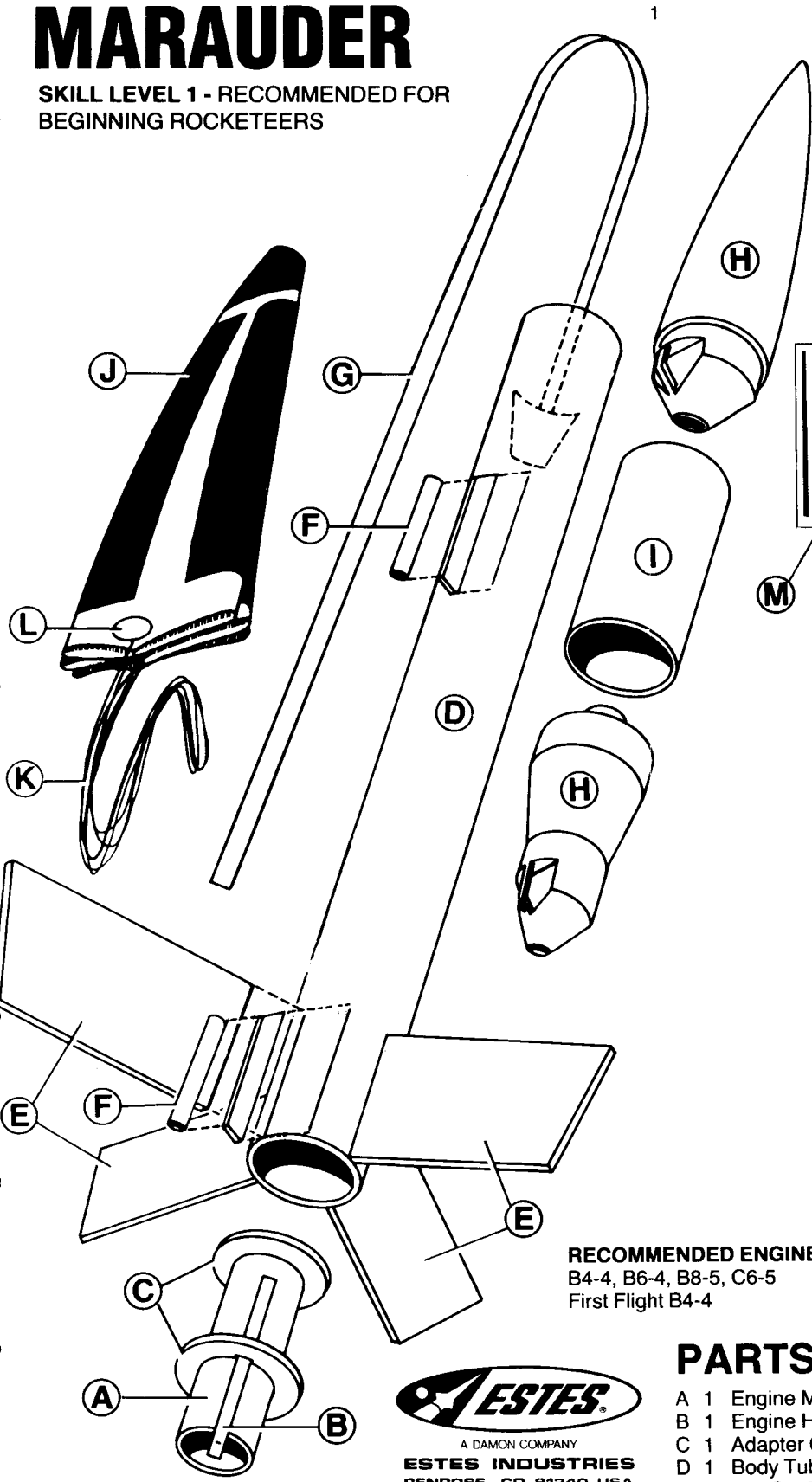

RECOMMENDED ENGINES:
B4-4, B6-4, B8-5, C6-5
First Flight B4-4



TOOLS AND MATERIALS

In addition to the parts included in this kit you will need: Scissors, pencil, ruler, fine or extra-fine grit sandpaper, sanding sealer, a medium-size modeling paint brush, masking tape, modeling knife with sharp blade, gloss white, red and black spray paints, and household white glue, resin glue (Elmer's, Titebond, or similar), and tube-type plastic cement. Other types of glue are not recommended.

PARTS LIST

KIT #1922

A	1	Engine Mount Tube (type BT-20J)	30326
B	1	Engine Hook (type EH-2)	35025
C	1	Adapter Centering Rings (type TA-1327)	30090
D	1	Body Tube (type BT-55KA)	30387
E	1	Die-Cut Balsa Sheet (type BF-1907)	32607
F	1	Launch Lug (type LL-2A)	38175
G	1	Shock Cord (type SC-1)	85730
H	1	Nose Cone (type PNC-60NA)	72057
I	1	Body Tube (type BT-60J)	30412
J	1	Parachute (type PK-12A)	85564
K	1	Shroud Line (type SLT-72)	38237
L	1	Tape Disc Strip (type TD-3F)	38406
M	1	Decal Sheet (type KD-1922)	37237

ASSEMBLY INSTRUCTIONS

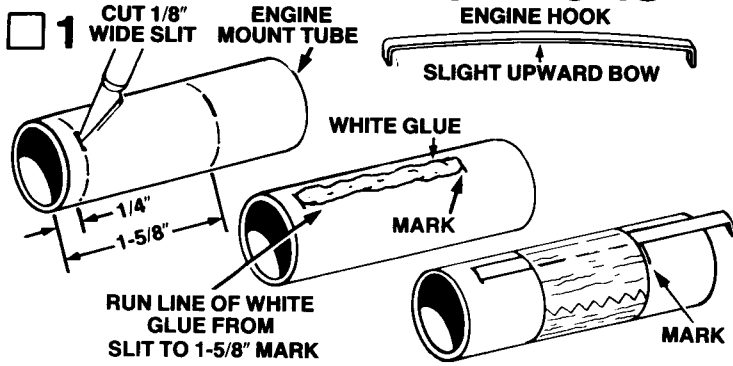

Mark the engine mount tube (part A) $1/4$ " and $1-5/8$ " from one end. Use a sharp modeling knife to cut a $1/8$ " wide slit at the $1/4$ " mark. Insert one end of the engine hook (part B) into the slit and lay the hook into the glue straight along the tube. Wrap two layers of masking tape around the hook and tube with one edge of the tape next to the mark as shown.

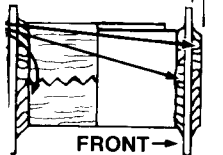

separate them from the rear and down. Apply a line of it touches the tube. e tube and position it its glue around both h out with finger. Let

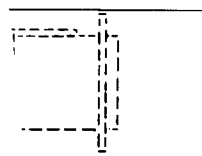
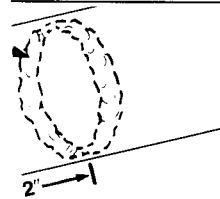

of the body tube from the rear of the e as shown until the

end of the engine mount tube is even with the body end. Do not pause when pushing the mount in or the glue may "grab" at the wrong place!

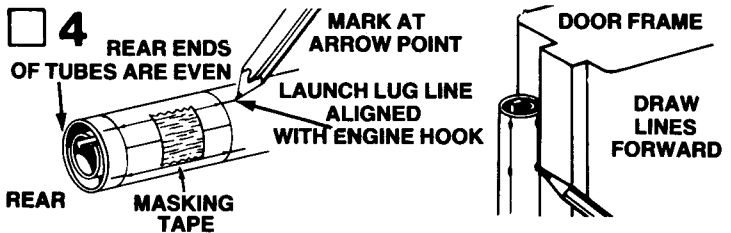

Cut out the body tube marking guide from page 1 of the instruction sheet. Wrap it around the rear of the body tube with the launch lug line in line with the engine hook. Mark the tube at each arrow point, front and rear. Draw a straight line connecting each matching front and rear mark. (Use a door sill when drawing lines.) Extend the launch lug line forward 10" (align launch lug line with engine hook).

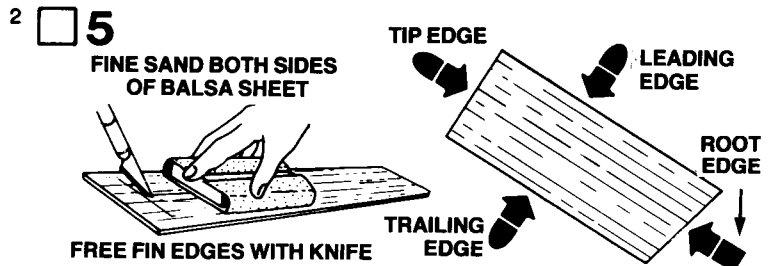

Fine-sand the balsa sheets (part E), then carefully remove the die-cut fins from the sheet. Free the edges with a sharp knife. Sand the leading, tip, and trailing edges of the fins round. Leave the root edge square. Do not discard the remaining balsa sheet just yet.

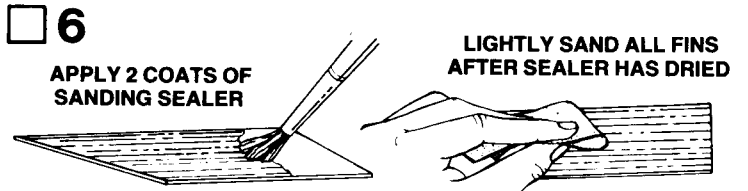

Apply a coat of sanding sealer to each fin. Apply sealer to all edges except the root edge. When sealer is dry, lightly sand all the sealed surfaces. Repeat sealing and sanding process until balsa grain no longer shows. Resand root edge, lightly, to remove any trace of sealer.

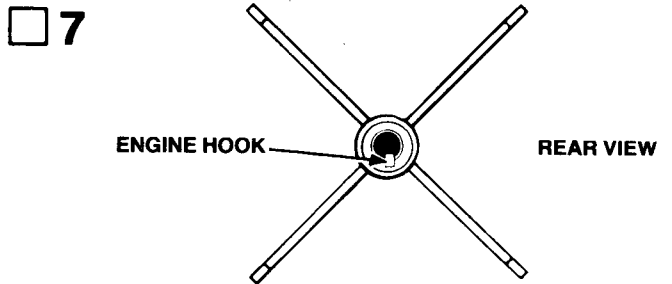

Rub a line of glue into the root edge of each fin and allow to dry. Apply glue to the fins and position fins on the alignment lines in their correct positions on the tube. Refer to the illustration to be sure of these positions. Adjust the fins so they project straight away from the body tube. Do not set the rocket on its fins while the glue is wet.

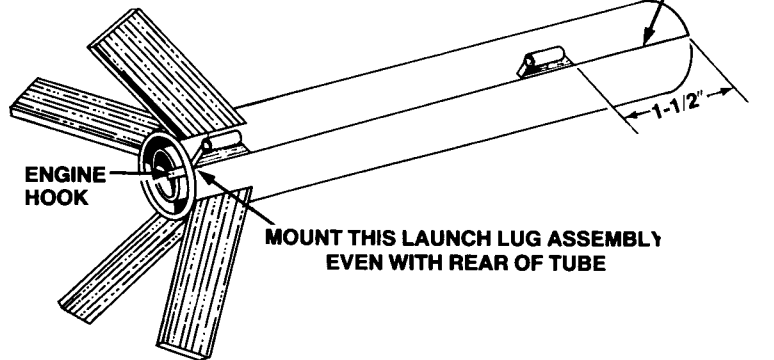
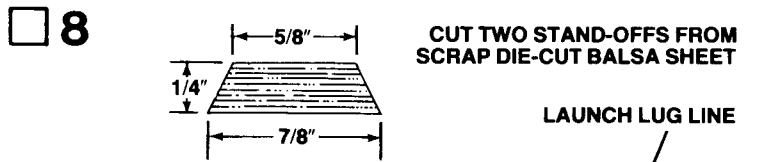

Cut two launch lug stand-offs from the remaining scrap of the die-cut fin sheet, to the dimensions shown. Use a sharp modeling knife to cut the launch lug (part F) into two $5/8$ " long sections. Glue the two launch lugs to the two balsa stand-offs, align them straight, and allow to dry. Now glue the two launch lug assemblies on the launch lug alignment line in the positions shown. Be sure these are mounted straight on the tube before the glue sets.

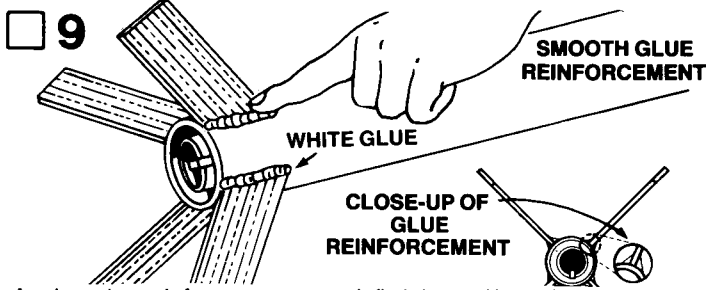

Apply a glue reinforcement to each fin joint and launch lug. Holding the model level, apply a line of glue to both sides of each joint. Smooth out the glue with your finger. Keep the model level until the glue dries.

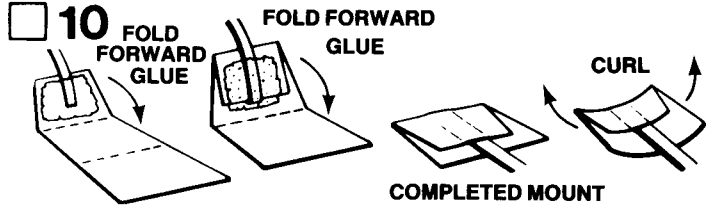

Cut out the shock cord mount from the middle of the tube marking guide. Crease it on the dotted lines by folding. Spread glue on the first section (1) and lay the end of the shock cord (part G) into the glue. Fold over and apply glue to the back of the first section and the exposed part of section 2. Lay the shock cord as shown and fold over again. Clamp the unit together with your fingers until the glue sets.

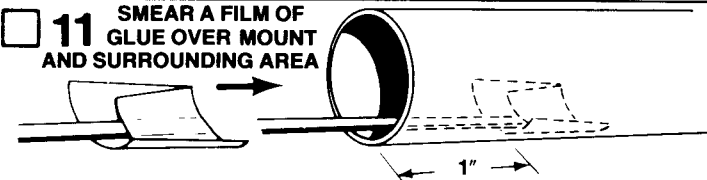

Use a stick or scrap dowel to apply a generous amount of glue inside the body tube 1" from the front of the tube. Slide the shock cord mount into the tube and press it into the glue. To insure a good bond use a stick or your finger to smear a film of glue over the mount and surrounding area in the body tube.

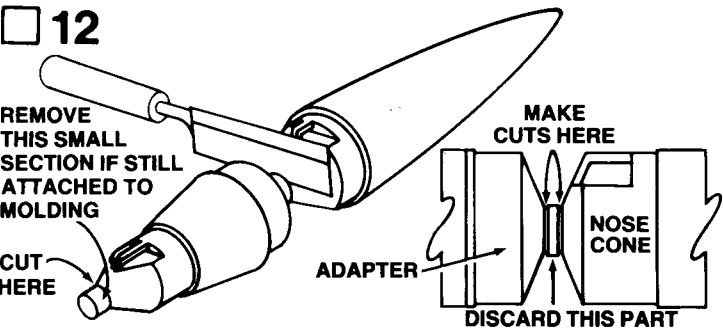

Separate the nose cone/adaptor (part H) using either a sharp modeling knife or modeler's saw. Use the grooves molded into the part as cutting guides. Discard the small section of plastic removed between the two parts as it is not used. You will also need to cut away and discard the small tubular section at the base of the adaptor if it has not already been removed.

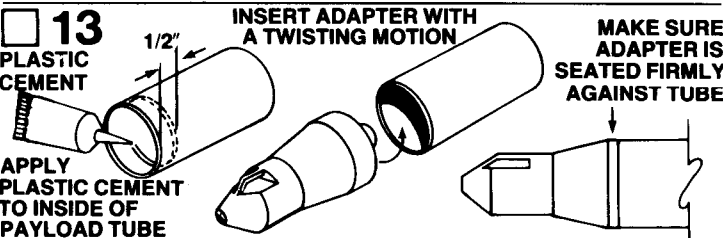

Apply a liberal amount of tube-type plastic cement around the inside of one end of the payload tube (part I). The cement should be about 1/2" from the end of the tube. Insert the adaptor with a twisting motion and its shoulder is seated firmly against the payload tube end. Set aside to dry thoroughly. Cement the nose cone into the payload tube, in exactly the same manner as the adaptor. Set aside to dry thoroughly.

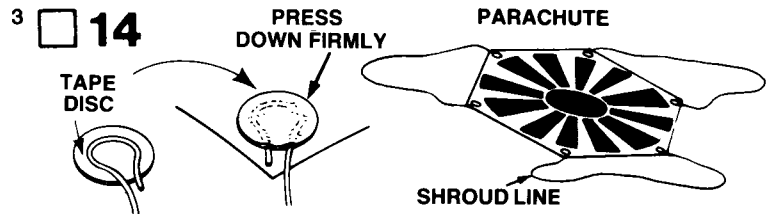

Cut out the 12" parachute (part J) on its edge lines. Cut three equal lengths of shroud line from the 72" long shroud line (part K). Attach line ends to the top of the parachute with one set of tape discs (part L) as shown. Form a small loop in the end of the shroud line. Holding the loop, gently center it inside the tape disc on the sticky-side. Then carefully press the disc onto its proper place on top of the parachute. Firmly press the tape disc into place until both the disc and parachute material are molded around the shroud line loop. Repeat for the other shroud line ends and tape discs. Set the completed parachute aside until needed in Step 19.

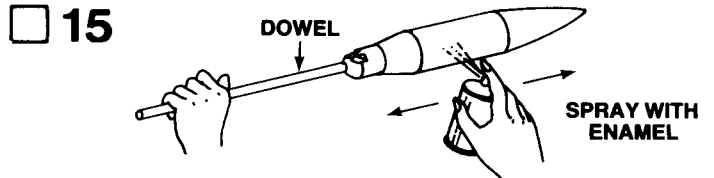

Spray paint the payload section with several light coats of gloss black paint. The payload section can be supported by a dowel or stick inserted in the center opening in the adapter while being painted and drying.

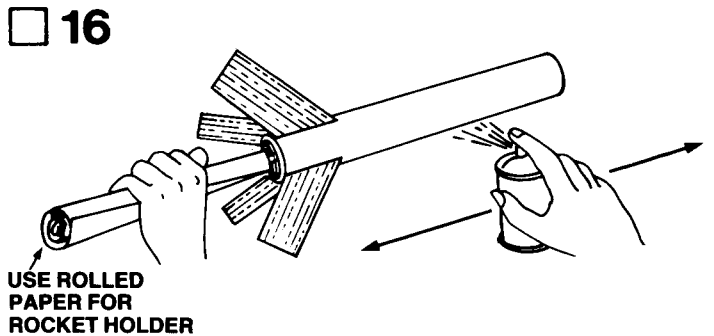

After the sanding sealer is completely dry, paint the entire rocket body and fins with gloss white spray enamel. Follow instructions on the spray can for best results. We recommend spray enamel. Do not paint the model with lacquer paint. Shake can before spraying. Hold the can straight up and spray in long smooth "strokes". Spray the model with several light, dry mist coats of paint to avoid "runs". Shake can periodically. To obtain a gloss, final coat should be applied slightly heavier. Let this coat dry overnight.

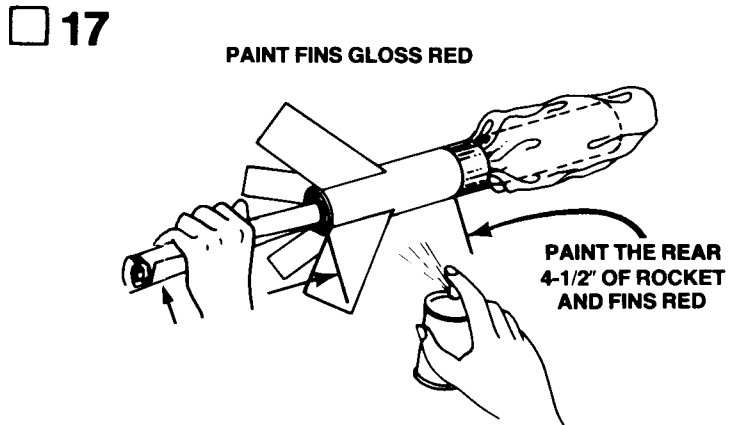

Apply masking tape and paper to cover and protect the areas which will remain white (See the panel or Decor Layout illustration.) Paint the fins and the rear of the body tube red. Carefully remove the masking tape and paper as soon as the paint is dry.

□ 18

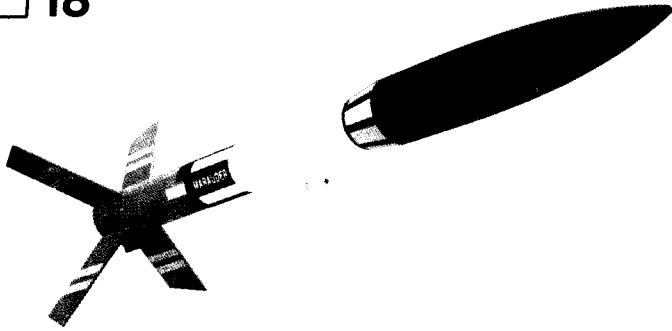

When all paint is dry, apply the decals (part M) in the positions shown. (A) Cut only one decal at a time from sheet. (B) Submerge decal in lukewarm water until decal slides on backing paper (usually 15 to 30 seconds). (C) Gently slide decal from backing paper onto model. (D) Move decal into exact position and carefully blot away excess water with a soft cloth. (E) If the decal "sticks" before you have it in position, apply water over the decal with a brush. This will permit the decal to be moved. (F) Smooth out all wrinkles and air bubbles before the decal dries. We recommend that the completed model be sprayed with Testor's "Gloss Cote". This is a clear spray paint that protects the model's finish.

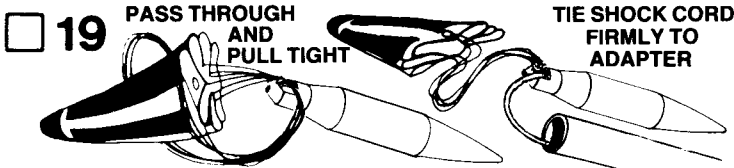

Pass the shroud line loops through the loop on the adapter. Pass the parachute through the loop ends and pull the lines tight against the adapter. Tie the free end of the shock cord firmly to the adapter. Tie the free end of the shock cord firmly to the adapter loop. A square knot or strong double knot should be used. Pack parachute and shock cord into rocket body and slip adapter into place.

LAUNCHING COMPONENTS

Be sure to follow the HIAA-NAR* Model Rocket Safety Code when carrying out your model rocket activities.

*HIAA—Hobby Industry of America

*NAR—National Association of Rocketry

To launch your model you will need the following items:

An Estes model rocket launch system

Parachute recovery wadding (Estes Cat. No. 2274)

Recommended Engines: B4-4, B6-4, B8-5, B8-5, C6-5.

Use an B4-4 Engine for your first flight.

COUNTDOWN CHECKLIST

T-13 Pack 4 or 5 squares of loosely crumpled recovery wadding into the body tube.

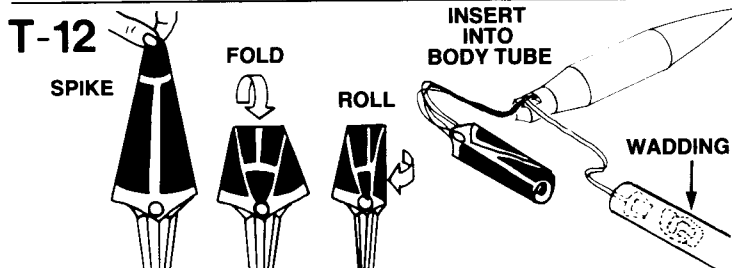

Hold the parachute at its center and pass the other hand down it to form a "spike" shape. Fold this spike in half. Roll parachute into tube shape to fit easily into body. Pack 'chute into the tube on top of the wadding. Pack the shroud lines and shock cord in on top of the parachute and slip the adapter section into place.

4

NOTE: Adapter section should separate easily from rocket body tube, but should not be extremely loose. If fit is too tight, sand inside of body tube and shoulder of adapter with fine sandpaper. If fit is too loose, add a wrapping of transparent tape to the shoulder of the adapter.

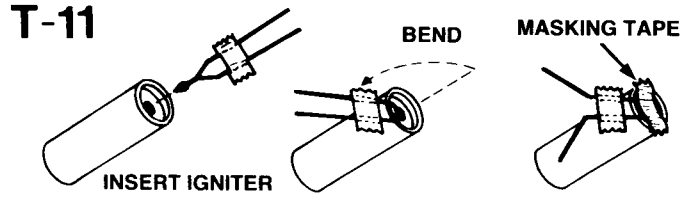

Select an engine and install an igniter as directed in the engine instructions. Use a B4-4 engine for your first flight.

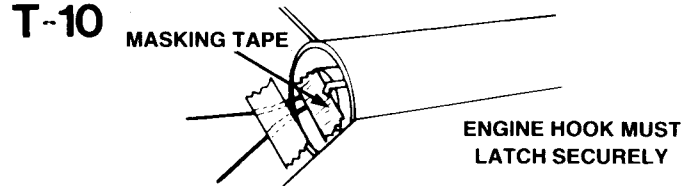

Insert engine into rocket engine mount. Engine hook must latch securely over end of the engine.

T-9 Disarm the launch panel—REMOVE SAFETY KEY!

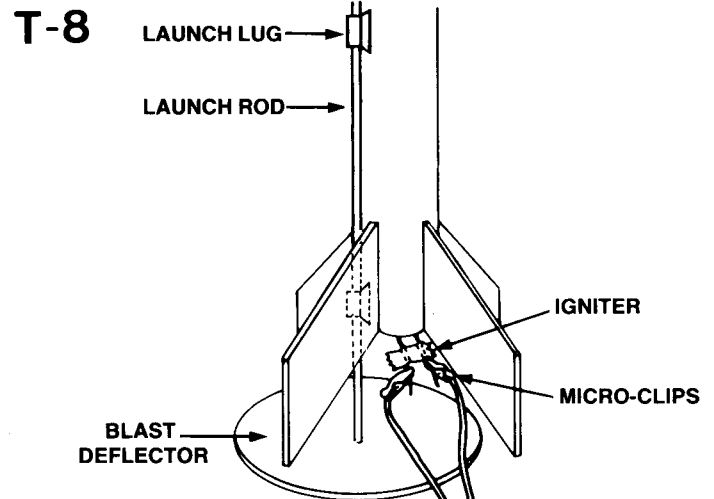

Slide launch rod through rocket launch lug and place rocket on launch pad. Make sure the rocket slides freely on the launch rod. Clean the micro-clips and attach them to the igniter wires. Arrange the clips so they do not touch each other or the metal blast deflector. Attach clips as close to protective tape on igniter as possible.

T-7 Clear the launch area. Alert recovery crew and trackers. Check for low flying aircraft and unauthorized persons in the recovery area.

T-6 Arm the launch panel—INSERT SAFETY KEY!

5-4-3-2-1-LAUNCH!!

Repeat Countdown Checklist for each flight.

MISFIRE PROCEDURE

Disarm the launch panel. Wait one minute before approaching the rocket on the launch pad. Remove the rocket, clean the igniter residue from the nozzle of the engine, and carefully install a new igniter. Repeat the Countdown Checklist.

Failure of the rocket engine to function properly is nearly always caused by a failure to install the igniter correctly. This failure permits the igniter to heat and burn into two pieces without igniting the engine.

Estes #1922 Marauder

Parts List and Full-Size Fin Pattern

Parts List

Nose Cone	1	PNC-60NA
Payload Body Tube	1	BT-60J
Transition	1	(P)TA-5560 [Part of PNC-60NA]
Main Body Tube	1	BT-55KA
Centering Rings	2	CR-2055
Engine Block	1	CR-520
Engine Hook	1	BMSEH-275
Launch Lug	1	LL-18-125 [Cut into two pieces]
Fin Stock	1	BFS-30 [3/32" x 3" x 7"]
Parachute Kit	1	PK-18

General Instructions

Typical 4FNC construction. In one of the CR-2055 rings, sand a flat notch in the inside diameter to accept the engine hook. Cut a slot in the motor tube 1/4" down from the top to accept one end of the engine hook. Insert hook, then slip the CR-520 ring into the top of the motor tube and press down until it contacts the hook. Glue in place. Slip the non-notched CR-2055 over the motor tube from the top and press down until it contacts the hook. Glue in place. Slide the notched CR-2055 over the bottom of the motor tube, trapping the hook between it and the tube, and continue pushing upward until ring is 3/4" from the bottom. Make sure the hook is aligned with the motor tube center line. Glue ring in place. Mount engine mount in one end of the main body tube, with the bottom of the engine tube flush with the bottom of the main tube. The engine hook should stand proud from the bottom 1/4".

Cut the launch lug into two pieces, and mount each half on the short edge of the standoffs.

Glue one lug/standoff on a line halfway between two fins, with the bottom of the standoff 1.5" up from the bottom of the main tube.

Glue the second lug/standoff on the same line, with the bottom of the standoff 9" up from the bottom of the main tube.

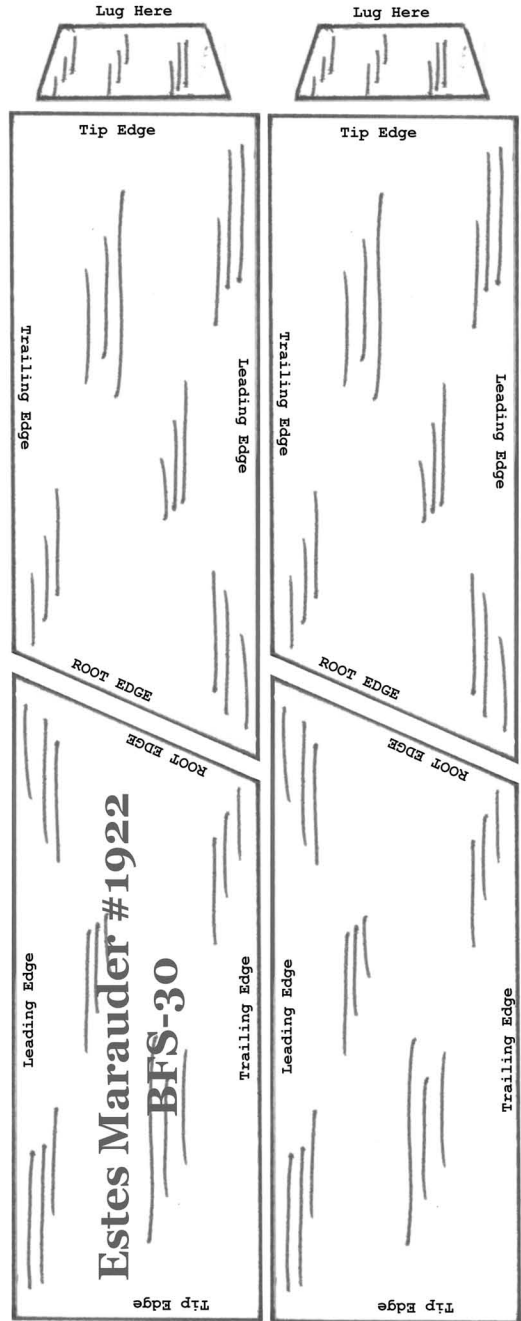

MARAUDER

MARAUDER



KD-1922
PN 37237

ESTES IND
Penrose, CO 81240



KD-1922
PN 37237

ESTES IND
Penrose, CO 81240

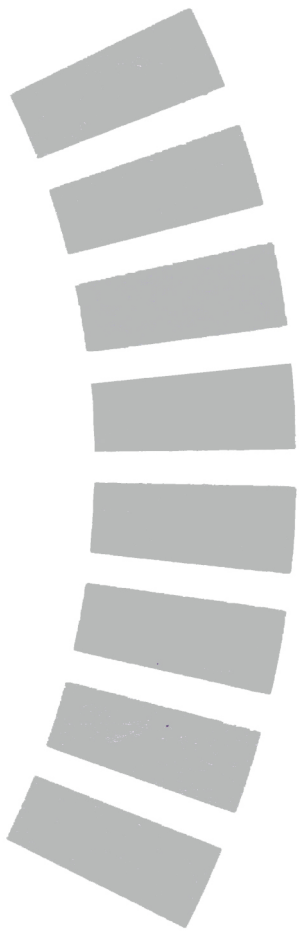



MARAUDER

MARAUDER

MARAUDER

FLYING MODEL ROCKET

SKILL LEVEL 1

1-Beginner 2-Intermediate 3-Craftsman
4-Advanced 5-Expert

- Easy to Build
- 12" Parachute Recovery
- Plastic Nose Cone
- Die-Cut Balsa Fins
- Huge Two-Color Decal

Length: 20.3 in. (51.7 cm)

Dia: 1.325 in. (34 mm)

Payload Dia.: 1.637 in. (41.6 mm)

Weight: 2.3 oz. (65 g)

Engine Types: B4-4 (First Flight),
B6-4, C6-5

FLIGHTS
OVER
600
FEET!

This is a hobby kit requiring assembly. Recommended for ages 10 to adult. Engines, launch system, glue and finishing supplies are not included. Adult supervision suggested for those under 12 years of age when flying model rockets.



A DAMON COMPANY

#1922

ESTES INDUSTRIES
PENROSE, CO 81240 USA



47776 01922