



MAVERICK

FLYING MODEL ROCKET

SKILL LEVEL 1
Recommended for the Beginning Modeler.

- Super Sport Rocket
- Two-Color Decal
- Streamer Recovery

Length: 16.5 in. (41.9 cm)
Dia: .976 in. (24.8 mm)
Weight: 1.13 oz. (32 g)
Recommended Engines:
 A8-3 (First Flight), B4-4, B6-4,
 B8-5, C6-5

This is a model kit requiring assembly. Glue and finishing supplies, launch system and engines for flight are not included.

**FLIGHTS
OVER
1000 FEET**

#1904



A DAMON COMPANY
ESTES INDUSTRIES
PENROSE, CO 81240 USA



INCHES
1
2
3
4
5
6
7
8
9
10

MAVERICK

SKILL LEVEL 1 - Recommended for Beginning Rocketeers

RECOMMENDED ENGINES:
A8-3, B4-4, B6-4, B8-5, and C6-5
First Flight A8-3

BEFORE YOU START

Read each step and study the accompanying drawings before doing any of the work called for in that step. Make sure you have all parts and materials. Check off each step as you complete it. Always test-fit parts together before applying glue. It will sometimes be necessary to sand edges of rings, tubes, etc. to obtain proper fit. If you are in doubt about the relative size or location of some parts, refer back to this exploded view drawing for clarification. Adequate glue joints are very important for a flying model rocket. Follow the instructions carefully in this respect.

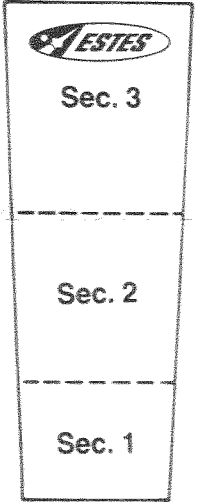
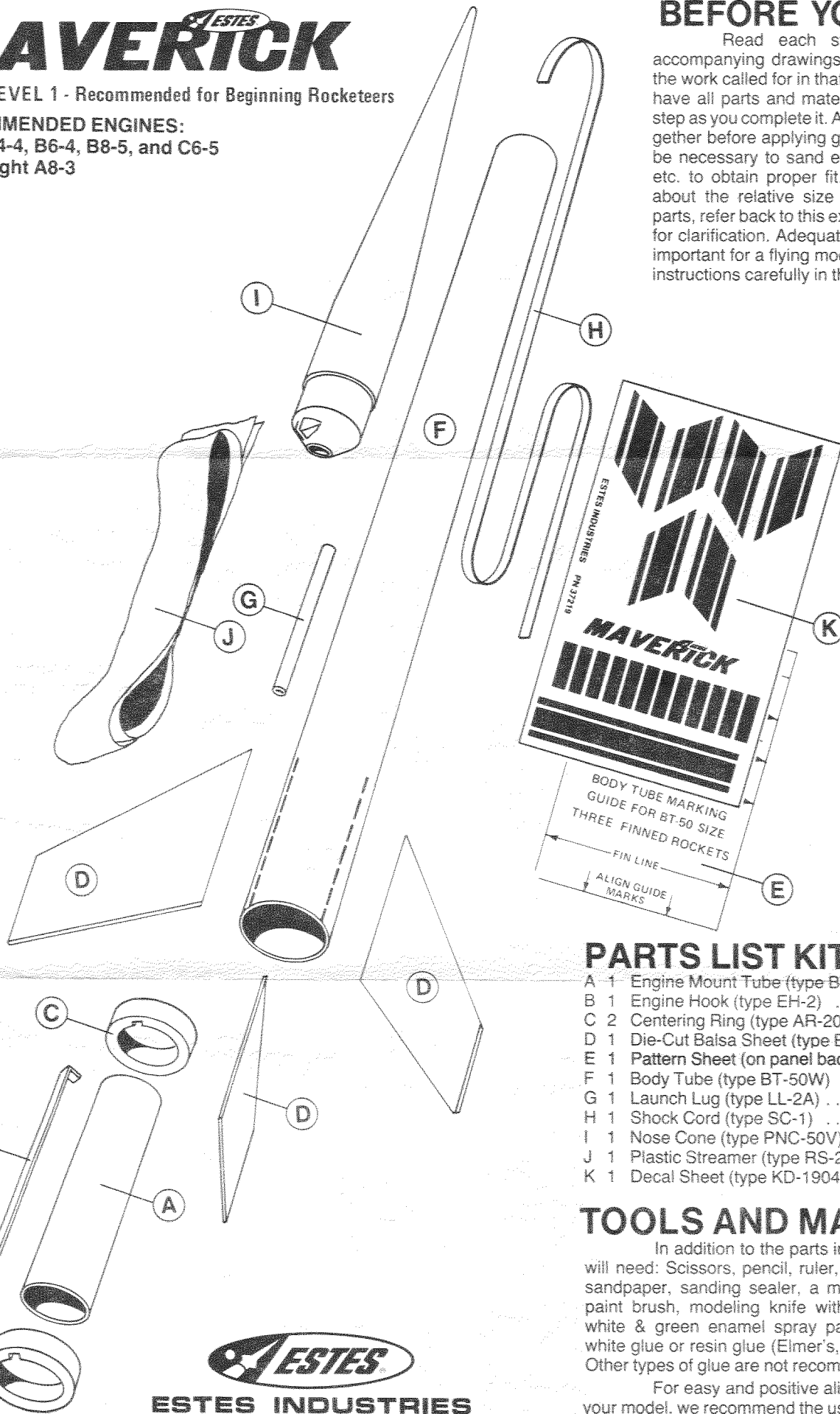

SHOCK CORD MOUNT
(to be cut out here)

PARTS LIST KIT NO. 1904

A	1	Engine Mount Tube (type BT-20J)	30326
B	1	Engine Hook (type EH-2)	35025
C	2	Centering Ring (type AR-2050)	30164
D	1	Die-Cut Balsa Sheet (type BF-1904)	32604
E	1	Pattern Sheet (on panel back)	83622
F	1	Body Tube (type BT-50W)	30372
G	1	Launch Lug (type LL-2A)	38175
H	1	Shock Cord (type SC-1)	85730
I	1	Nose Cone (type PNC-50V)	71025
J	1	Plastic Streamer (type RS-20)	38278
K	1	Decal Sheet (type KD-1904)	37219

TOOLS AND MATERIALS

In addition to the parts included in this kit you will need: Scissors, pencil, ruler, fine or extra-fine grit sandpaper, sanding sealer, a medium-size modeling paint brush, modeling knife with sharp blade, gloss white & green enamel spray paints, and household white glue or resin glue (Elmer's, Titebond, or similar). Other types of glue are not recommended.

For easy and positive alignment of the fins on your model, we recommend the use of Estes' Fin Alignment Guide, Part No. 2231.



ESTES INDUSTRIES
PENROSE, CO 81240 USA

ASSEMBLY INSTRUCTIONS

1

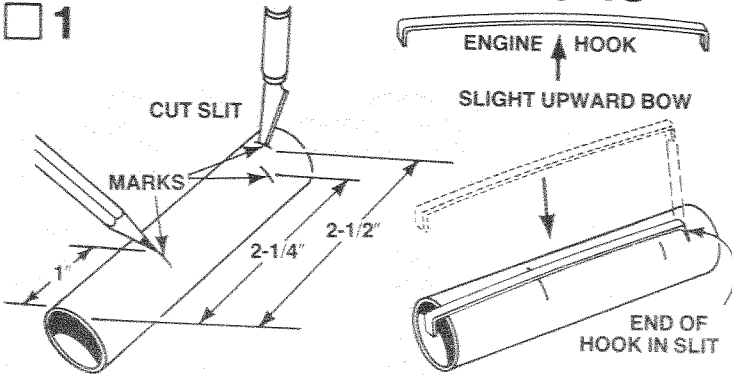

Mark the engine mount tube (part A) at 1", 2-1/4", and 2-1/2" from one end. Cut a 1/8" long slit at the 2-1/2" mark. Gently bend the engine hook (part B) so that it bows upward very slightly in the middle. (Study the drawing — Don't bend the wrong way.) Insert one end of the engine hook into the slit in the tube.

2

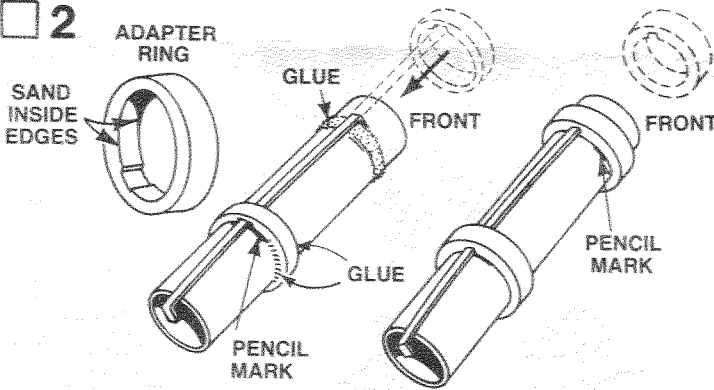

Sand the inside edges of the two centering rings (part C) to remove burrs. The rings should slide easily onto the engine mount tube. Cut a very shallow 1/8" wide slot inside the two centering rings so they will fit over the engine hook. Slip one ring onto the forward end of the engine mount tube and slide it down to the 1" mark. Make sure the engine hook runs straight down the tube, then apply glue to both sides of this ring. Apply glue around the tube at the 2-1/4" mark and slide the remaining centering ring into place down to the 2-1/4" mark.

3

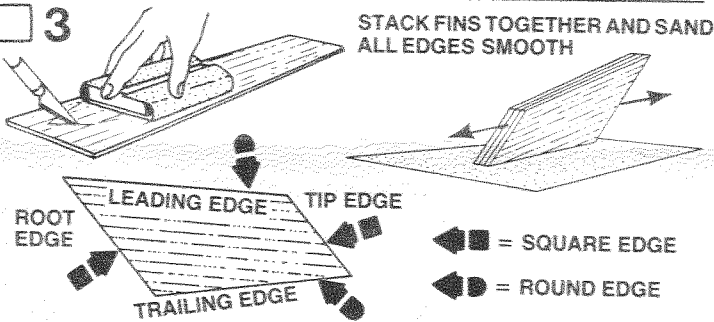

Fine-sand the balsa die-cut sheet (part D), then carefully remove the die-cut fins from the sheet. Free the edges with a sharp knife. Sand the leading and trailing edges of the fins round. Leave other edges square.

4

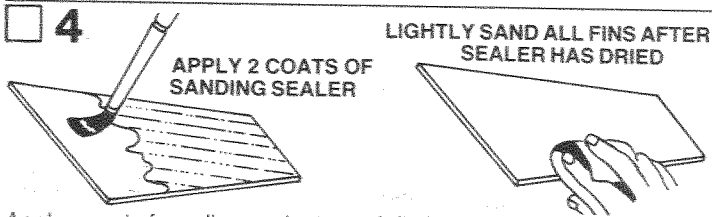

Apply a coat of sanding sealer to each fin. Apply sealer to all edges except the root edge. When sealer is dry, lightly sand all sealed surfaces. Repeat sealing and sanding process until balsa grain no longer shows. Resand root edge, lightly, to remove any trace of sealer.

5

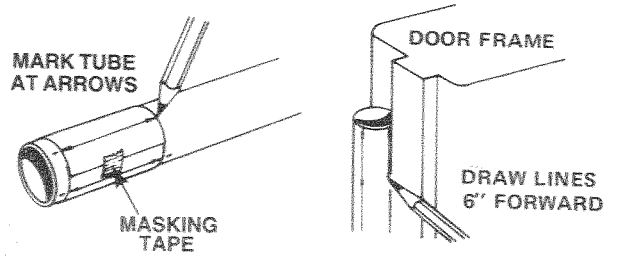

Cut out the tube-marking guide (part E) from the back of the display panel, and wrap it around the body tube (part F). Mark the body tube at each of the arrow points. Draw straight lines connecting each mark. A door frame inside edge can be used as a guide as shown. Extend the lines about 6" from the rear of the tube.

6

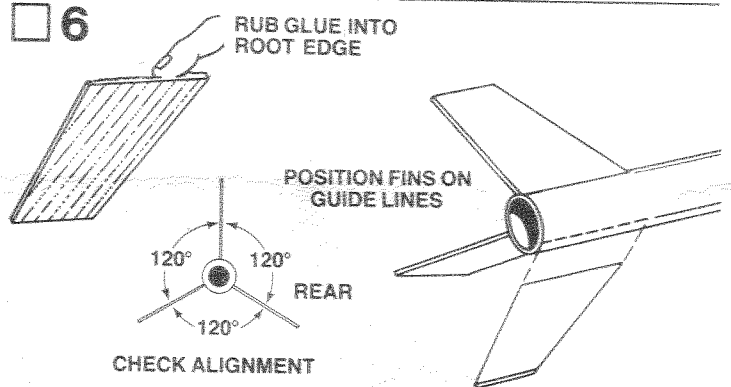

Rub a line of glue into the root edge of each fin and allow to dry. Apply glue to the fins and position fins on the alignment lines in their correct positions on the tube. Refer to the illustration to be sure of these positions. Adjust the fins so they project straight away from the body tube. Do not set the rocket on its fins while the glue is wet.

7

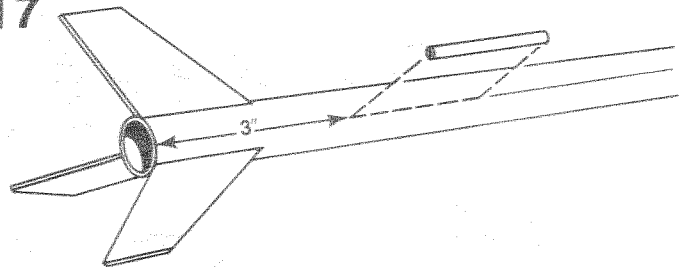

Glue launch lug (part G) to rocket body tube on the launch lug line. The rear of the launch lug should be 3" from the rear of the rocket body tube. Align the launch lug straight along the body.

8

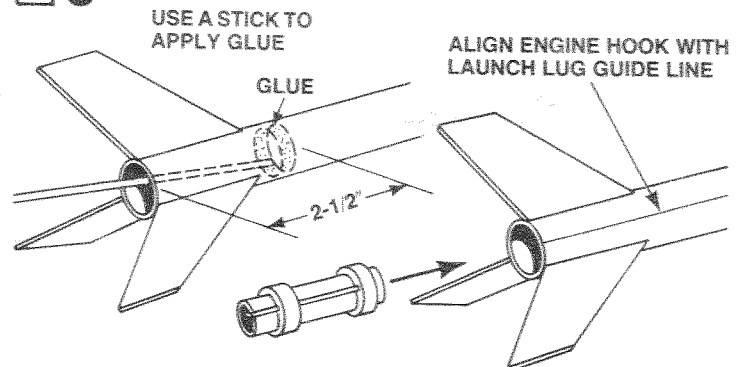

Apply a ring of glue around inside of rear end of body tube about 2" to 2-1/2" from the end of the tube. Use a stick or dowel as shown. Immediately insert the engine mount unit, being careful to position it so the engine hook will stick out of the end of the tube. Push engine mount in with one smooth motion until the end of the engine mount tube and the end of the body tubes are even.

9

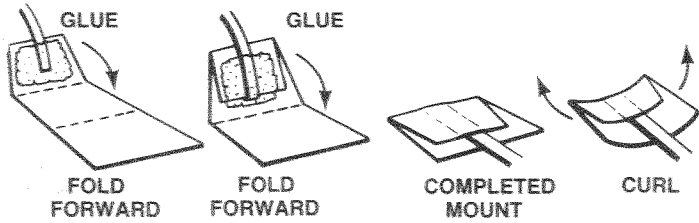

Cut out the shock cord mount from the front page of the instruction sheet. Crease it on the dotted lines by folding. Spread glue on the first section (1) and lay the end of the shock cord (part H) into the glue. Fold over and apply glue to the back of the first section and the exposed part of section 2. Lay the shock cord as shown and fold over again. Clamp the unit together with your fingers until the glue sets.

10

SMEAR A FILM OF GLUE OVER MOUNT AND SURROUNDING AREA INSIDE THE BODY TUBE

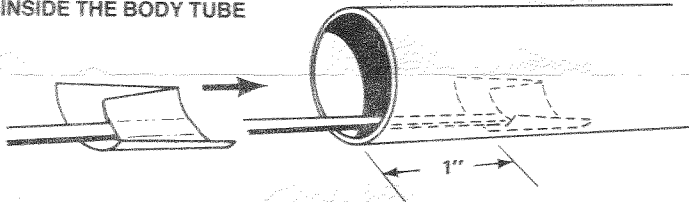

Use a stick or scrap dowel to apply a generous amount of glue inside the body tube 1" from the front of the tube. Slide the shock cord mount into the tube and press it into the glue. To insure a good bond use a stick or your finger to smear a film of glue over the mount and surrounding area in the body tube.

11

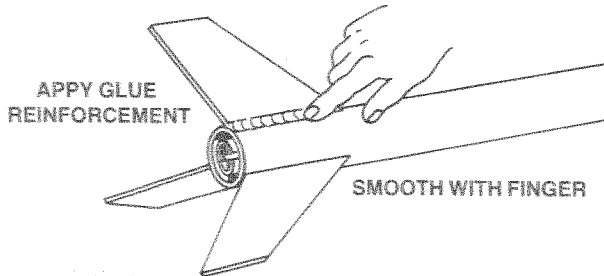

Apply glue reinforcements to each fin/body tube joint. Holding the model level, apply a narrow line of glue to both sides of each fin joint. Smooth out the glue with your finger. Apply glue reinforcement on both sides of launch lug. **IMPORTANT** -- Keep the model level until the glue dries.

12

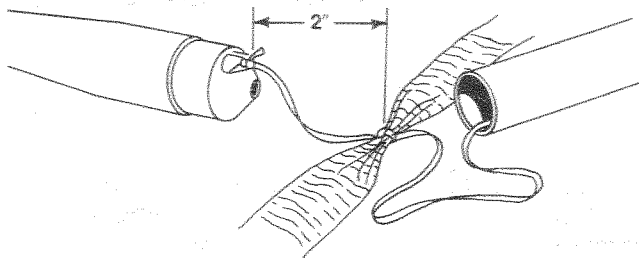

Using a double knot, tie the shock cord around the middle of the plastic streamer (part J) about 2" from the end of the shock cord. Attach the free end of the shock cord to the nose cone with a firm knot.

PAINTING AND DETAILING

13

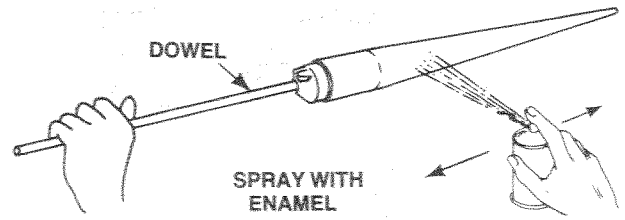

Spray paint the nose cone with several light coats of green paint. The nose cone can be supported by a dowel or stick inserted in the center opening in the nose cone while being painted and drying. A layer of masking tape around nose cone shoulder works well to protect the nose cone shoulder from "overspray" while painting.

14

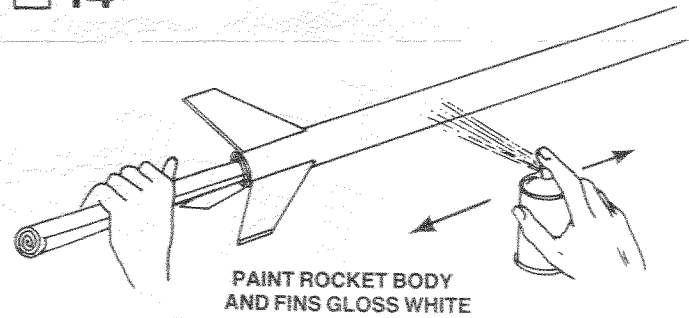

When all glue on the outside of the body is dry, insert a sheet of rolled-up newspaper or heavy paper into rear of rocket body as shown. **THE PAPER MUST FIT TIGHTLY.** Apply two or three light coats of gloss white spray enamel to the model. Allow each coat of paint to dry completely.

DECAL PLACEMENT

15

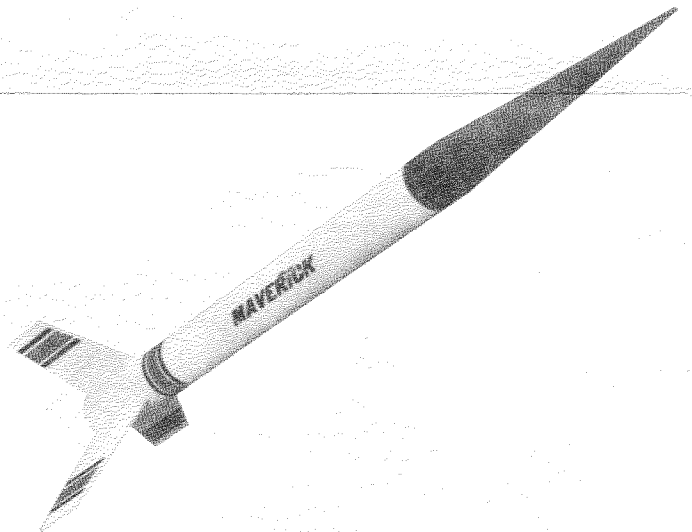

Apply the decals (part K) in the positions shown. Cut out decal, dip in lukewarm water for 10-20 seconds, and hold it until it starts to uncurl. Slip decals into proper positions while slipping backing paper out from under decal. Match up ends of decal and blot away excess water. For best results, let the model dry overnight and apply a coat of clear spray to protect the decal.

LAUNCHING COMPONENTS

To launch your rocket you will need the following items:
 An Estes model rocket launch system
 Parachute recovery wadding (Estes Cat. No. 2274)
 Recommended engines: A8-3, B4-4, B6-4, B8-5, and C6-5.
 Use an A8-3 engine for your first flight.

Be sure to follow the HIAA-NAR* Model Rocket Safety Code when carrying out your model rocket activities.
 *HIAA—Hobby Industry of America
 *NAR—National Association of Rocketry

COUNTDOWN CHECKLIST

T-13

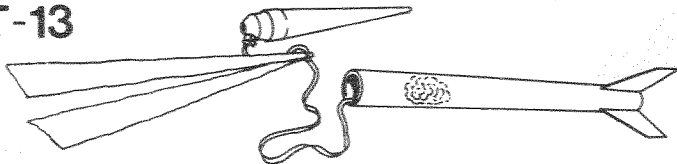

Pack 3 or 4 squares of loosely crumpled recovery wadding into the rocket body.

T-12

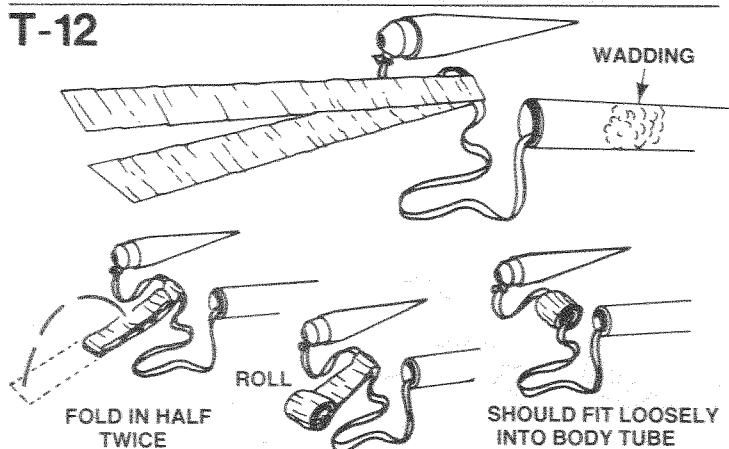

Fold the streamer in half lengthwise. Fold again, then roll until the streamer and shock cord fit loosely into the rocket body. Slide the nose cone into place.

NOTE: Nose cone should separate easily from rocket body tube, but should not be extremely loose. If fit is too tight, sand inside of body tube and shoulder of nose cone with fine sandpaper. If fit is too loose, add a wrapping of transparent tape or masking tape to the shoulder of the nose cone.

T-11

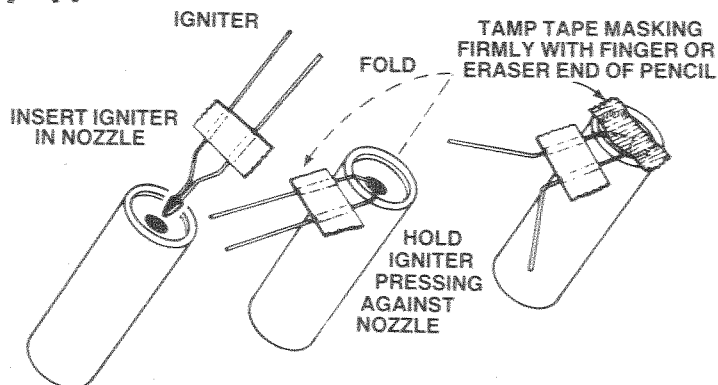

Select an engine and install an igniter as directed in the engine instructions. Use an A8-3 engine for your first flight.

T-10

MAKE SURE ENGINE HOOK LATCHES SECURELY

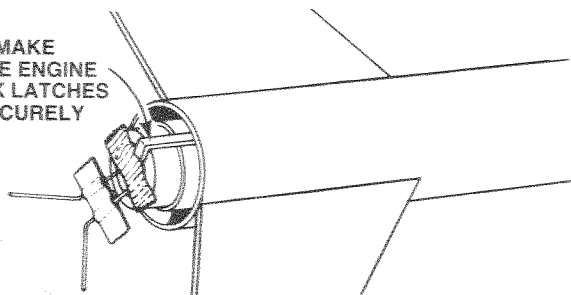

Insert engine into rocket engine mount. Engine hook must latch securely over end of the engine.

T-9

Disarm the launch panel -- REMOVE SAFETY KEY!

T-8

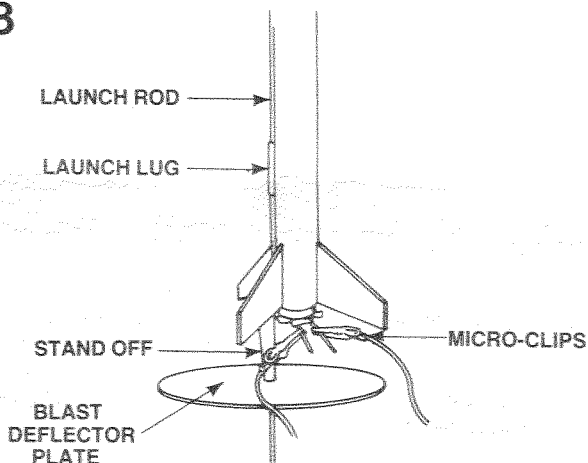

Slide launch rod through rocket launch lug and place rocket on launch pad. Make sure the rocket slides freely on the launch rod. Clean the micro-clips and attach them to the igniter wires. Arrange the clips so they do not touch each other or the metal blast deflector. Attach clips as close to protective tape on igniter as possible.

T-7

Clear the launch area, alert recovery crew and trackers, check for low flying aircraft and unauthorized persons in the recovery area.

T-6

Arm the launch panel -- INSERT SAFETY KEY!

-5-4-3-2-1-LAUNCH!!

Repeat Countdown Checklist for each flight.

MISFIRE PROCEDURE

Disarm the launch panel. Wait one minute before approaching the rocket on the launch pad. Remove the rocket, clean the igniter residue from the nozzle of the engine, and carefully install a new igniter. Repeat the Countdown Checklist.

Failure of the rocket engine to function properly is nearly always caused by a failure to install the igniter correctly. This failure permits the igniter to heat and burn into two pieces without igniting the engine.

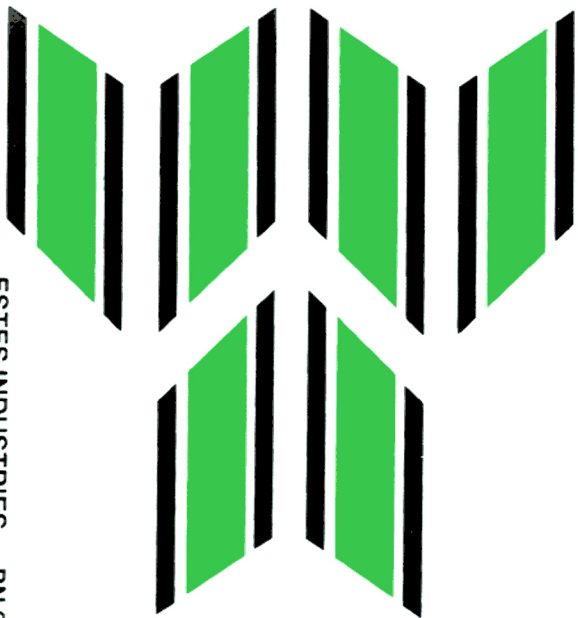

ESTES INDUSTRIES PN 37219

MAVERICK ESTES

