

ORBITAL INTERCEPTOR

SKILL LEVEL 2 – Recommended for Intermediate Rocketeers.

BEFORE YOU START

Read all instructions before beginning work on your model. Make sure you have all parts and materials. When you are thoroughly familiar with the assembly procedure, begin construction. Check off each step as you complete it. In each step, test-fit the parts together before applying any glue. If some part doesn't fit properly, sand lightly or build up as required for precision assembly.

TOOLS AND MATERIALS

In addition to the parts included in this kit you will need: Scissors, white glue (Titebond, Elmer's, or similar), a sharp model knife, pencil, ruler, sandpaper, sanding sealer, masking tape, paint brush, wax paper, a hard back book, dowels, gloss white spray paint and insignia blue spray paint.



A DAMON COMPANY

ESTES INDUSTRIES
PENROSE, CO 81240 USA

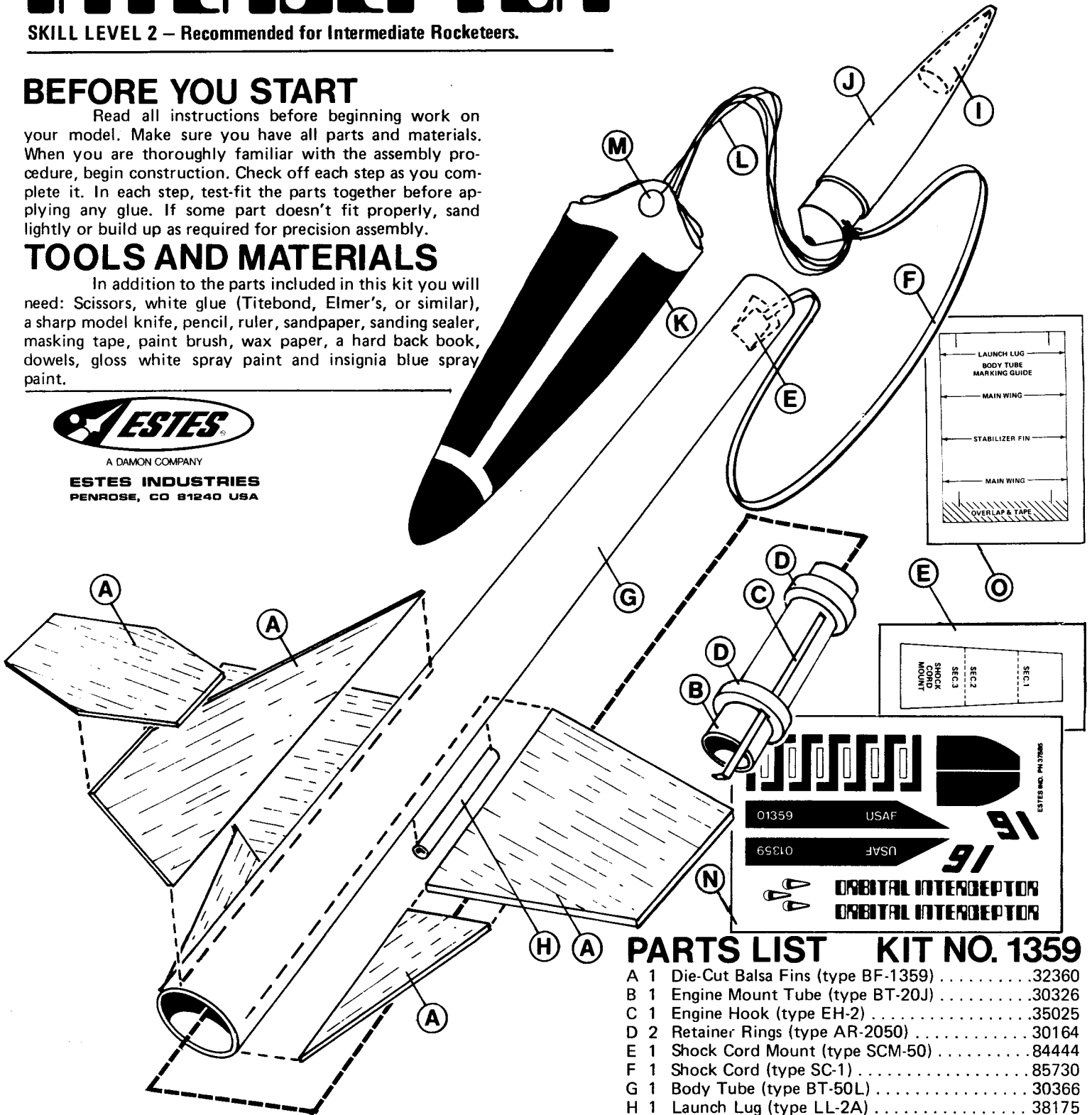

RECOMMENDED ENGINES:
1/2A6-2 A8-3 B4-4 B6-4
B8-5 C5-3 C6-5 C6-7

PARTS LIST KIT NO. 1359

A	1	Die-Cut Balsa Fins (type BF-1359)	32360
B	1	Engine Mount Tube (type BT-20J)	30326
C	1	Engine Hook (type EH-2)	35025
D	2	Retainer Rings (type AR-2050)	30164
E	1	Shock Cord Mount (type SCM-50)	84444
F	1	Shock Cord (type SC-1)	85730
G	1	Body Tube (type BT-50L)	30366
H	1	Launch Lug (type LL-2A)	38175
I	1	Clay Weight	85264
J	1	Nose Cone (type PNC-50Y)	71009
K	1	12" Parachute (type PK-12)	85564
L	1	Shroud Line (type SLT-72)	38237
M	1	Tape Disc S ⁺ (type TD-3F)	38406
N	1	Decal Sheet (type KD-1359)	37585
O	1	Fin Marking Guide	84256

ASSEMBLY INSTRUCTIONS

1

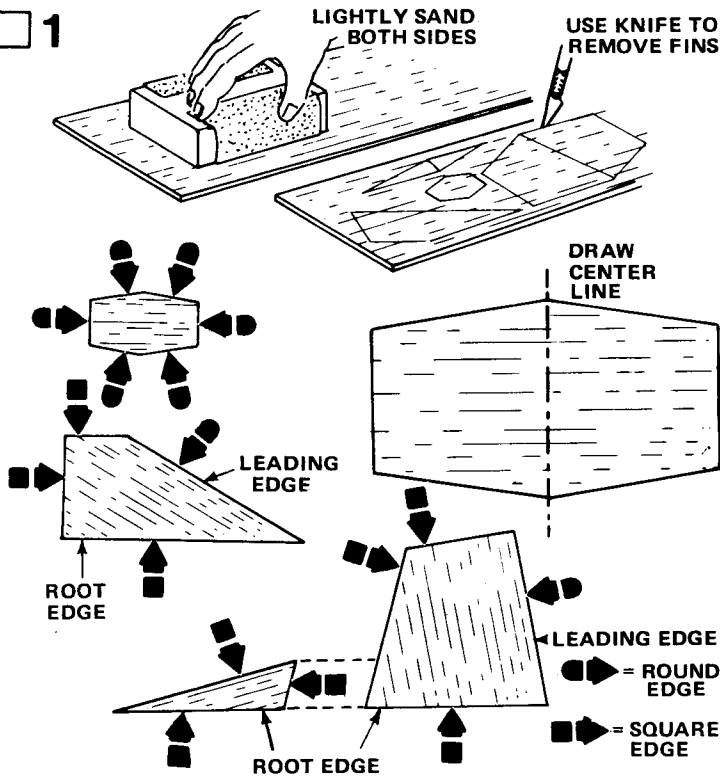

Fine-sand both sides of the balsa fin sheet (part A). Carefully remove the fins from the sheet using a sharp knife to free the corners and edges. Sand round the leading edges of the main wings and the leading edge of the vertical fin as shown. NOTE: The leading edge follows the direction of the grain. Place the horizontal fin on the above drawing. Draw the centerline as shown. Sand round all edges using the centerline as a guide to help prevent over-sanding one of the edges.

2

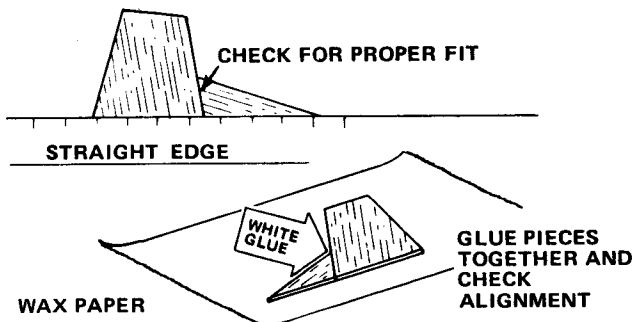

Place the main wings and the trailing sections together on a flat surface. Use a ruler or similar straight-edge to assure proper alignment. The two pieces should be flat along the ruler and fit together snugly. Carefully sand the front edge of the trailing section, if necessary, to obtain proper fit. Once the pieces fit properly, glue them together on wax paper on the flat surface (to prevent gluing the fins to the surface). Again check the alignment and adjust parts if necessary. Let glue dry before handling parts. Repeat procedure with other main wing.

3

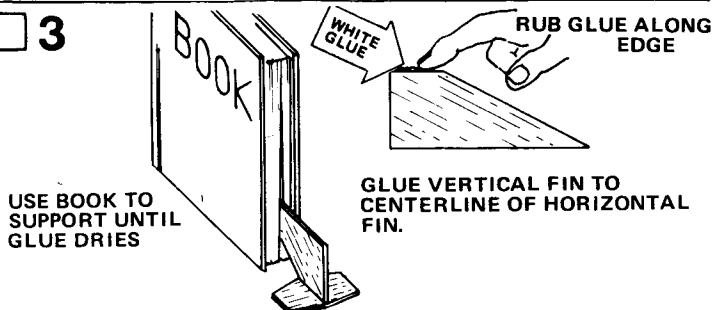

STEP 3 CONTINUED

Glue the vertical fin over the centerline of the horizontal fin. Place the horizontal fin on a flat surface. Use a hardback book to make sure the vertical fin is straight up and down as shown in the illustrations. Allow the glue to dry before handling the fins.

4

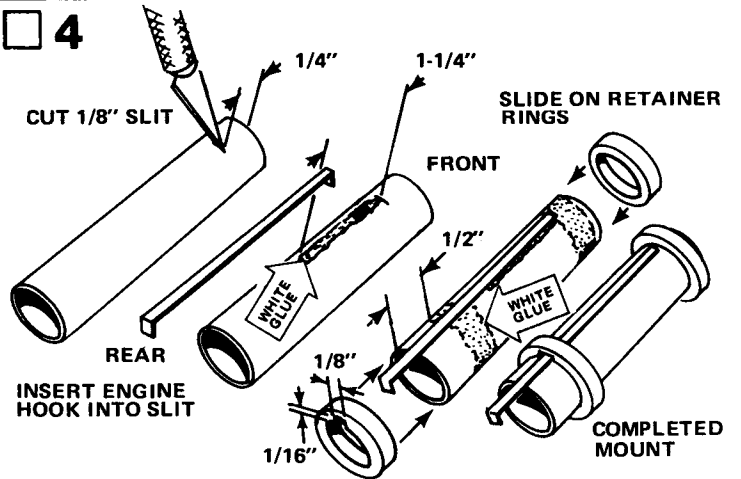

Cut a 1/8" long slit in the engine mount tube (part B), 1/4" from one end as shown. Apply a 1-1/4" line of glue straight along the tube as shown. Push one end of the engine hook (part C) into the slit and press the main part of the hook into the glue. Glue one retainer ring (part D) to the engine mount tube against the engine hook as shown. Cut a groove on the inside of the other retainer ring 1/8" wide and 1/16" deep as shown. Glue the retainer ring on the engine mount tube 1/2" from the rear end (the end with the over-hanging hook) so the groove is over the engine hook. Set the completed unit aside until the glue is dry.

5

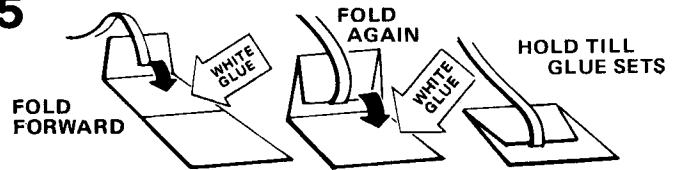

Cut out the shock cord mount (part E). Crease it on the dotted lines by folding. Spread glue on section 1 and lay one end of the shock cord (part F) into the glue. Fold over and apply glue to the back of section 1 and the exposed part of section 2. Lay the shock cord as shown and fold over again. Clamp the unit together with your fingers until the glue sets.

6

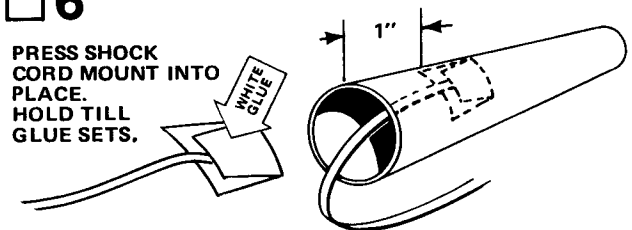

Smear glue over the entire backside of the shock cord mount. Hold the mount as shown and press it into place inside one end of the rocket body tube (part G). Make sure the front of the mount is at least 1" from the end of the tube. Hold the mount in place until the glue sets.

7

SMEAR GLUE WITH STICK OR DOWEL

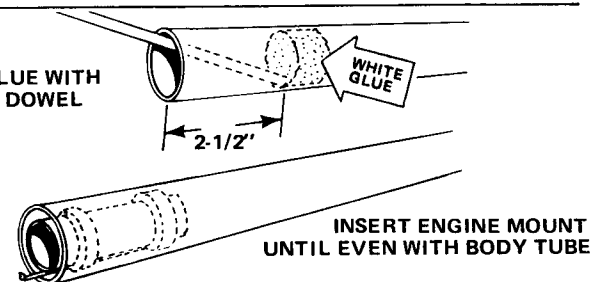

STEP 7 CONTINUED

Apply a ring of glue around inside of rear end of body tube about 2" to 2-1/2" from the end of the tube. Push the engine mount in with one smooth motion until the engine tube and the body tube are even.

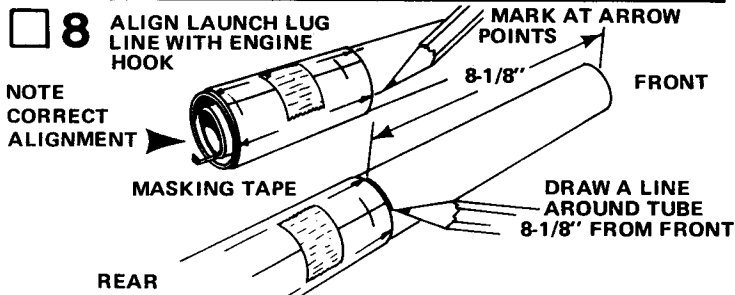

Carefully cut out the fin marking guide (part O) from back of the panel. Wrap the guide around the rear of the tube. Match the printed alignment marks, align the launch lug line with the engine hook, and tape the ends together. Mark all guide lines on the body tube. Using the front edge of the guide, draw a line around the body tube 8-1/8" from the front. Remove the guide.

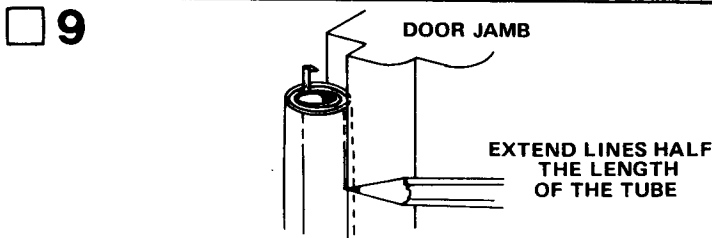

Place the body tube against the inside edge of a door frame as shown. Extend a line from the rear of the tube through each mark half-way along the tube.

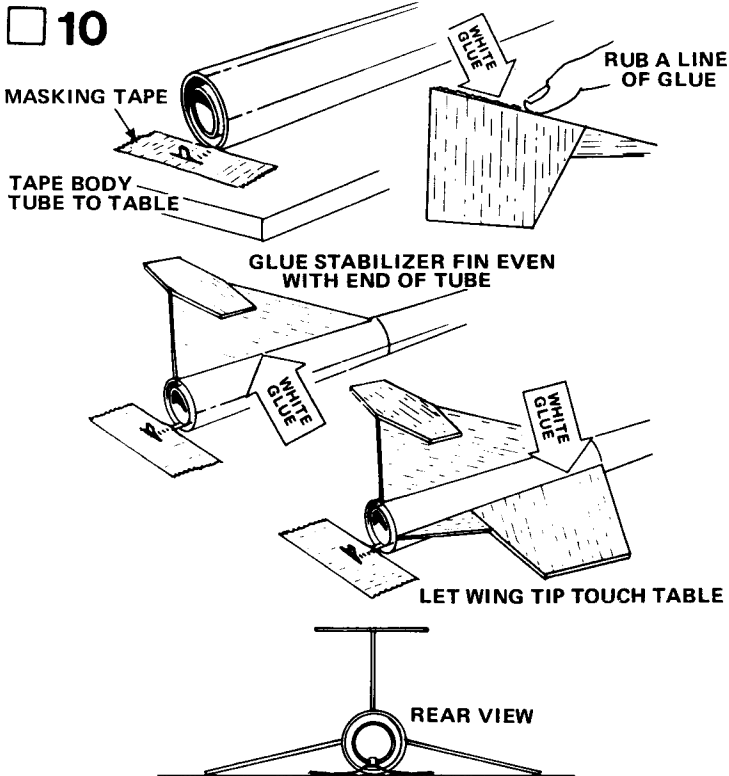

Rub a line of glue into the root edge of each fin unit. Allow glue to dry. Place the body tube on a flat surface and tape down the engine hook as shown. Use a small piece of masking tape extending from the front of the body tube to hold it down securely. Glue the stabilizer fin to the top guide line so that the rear of the fin is at the end of the body tube. Adjust the fin so that it projects straight up. Hold in place until the glue sets. Glue the main wings to the body one at a time. Glue the wing on the guide line so that the

rear of the wing is even with the rear of the body tube. After the glue has become tacky, allow the wing to droop and touch the table as shown. Make sure the wing has not slipped off of its guide line. Glue the other wing on using the same method. Allow the glue on the wings to dry completely before removing the rocket from the flat surface. Remove and discard the two pieces of masking tape. Sand off any overhang on tip of trailing section so it is flush with the tube.

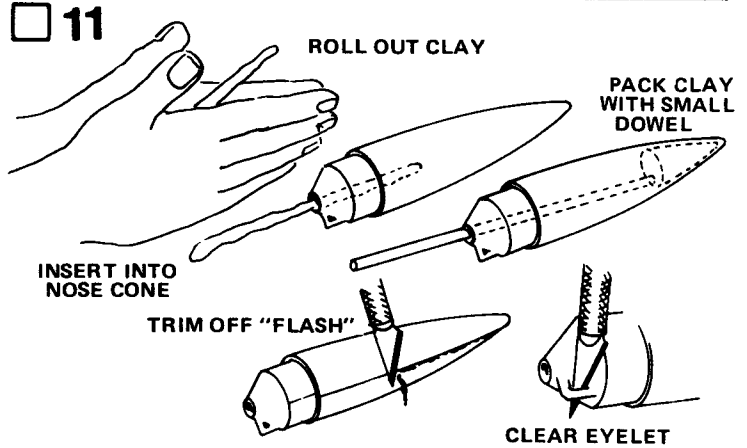

Roll the clay weight (part I) into several long thin sections with your hands. Push each piece through the hole in the rear of the nose cone (part J). Pack the clay firmly and evenly in the tip of the nose cone using a balsa strip or other similar object. Be certain the clay is packed firmly. Trim or sand any excess plastic from around the sides of the nose cone. Use a sharp knife to remove any excess plastic from the inside of the molded eyelet at the rear of the nose cone. Wash the nose cone with lukewarm soapy water, rinse, and let dry.

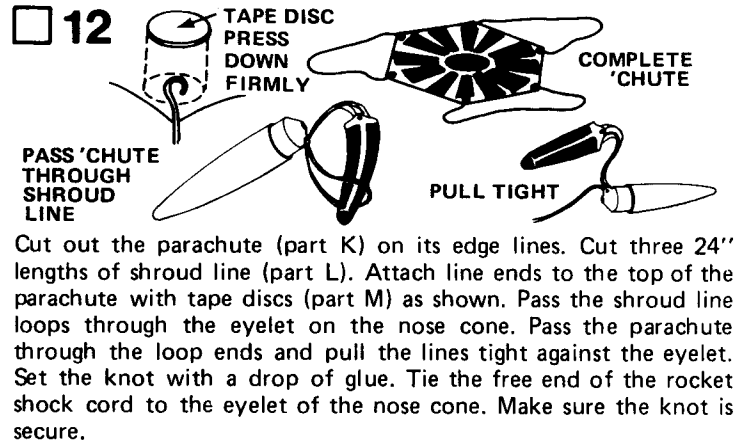

Cut out the parachute (part K) on its edge lines. Cut three 24" lengths of shroud line (part L). Attach line ends to the top of the parachute with tape discs (part M) as shown. Pass the shroud line loops through the eyelet on the nose cone. Pass the parachute through the loop ends and pull the lines tight against the eyelet. Set the knot with a drop of glue. Tie the free end of the rocket shock cord to the eyelet of the nose cone. Make sure the knot is secure.

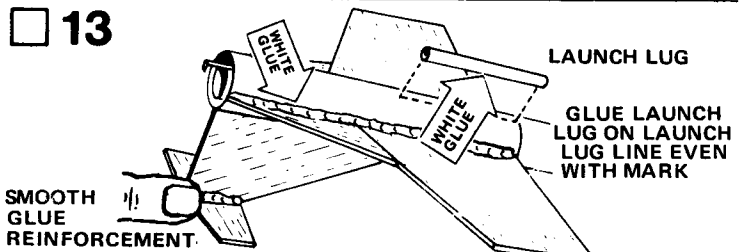

Glue the launch lug (part H) along the launch lug line so that the front of the lug is at the forward guide mark drawn in Step 8. Make sure the launch lug is aligned straight along the body tube. Apply a glue reinforcement to each fin joint. Holding the model level, apply a line of glue to both sides of each joint. Smooth out the glue with your finger. Keep the model level until the glue dries.

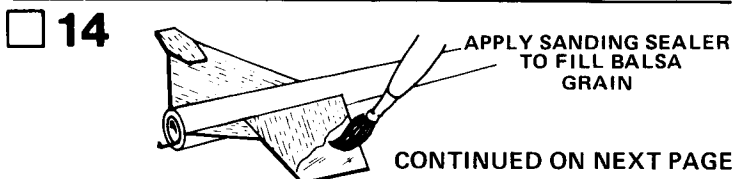

CONTINUED ON NEXT PAGE

STEP 14 CONTINUED

SAND LIGHTLY UNTIL SMOOTH

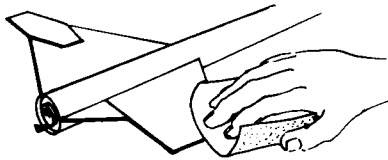

When all the glue on the model is dry prepare the balsa fins of the model for painting. Apply at least two coats of sanding sealer to all balsa surfaces. Let dry and sand thoroughly with extra-fine sandpaper after each coat. Do this until the tiny grain lines in the wood are filled and everything looks and feels smooth.

15

INSERT DOWEL TO HOLD ROCKET WHILE PAINTING

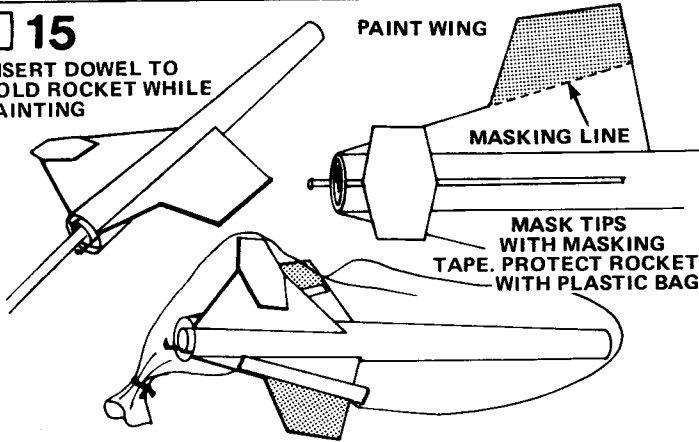

Use a wood dowel or similar object inserted in the rear of the rocket to hold it while painting. Spray the entire rocket with several light coats of gloss white spray paint. After this paint has thoroughly dried, mask off the wing tips on the top and bottom as shown. Paint the tips insignia blue. Carefully remove the masking tape and plastic bag from the model.

16

DIP DECAL FOR 10-20 SECONDS

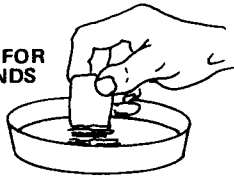

HOLD DECAL UNTIL IT BEGINS TO UNCURL



Apply the decals (part N) in the positions shown on the package panel. To apply decals, cut out a decal section and dip it in luke-warm water for 10-20 seconds. Hold decal until it starts to uncurl or slides easily on the backing sheet. Use a small brush to wet the model surface where the decal will be applied. Slide decal off the backing sheet and onto the model. Position the decal and blot away excess water with a damp cloth. Allow decaled model to dry overnight. Apply a final light coat of gloss clear spray enamel over decaled areas to protect the decals.

LAUNCHING COMPONENTS

To launch your rocket you will need the following items:

- An Estes model rocket launch system
- Parachute recovery wadding (Estes Cat. No. 2274)
- Recommended engines: 1/2A6-2, A8-3, B4-4, B6-4, B8-5, C5-3, C6-5, and C6-7. Use an A8-3 engine for your first flight.

IMPORTANT:

Be sure to follow the *HIAA-NAR Model Rocket Safety Code when carrying out your model rocket activities.

*HIAA -- Hobby Industry Association of America
NAR -- National Association of Rocketry

COUNTDOWN CHECKLIST

T-14



Pack 4 squares of loosely crumpled recovery wadding into the rocket body.

T-13

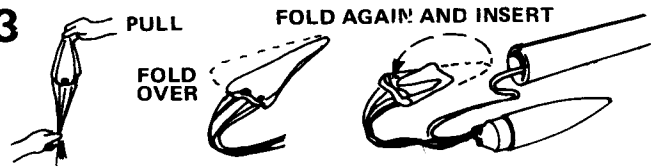

Gather the parachute as shown, then fold into a triangular shape. Fold again and insert into rocket body.

NOTE: DO NOT pack parachute until you are actually ready to launch. For maximum parachute reliability, lightly dust the 'chute with ordinary talcum powder before each flight, especially in cold weather.

T-12

Pack parachute, shroud lines, and shock cord neatly into rocket body. Slide nose cone into place.

Nose cone should separate easily from rocket body tube, but should not be extremely loose. If fit is too tight, sand inside of body tube and shoulder of nose cone with fine sandpaper. If fit is too loose, add a wrapping of transparent tape or masking tape to the shoulder of the nose cone.

T-11

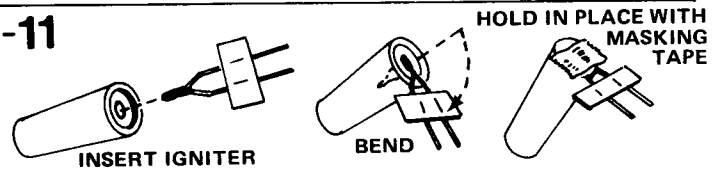

Select an engine and install an igniter as directed in the engine instructions. Use an A8-3 engine for your first flight.

T-10

LATCH ENGINE HOOK SECURELY

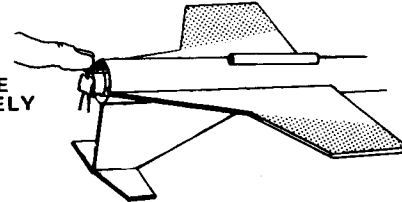

Insert engine into rocket engine mount. Engine hook must latch securely over end of engine.

T-9

Disarm the launch panel -- REMOVE SAFETY KEY!

T-8

SPENT ENGINE CASING OR STAND-OFF

BLAST DEFLECTOR

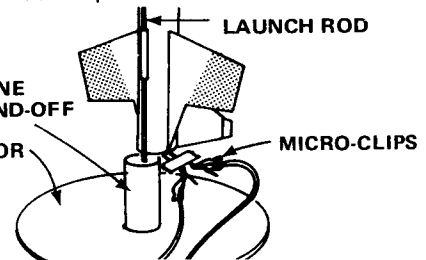

Slide launch rod through rocket launch lug and place rocket on launch pad. Make sure the rocket slides freely on the launch rod. This model requires a stand-off. Clean the micro-clips and attach them to the igniter wires. Arrange the clips so they do not touch each other or the metal blast deflector. Attach clips as close to engine as possible.

T-7

Clear the launch area, alert recovery crew and trackers. Check for low flying aircraft and unauthorized persons in the recovery area.

T-6

Arm the launch panel -- INSERT SAFETY KEY!

-5-4-3-2-1-LAUNCH!!

Repeat Countdown Checklist for each flight.

MISFIRE PROCEDURE

Occasionally the igniter will heat and burn into two pieces without igniting the engine. This is almost always caused by a failure to install it correctly. REMOVE SAFETY KEY from launch panel, remove the model, clean the igniter residue from the engine nozzle, and install a new igniter. Repeat the Countdown Checklist.

1

2

3

4

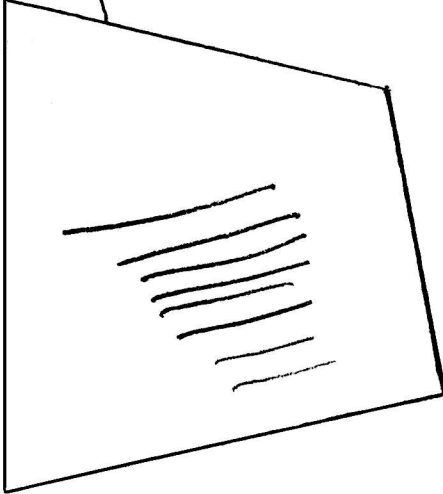
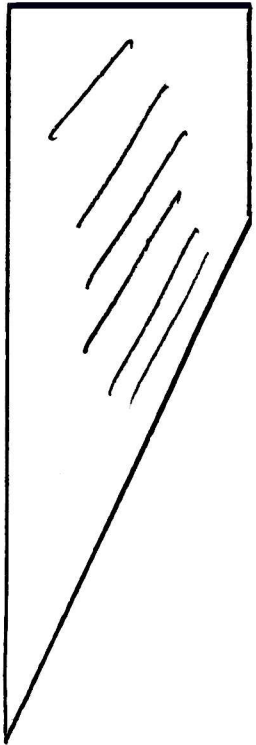
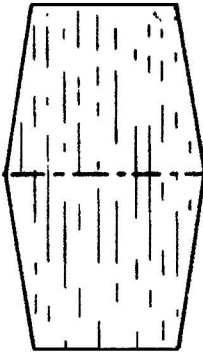

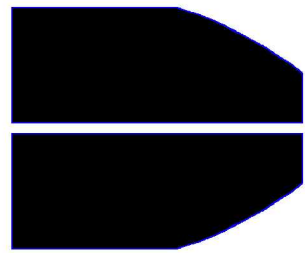
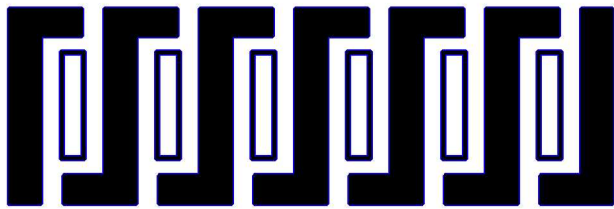

01359

USAF

01359

USAF

16 16

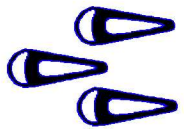

ORBITAL INTERCEPTOR

ORBITAL INTERCEPTOR



ESTES NO. PN 37585