

# STAR WARS™

## Imperial **T.I.E. Fighter**™

## FLYING MODEL ROCKET

SKILL LEVEL 3

1—Beginner 2—Intermediate 3—Craftsman  
4—Advanced 5—Expert

Flights up to  
300 Feet!

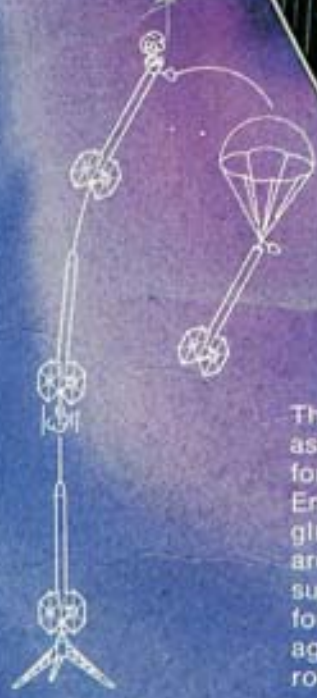

Primary attack craft of the Imperial Forces commanded by Darth Vader. Kit features include highly detailed, pre-colored plastic cockpit and fuselage, quick-release engine mount, and big 18" recovery ' chute. Special parachute recovery probe attaches quickly for flight and removes easily for display.

This is a hobby kit requiring assembly. Recommended for ages 10 to adult. Engines, launch system, glue and finishing supplies are not included. Adult supervision is suggested for those under 12 years of age when flying model rockets.

### Specifications:

Display Length: 5.4" (13.7 cm)  
Wing Span: 5.0" (12.7 cm)  
Flying Length: 21.0" (53.2 cm)  
18" Parachute Recovery

Recommended Engine: C6-3



A SUBSIDIARY OF DAMON

ESTES INDUSTRIES  
PENROSE, COLO. 81240 U.S.A.



# PARTS LIST

A)	1	Fuselage .....	33199
B)	2	Inside Wing Hub .....	33193
C)	2	Outside Wing Hub .....	33191
D)	2	Wing (2 halves per sheet) .....	34000
E)	1	Rear Hatch Hinge .....	33197
F)	2	Laser Cannon .....	33196
G)	1	Cockpit Window .....	33195
H)	2	Wing/Fin Attachment Post .....	33198
I)	1	Engine Tube (type BT-20DJ) .....	30332
J)	1	Engine Holder (type EH-2) .....	35025
K)	1	Strapdown Ring (type HR-20) .....	30168
L)	1	Centering Ring (type AR-2050) .....	30164
M)	1	Split Centering Ring (type AR-2050S) .....	80425
N)	1	Body Tube (type BT-50TF) .....	30369
O)	1	Balsa Die-Cut Sheet .....	32306
P)	1	Launch Lug (type LL-2B) .....	38178
Q)	1	Screw Eye (type SE-2A) .....	38252
R)	2	Weight (type NCW-1A) .....	38280
S)	1	Nose Cone (type BNC-50J) .....	70256
T)	1	Pattern Sheet (Not Shown) .....	84065
U)	1	Shock Cord (type SC-1) .....	85730
V)	2	Mounting Screws .....	45138
W)	1	Shroud Line (type SLT-108) .....	38239
X)	1	Tape Discs (type TD-3F) .....	38406
Y)	1	Parachute (type PK-18A) .....	85566

# STAR WARS

## T.I.E. Fighter

### KIT NO. 1299

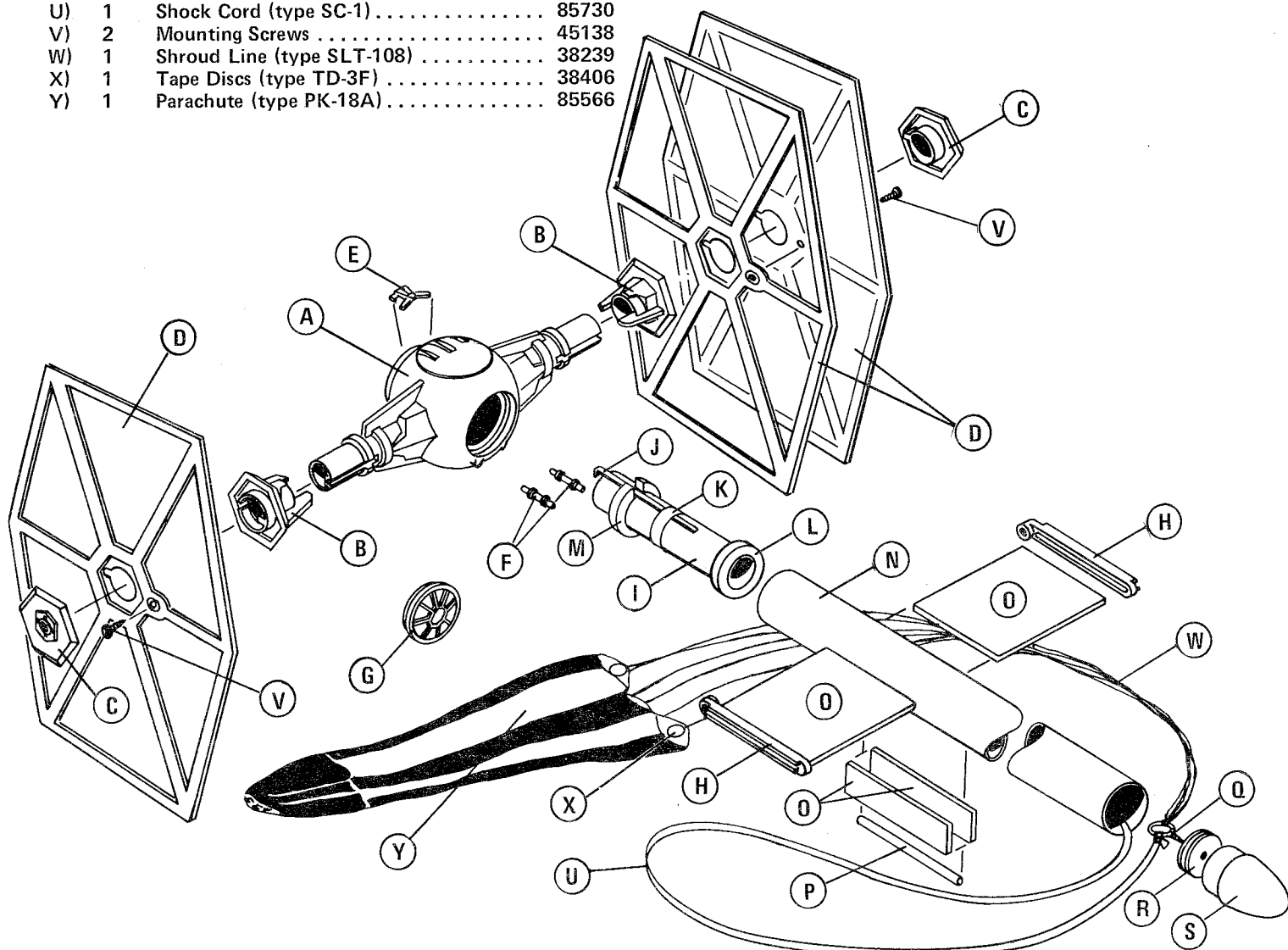

#### MATERIALS NEEDED TO COMPLETE THIS KIT

1. Modeling knife with sharp blade.
2. Ruler.
3. Pencil.
4. Fine (#320-#400 grit) sandpaper.
5. Liquid plastic cement "in a bottle" (do not substitute tube-type plastic model cement for this).
6. Household "white glue" for gluing wood or all porous materials.
7. Masking tape.
8. Balsa filler coat or sanding sealer.
9. Small (#1-#2) brush.
10. Enamel paint, refer to step 26 for colors needed.



A SUBSIDIARY OF DAMON  
**ESTES INDUSTRIES**  
 PENROSE, COLO. 81240

# T.I.E. Fighter Assembly

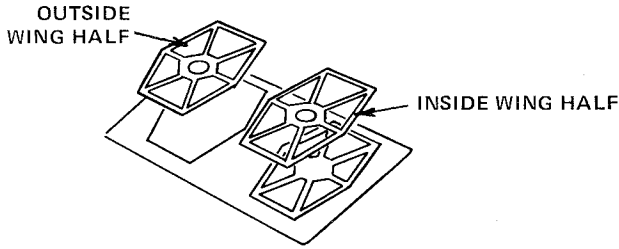

**1** Remove wing halves from one wing sheet (part D). Use a knife to free the parts from the sheet. Note that one wing half has the area between the ribs cut out to reduce weight. This will be called the inside wing half.

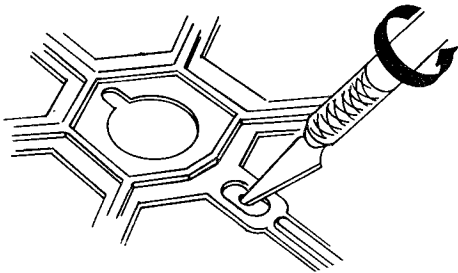

**2** In each wing half there is a recessed area near the center hole. Insert the tip of a modeling knife into the middle of the recess. Twist the knife to make a small hole. The hole must be **ONLY LARGE ENOUGH** to insert the shank of a mounting screw (part V).

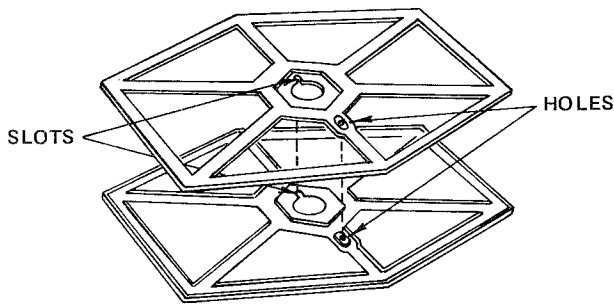

**3** Put the two wing halves together, back to back. Make sure the mounting holes and the slots in the center holes are lined up. Match up the edges and tape the halves together at the top and bottom.

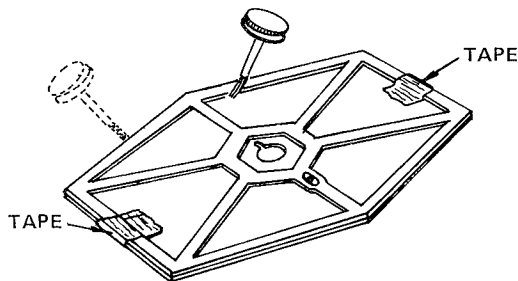

**4** Apply liquid plastic cement around the edges of the inside wing half where it contacts the outside wing half. **DO NOT** apply cement near the tape. If cement flows beneath the tape it may mar the surface when the tape is removed.

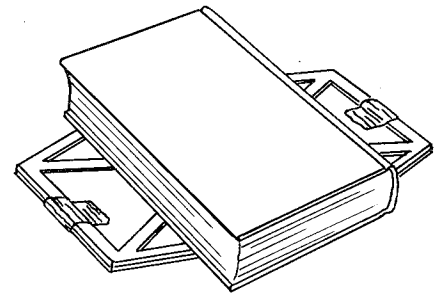

**5** Place the wing on a flat surface and apply weight with a book. Allow to dry 10 minutes, remove weight and peel away tape. Apply cement to the areas where the tape was attached and weight again. When the cement has dried, check the wing to make sure all edges are thoroughly glued. Apply cement to any areas you have missed.

**REPEAT STEPS 1 THRU 5 WITH THE REMAINING WING HALVES.**

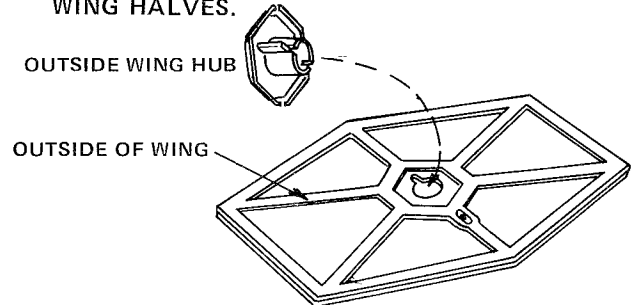

**6** Locate one outside wing hub (part C) and one inside wing hub (part B). Fit the outside hub to the outside of the wing. The round flange on the back of the hub fits through the hole in the wing. A rib on this part passes through the slot in the wing. If the flange does not fit through the hole, remove hub and sand the edges of the wing opening until a fit is obtained. Cement the hub to the wing with liquid plastic cement.

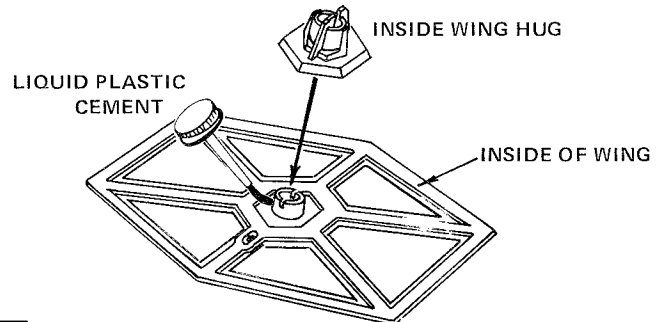

**7** Turn the wing over. Apply liquid plastic cement to the protruding flange of the outside wing hub and press the inside hub into place. Note that a rib in the rear of the inside hub fits into a slot in the outside hub flange. Apply more liquid cement around the base of the inside hub to firmly attach it to the wing. Lightly sand edges of wing.

**REPEAT STEPS 6 AND 7 WITH THE REMAINING WING AND HUBS.**

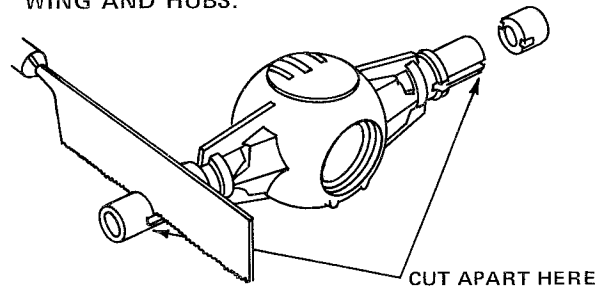

**8** Locate the fuselage (part A). Using a knife or razor saw, cut off the excess material at either end of the part. Two small grooved rings in the plastic locate the cut off points.

end of the hub against the raised ring on the fuselage. If they do not, check the fit of the rib in the groove. If there is interference, lightly sand the end of the rib until the parts fit correctly. Apply liquid plastic cement to the end of the fuselage molding and push the parts together. Apply more cement around joint and let dry. Repeat with remaining wing.

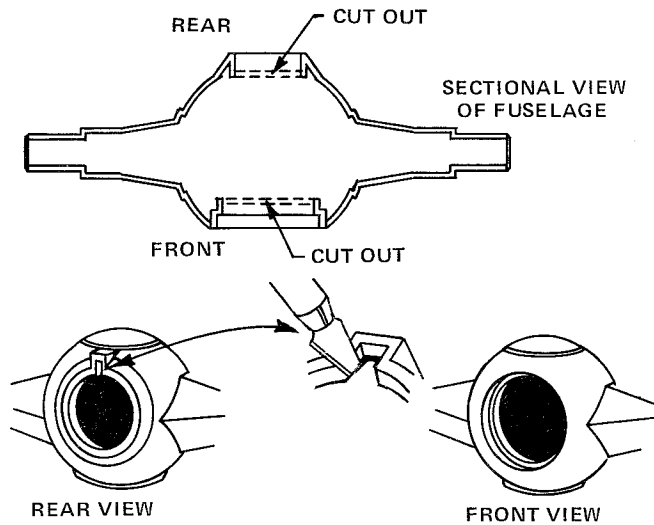

**9** Carefully study the illustrations showing the cut-out areas in the front and rear of the fuselage. The circular cut-out in the front of the fuselage is cut along the bottom of the inner-most ring. The circular cut-out in the rear of the fuselage is cut along the bottom of the inside ring. In addition, the bottom of the notch in the rear opening is cut out to clear the engine holder.

Cut these areas out carefully. Use a sharp knife and make several light cuts rather than one heavy cut. In cutting out the rear opening, cut out the notch first. Be very careful - the plastic is thin. Lightly sand the inside of the openings to eliminate any ragged edges.

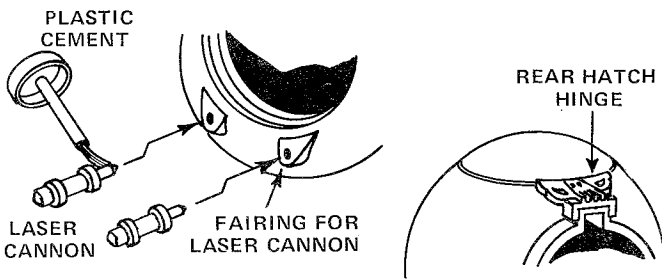

**10** Locate the two laser cannon (part F) and the rear hatch hinge (part E). Insert the point of a knife into the dimple of each laser fairing. Make a hole large enough for the small end of the cannon to fit into. Cement the cannon in place, making sure they extend straight from the fuselage. Cement the hinge detail piece onto the top of the raised area on the fuselage rear.

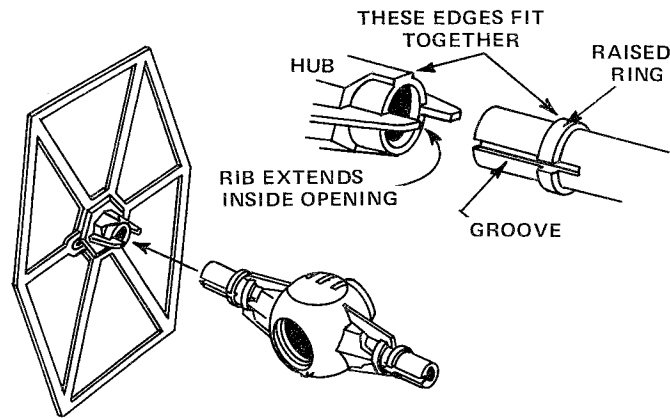

**11** Fit one of the wings to the fuselage. DO NOT cement yet. Note that one of the standing ribs on the wing hub extends down inside the hole in the hub. This rib matches a groove in the fuselage molding. The parts should fit together with the

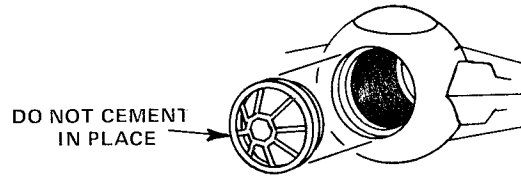

**12** Insert the cockpit window (part G) into the opening in the fuselage front. DO NOT cement this part in place. It is for display only and must be removed when the rocket body is attached for actual flight.

THIS COMPLETES THE BASIC ASSEMBLY OF THE T.I.E. FIGHTER.

## Rocket Body Assembly

The rocket body is attached to the T.I.E. Fighter for actual flight. It is held in place with two mounting screws and may be easily removed for static display of the T.I.E. Fighter.

NOTE: With the exception of step 17, use a household wood (white) glue for all rocket body assembly steps.

The drawing at right is a full size view of the engine tube assembly. Lay the engine tube over the drawing and, using a straight edge, mark the location of various components.

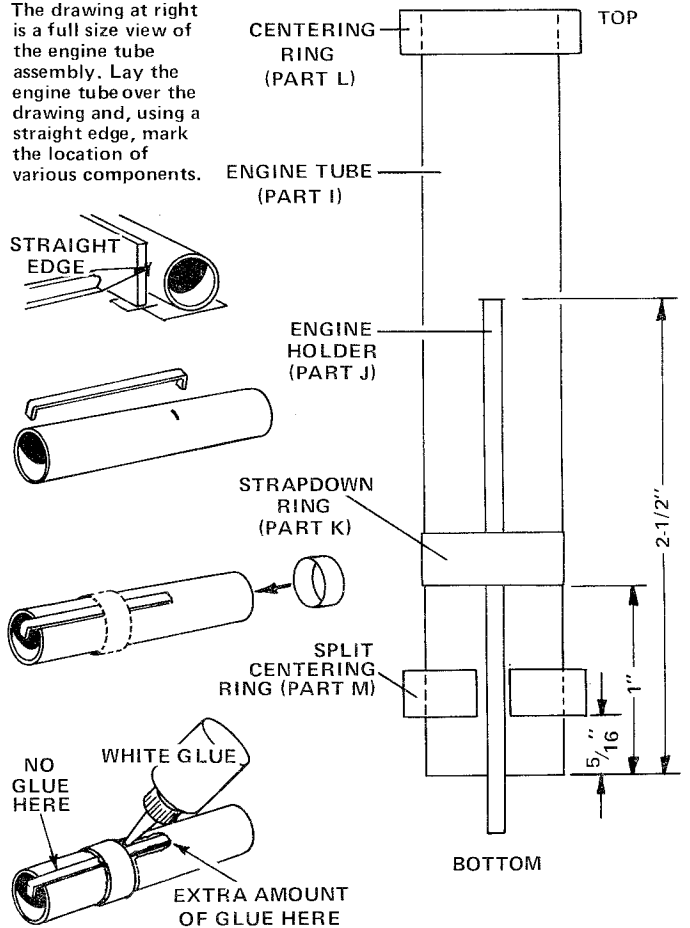

**13** Cut a 1/8" wide slit in the engine tube 2-1/2" from bottom end. Insert one end of engine holder into slit. Slide strapdown ring down over tube to within 1" of bottom. Apply bead of white glue to both sides of ring and upper portion of holder. Smear glue to even film and let dry.

**SAND INSIDE EDGE**

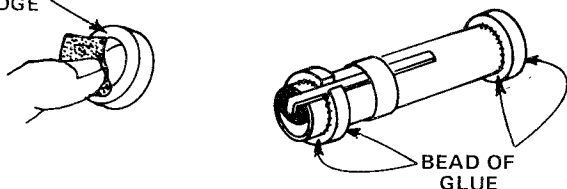

**14** The centering rings often have a small flange on the inside edges. Lightly sand these inside edges so the rings slip easily onto the body tube. Glue the split ring in place 5/16" from the bottom of the tube (don't get glue on the engine holder). Glue the other ring in place flush with the top of the tube. Apply a bead of glue to the area where the centering rings join the engine tube. **LET DRY THOROUGHLY** before proceeding with next step.

**LIGHTLY SAND FOR FIT**

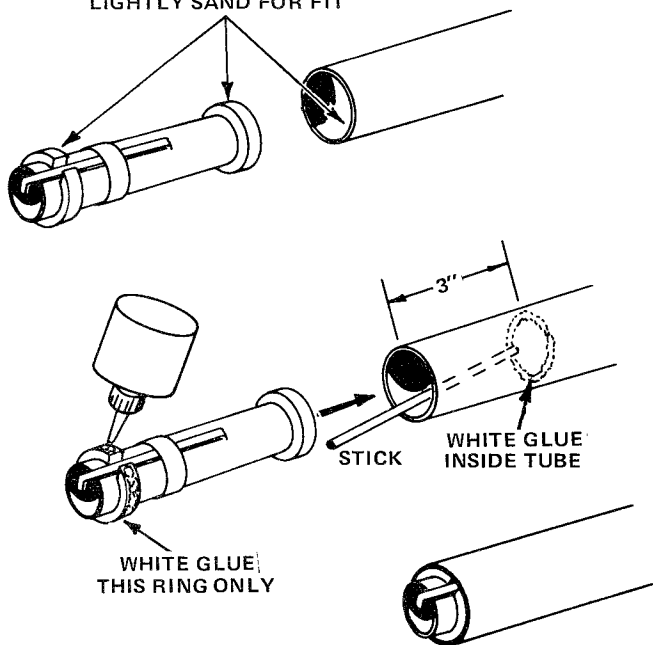

**15** Locate the body tube (part N). Slide the engine tube assembly into the body tube to check fit. If tight, lightly sand the inside edge of the body tube and the outside surfaces of the centering rings. Make sure the parts fit easily before proceeding. Apply a generous bead of white glue around the inside of the body tube, 3" from the end. Use a stick or pencil to do this. Apply white glue to the outside of the **BOTTOM** centering ring. In one smooth motion, slide the engine assembly into the body tube until the bottom centering ring is flush with the end of the body tube. Wipe away excess glue and set aside to dry.

**TOP EDGE**

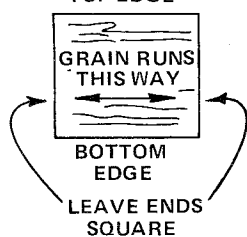

**ROUND TOP & BOTTOM EDGES**

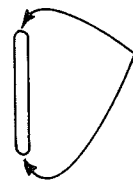

**16** Using a knife, free the balsa parts from the die-cut sheet (part O). The two large square pieces are the fins. The two smaller pieces form the launch lug stand-off. Lay the fins out as shown and sand the top and bottom edges round. Leave the ends square. Lightly sand the sides of the fins.

**ROUNDED EDGES**

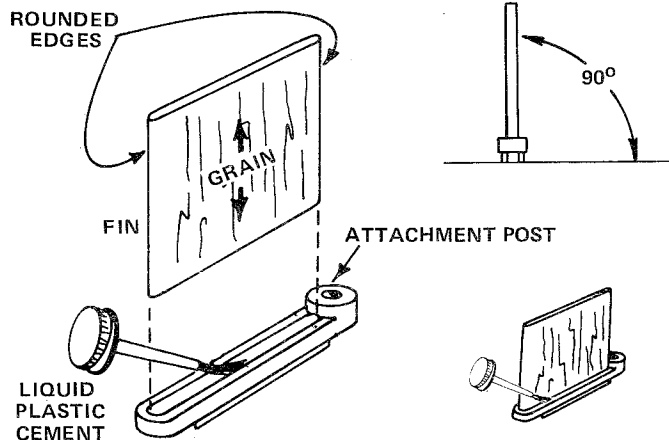

**17** Use liquid plastic cement for this step. Locate the two wing/fin attachment posts (part H). Place the posts on a flat surface with the side up as shown here. Flow a generous amount of cement into the groove. Allow this to set for a couple of minutes then push the end of a fin into the groove. Push firmly to get a good bond. Apply more liquid cement to the sides of the joint. Check by eye to make sure the fin extends straight up from the post. Set aside to let dry for at least 2 hours before disturbing.

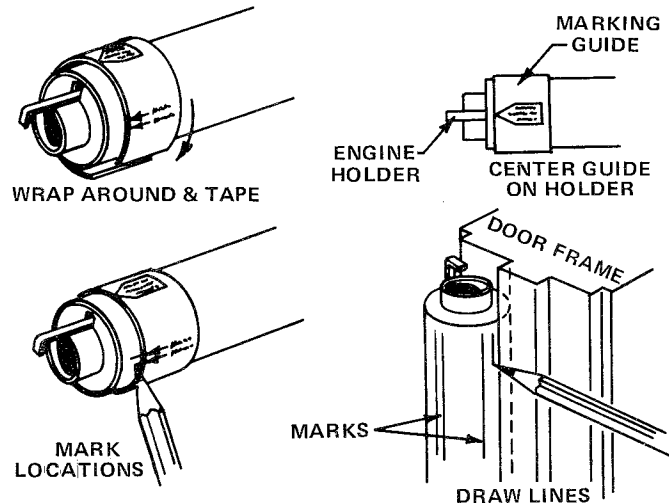

**18** Cut the marking guide from the printed sheet (part T). Wrap around bottom end of body tube and tape ends together. Turn the guide on the tube until the indicated point lines up **EXACTLY** with the center of the engine holder. Mark the locations for the fins and launch lug stand-off. Remove guide. Place the tube against the inside edge of a door frame. Line up each mark with the edge of the wood and draw a line along the tube for about 6". Do this for all six lines.

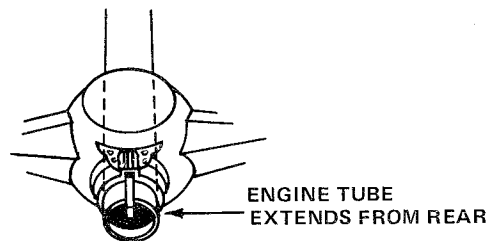

**19** Push the bottom of the body thru the opening in the fuselage. The body must slide in with the engine holder centered in the notch in the rear of the fuselage. The engine tube should extend slightly from the rear of the fuselage. Place tape around bottom of tube to temporarily hold in place.

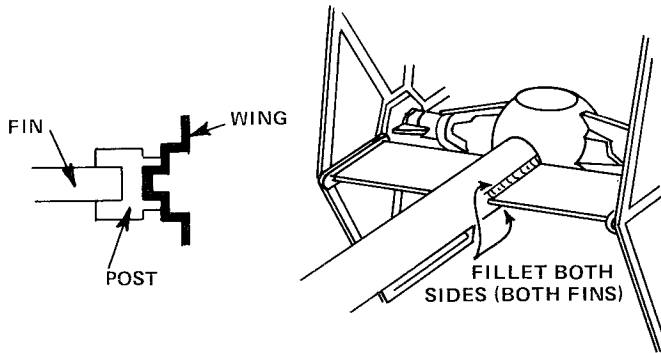
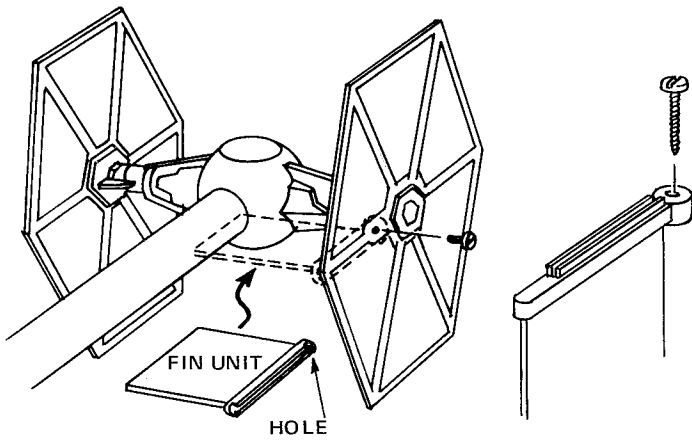

□ **20** Thread a mounting screw (part V) part way through the hole in each attachment post of the fin assemblies. Remove screws. Slide one of the fin assemblies into place as shown. If it does not fit exactly, don't force it. Lightly sand the end of the fin until a fit is obtained. Thread a mounting screw through the wing and into the mounting post. Repeat with remaining fin assembly. Position ends of fins between lines drawn on body tube. Carefully apply a bead of white glue to one side of each fin/body tube joint. Allow to dry 10 minutes, turn rocket over, and apply glue to other side of fin/body tube joints allow to dry thoroughly, then apply more glue to joints and smooth into even fillet with your finger when dry, remove screws and separate rocket from T.I.E. Fighter.

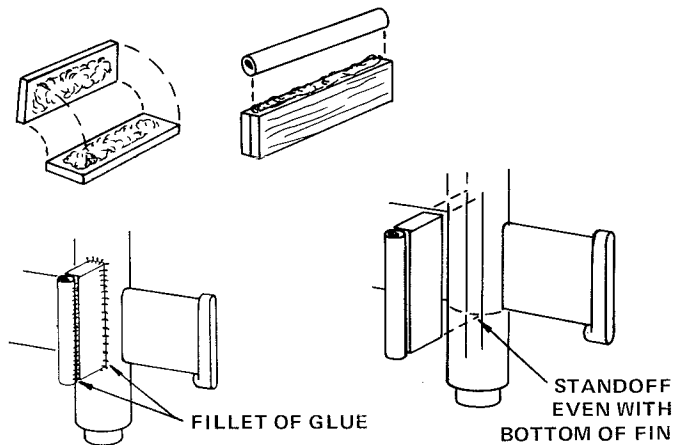

□ **21** Locate the balsa stand-off pieces (previously removed from die-cut sheet). Apply white glue to one side of each piece. Put the pieces together, square up, and weight with a book until dry. Note: The balsa grain on these parts runs different directions for added strength. When dry, sand sides and edges of stand-off smooth and square. Apply glue to one edge and attach launch lug (part P). Let dry. Apply glue to opposite edge and attach to body, using the guide lines to insure unit is parallel to body. After the glue has dried, apply a fillet of glue to both sides of the body and launch lug joints.

APPLY  
SANDING  
SEALER

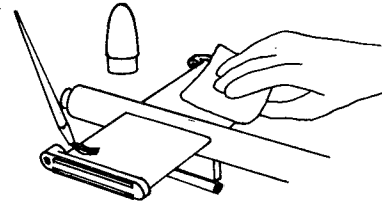

□ **22** Locate the nose cone (part S). Apply sanding sealer to all exposed portions of the fins, stand-off and nose cone. Allow sealer to dry COMPLETELY, then sand lightly. Repeat the operation a couple more times to thoroughly smooth and seal the balsa.

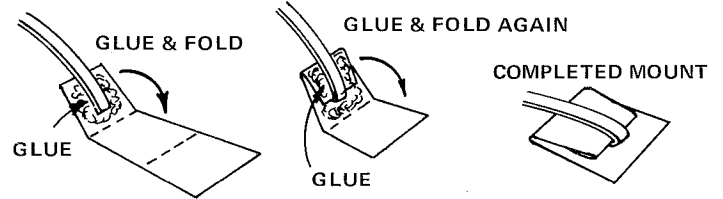

□ **23** Cut the shock cord mount from the printed sheet (part T). Crease by folding on dotted lines. Spread white glue on sec. 1 and lay the end of the shock cord (part U) in the glue. Fold over and apply glue to the back of sec. 1 and the exposed part of sec. 2. Lay the shock cord as shown and fold again. Hold unit tightly together until glue sets.

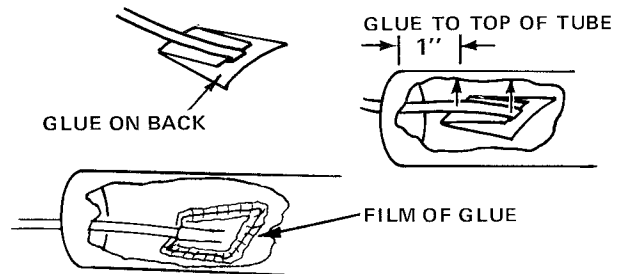

□ **24** Form the mount into a slight curve as shown. Apply glue to the back of mount and insert in top of body tube. Press in place 1" below top of tube. Hold in place till glue dries. Smear a thin film of glue over all edges of mount.

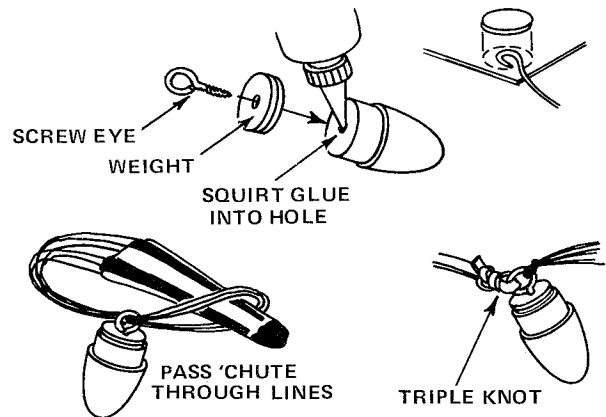

□ **25** Thread the screw eye (part Q) into the base of the nose cone, then remove. Push the shank of the screw eye through the hole in the weight (part R). Squirt white glue into the hole in the nose cone and replace screw eye (with weight). Assemble the parachute according to directions printed on the chute material. Make sure you attach the shroud lines correctly and rub the tape discs down firmly. Thread the shroud lines through the screw eye. Fold the chute, pass through the lines and pull tight. Set the knot with a drop of white glue. Tie the free end of the shock cord to the screw eye using a triple knot. Push folded chute, lines and cord into body. Socket nose cone into place, and you are ready to paint.

**ESTES INDUSTRIES**

**T.I.E. FIGHTER  
PATTERN SHEET**

**PN 84065**

 **LAUNCH LUG  
LOCATION**

**MARKING GUIDE**

 **FIN LOCATION**

 **CENTER  
BEHIND  
ENGINE  
HOOK**

 **FIN LOCATION**

-----  
**FOLD  
AROUND & TAPE**