

EAGER BEAVER



 **CANAROC** 

FLYING SPACE MODEL KIT
TROUSSE MODELE SPATIAL VOLANT
ENGINES NOT INCLUDED - ENGINES NON INCLUS

SKILL LEVEL NIVEAU DE COMPETENCE

1	2	3	4	5
BEGINNER	INTERMEDIATE	ADVANCED	EXPERT	
COMMENCANT	INTERMEDIAIRE	AVANCEE	SPECIALISTE	

RECOMMENDED ENGINES
ENGINES RECOMANDES

B2-2 B2-4 C6-4 D12-7
B4-2 B4-4 C6-5
B6-2 B6-4

SPECS

LENGTH 40 cm (15.5") DIAMETER 4.2 cm (1.65")
LONGEUR DIAMETRE

MANUFACTURED IN CANADA BY
FABRIQUE AU CANADA PAR

CANAROC INDUSTRIES LTD.
BOX 3275, EDMONTON, ALBERTA T5L 4J1

#MK-16

EAGER BEAVER

ASSEMBLY INSTRUCTIONS

READ THESE INSTRUCTIONS CAREFULLY
BEFORE YOU START BUILDING

Additional materials and tools
required for construction:

- modelling knife or
single edge razor blade
- white glue
- fine sandpaper
- butyrate dope
- cornstarch or talc
- sanding block
- paint
- scissors
- ruler

Additional items required to
fly the Eager Beaver are:

- Heat Wadding
- Trans-A-Pad Launcher
- Countdown Controller
- Canaroc Engines and igniters
- Masking Tape

PARTS LIST

- | | |
|-----------------------------------|-----------------------------------|
| A) 1 - PT-400 Body Tube (20.3 cm) | H) 2 - Engine Retainers |
| B) 1 - ET-200 Engine Tube | I) 1 - Parachute Kit (30 cm) |
| C) 1 - ET-100 Engine Tube | J) 1 - Launch Lug |
| D) 1 - CT-400 Coupler Tube | K) 1 - Balsa Sheet |
| E) 1 - BN-400A Nose Cone | L) 1 - Decal Sheet
(not shown) |
| F) 2 - Centering Disks | |
| G) 4 - Centering Rings | |

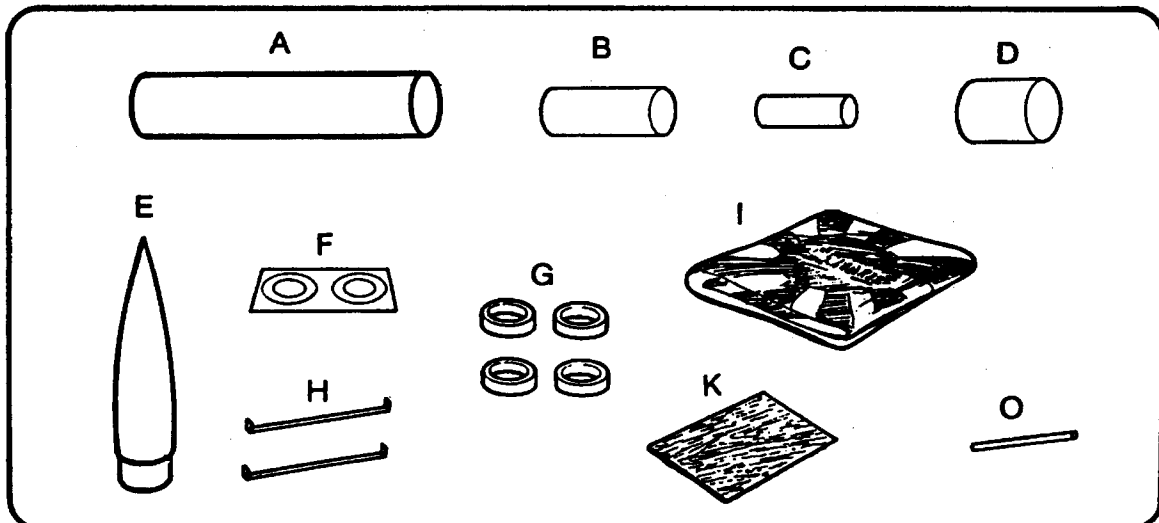

CONSTRUCT THE ENGINE MOUNT

A Cut a slit in the large diameter engine tube (ET-200) 7mm from one end (Fig. 1).

B Poke one end of the engine retainer into the slit. Put a double wrap of masking tape around the middle of the engine tube to hold the retainer in place (Fig.2).

C Smear glue around the inside of the upper end of the engine tube, and slide one of the centering rings into place, sitting against the bent end of the retainer. This will act as a "fail-safe" engine block (Fig. 3).

D Glue a centering disk to one end of the coupler tube (Fig. 4).
Cut a 5mm x 5mm notch from the remaining disk (Fig. 5).

E Slide the engine tube into the centering disk on the coupler tube, then slide the notched centering disk on the end of the engine tube and glue it into position on the coupler tube (Fig. 6). Center the coupler on the engine tube (leave the same amount of engine tube sticking out from either end). Apply a thick coat of glue to the point between the centering disk and engine tube at both ends (Fig. 7).

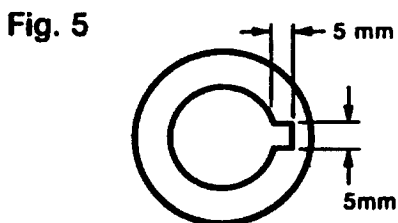
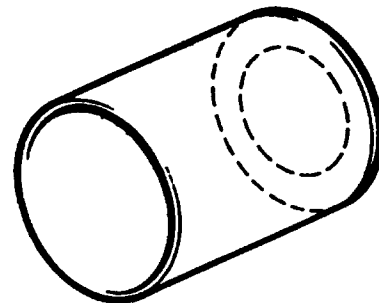
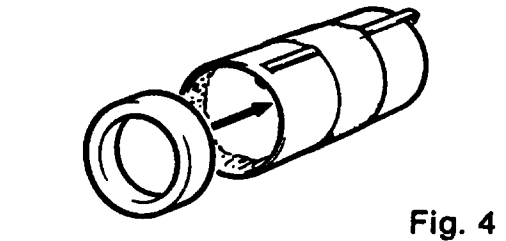
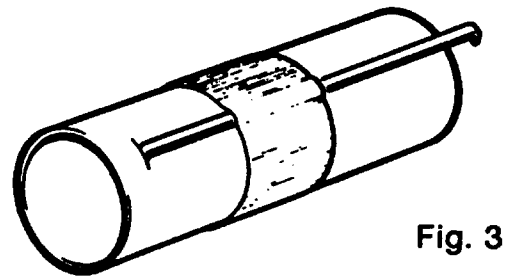
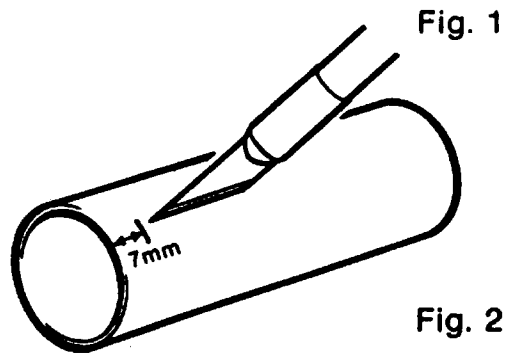

Fig. 6

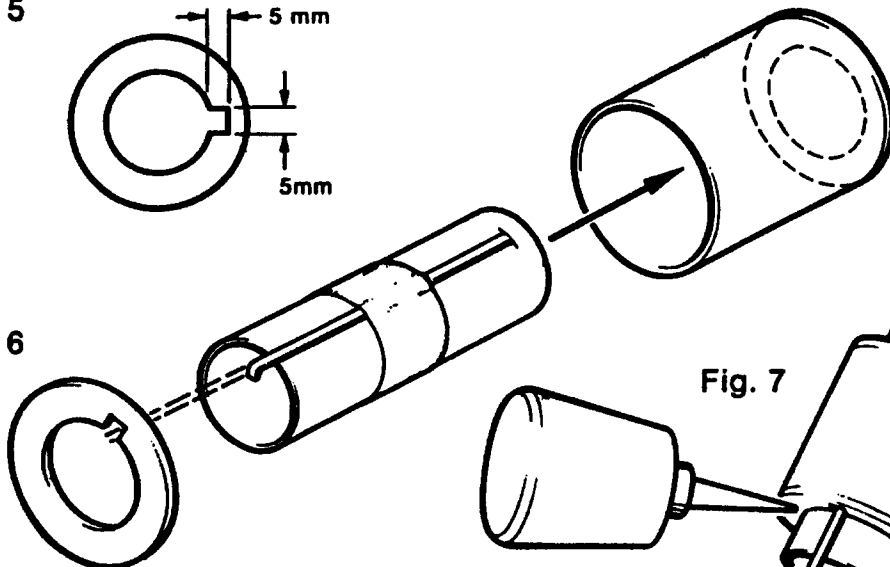

Fig. 7

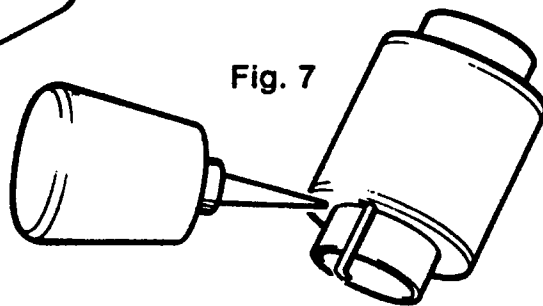

Fig. 8

CONSTRUCT THE ENGINE ADAPTER (for 18mm engines)

A Cut a slit 7mm from the end of the small engine tube (ET-100). Push the end of an engine retainer into the slit.

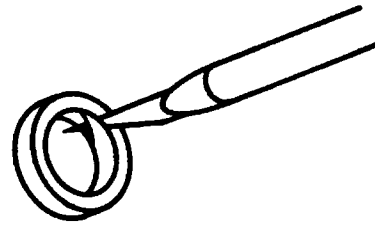

Fig. 9

B Test fit a centering ring to slide onto the tube, and over the engine retainer. If it will not slide on easily, then peel a layer of paper from the inside of the ring (Fig. 8). Smear glue around the middle of the tube on the outside, and slide the centering ring over the retainer and onto the glue (Fig. 9).

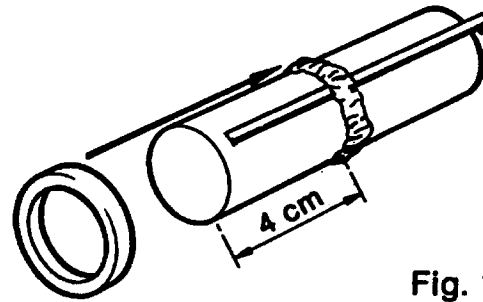

Fig. 10

C Glue a centering ring onto the front of the tube so that it is flush with the end (Fig. 10).

D Put a double wrap of masking tape around the engine tube between the two centering rings. This will help keep the retainer from being pushed forward.

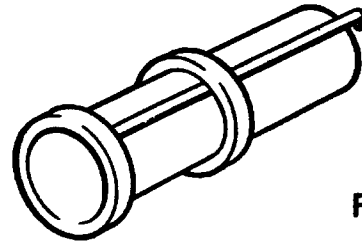

Fig. 11

E Cut a 5mm wide section from the last centering ring (Fig. 11). Smear glue around the outside of the tube at the rear, and slide the centering ring into place. Position it to be flush with the end of the tube.

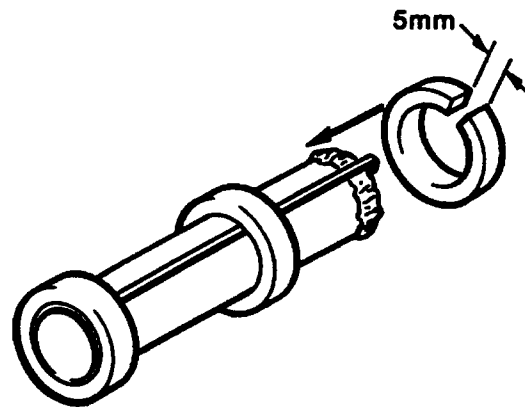

Fig. 12

NOTE: When the adapter is inserted into the engine mount to fly with 18mm diameter engines (A, B,C,) the last centering ring will stick out of the tube. This is correct, as the ring's only function is to sit against the engine mount's retainer and prevent the adapter from moving.

GLUE IN THE ENGINE MOUNT

A Smear a wide band of glue around the inside rear of the main body tube, 2 cm up inside.

B Slide the engine mount into the main tube until the coupler tube is 15 mm up inside the main tube (Fig. 12).

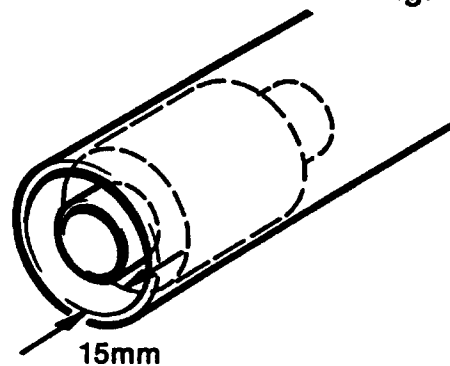

CONSTRUCT THE FINS

Fig. 13

- A Cut out the fin pattern from the pattern sheet.
- B Trace the pattern onto the balsa fin sheet. Make sure that the balsa grain direction is as shown on the pattern.
- C Carefully cut out each fin from the balsa using a modelling knife or single edge razor blade. **DO NOT ATTEMPT TO CUT THE Balsa IN A SINGLE STROKE.** When cutting balsa, run the blade lightly along the line to be cut barely applying pressure on the first stroke. On each stroke afterward, apply more force on the blade. After three or four strokes, the balsa will have a smooth clean cut. Attempting to apply too much force and making the cut in one stroke will usually tear the balsa, giving the fin an unsightly appearance.

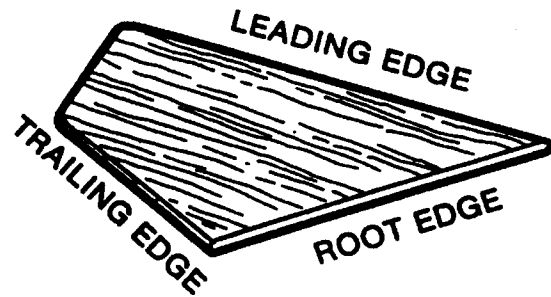
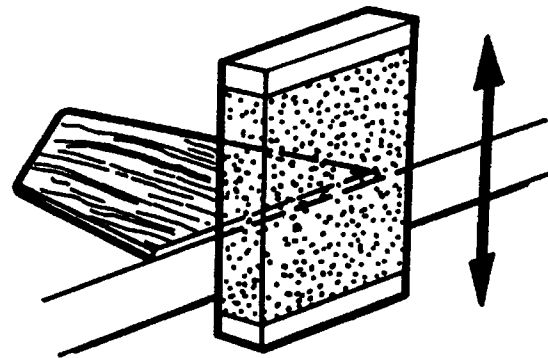
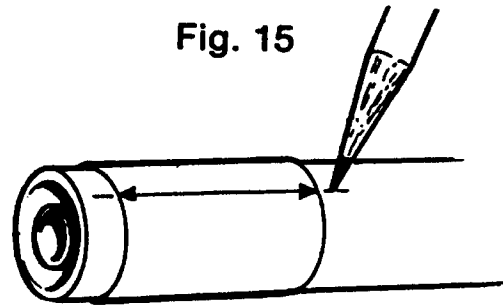

Fig. 14



- D To improve the appearance of the fins, round the leading edge and trailing edge of the fins (as shown in Fig. 13) by gently sanding with fine sandpaper or an emery board. Leave the fin tip flat, and squared off.

Fig. 15



- E The root edge of the fin, the edge that is attached to the body tube, must be perfectly flat if it is to have a strong joint when glued. Set a fin on the edge of a table, then wrap fine sandpaper around a block of wood. Hold the sanding block at right angles (90°) to the fin and sand the fin root in an up and down motion — very lightly (Fig. 14). Do this until the root edge is completely flat. Test to see if it sits flat by placing the root edge on a flat surface (such as a table top). Repeat for the other fins.

Fig. 16

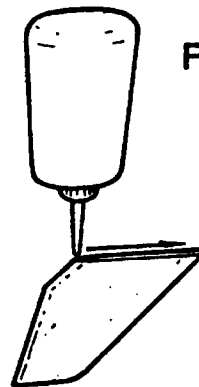
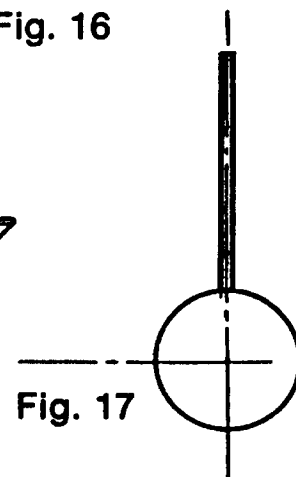

Fig. 17



MOUNTING THE FINS

- A Cut out the Fin Placement Guide from the pattern sheet.
- B Wrap the Guide around the rear of the body tube (the end with the engine mount), and tape the ends of the Guide together.

- C Place a mark on the body tube where each fin position is shown by an arrow on the Guide. These marks will show you where to align the fins when glueing them to the tube (Fig. 15).

D Place a line of glue along the root edge of a fin (Fig. 16). Place the fin on the rear of the tube along the alignment marks. Set aside until the glue has set. Be sure that the fin is sitting at 90° to the tube when viewed from the end (Fig. 17).

E Repeat the procedure to glue on the other fins. All fins should be evenly spaced around the tube when completed.

F Once all the fins have dried, lay a thin line of glue along each fin joint to form a "fillet" and strengthen the fin. Smooth out the line of glue neatly with the tip of your finger.

FINISHING THE Balsa PARTS

Raw balsa is unsightly, coarse and grainy, if painted before the grain is "filled" and the surface is "sealed". Model rockets look professional if the time is taken to finish the balsa. The Guide to Space Modelling contains tips on finishing and may be consulted for assistance.

A The most common method of finishing balsa uses butyrate dope, available from most hobby outlets. To assist in filling the balsa grain, cornstarch, talc, or baby powder may be rubbed into the balsa and worked into the grain. Brush on a thick coat of dope, be sure to do both sides of each fin at the same time in order to avoid warping.

B After the dope dries completely, lightly sand the balsa surfaces with fine sandpaper. The sanding operation removes the excess thickness of dope and speeds up the process of filling the grain.

C After repeating the doping/sanding operation three or four times, the balsa grain should be filled and the surfaces smooth. The last sanding operation should be done with extra fine sandpaper.

SHOCK CORD MOUNT

A Cut the Shock Cord Mount from the pattern sheet.

B Construct the Mount as shown in Fig. 18. Fold the panels so that the shock cord folds with it.

Fig. 18

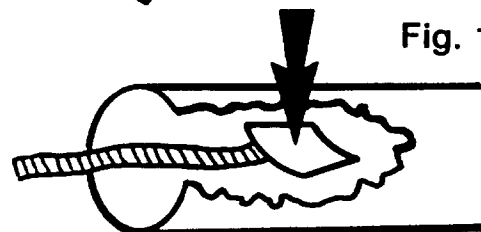
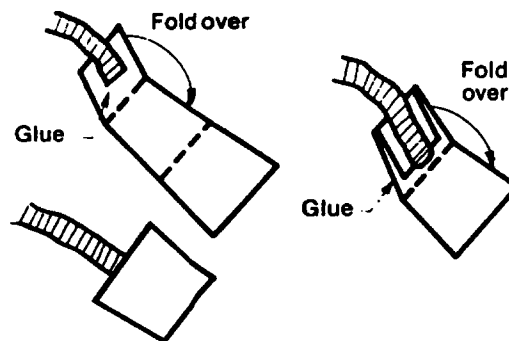

Fig. 19

C Spread glue on the folded side of the Mount and insert it into the front of the main body tube at least 5 cm inside. Press it firmly against the wall of the tube (Fig. 19).

LAUNCH LUG

A Glue the launch lug alongside one of the fin joints.

ATTACHING THE NOSE CONE

A Pierce a hole with the modelling knife for shock cord attachment

B Tie the free end of the shock cord to the eyelet and make a solid knot.

C Trim off and sand smooth any flash along the seam of the nose cone.

PARACHUTE

A Construct the parachute using the instructions on the parachute pattern.

B Tie the knotted end of the parachute shroud lines to the eyelet in the base of the nose cone.

PAINTING

- A Whether brushing or spraying, a base coat of white should always be applied. Paint should always be applied in thin coats to speed drying and prevent unsightly "sags".
- B Final colors may be applied over the base coat when it has dried. Where necessary, masking tape may be used to separate colors. If spraying, cover the remaining areas with plastic wrap or paper.
- C When spray painting, hold the can about 20 cm to 30 cm from the model, and spray in even strokes. Do not apply the paint too thickly or it will "run" and leave a "sag" in the surface. When brushing, be sure that the paint is not too thick, so that it may be properly brushed out and not leave brush streaks on the surface.
- D When the final coat is dry remove masking tape by slowly peeling it back against itself, being careful not to peel off the base coat.

DECALS

To apply decals please follow instructions on back of decal sheet.

FLYING

- A Install the engine by sliding it into the engine tube until it is locked firmly between the two ends of the engine retainer wire. If the model is to be flown with 18mm diameter engines (A, B or C,) then the adapter must be slid into the engine mount first.
- B Push a piece of recovery wadding down into the top of the tube. The wadding serves to protect the plastic parachute from melting by the hot gases of the engine's ejection charge. There should be about 3 cm thickness of wadding to create a good piston between the parachute and the engine.
- C Fold the parachute in the following manner:
 - hold the tip of the parachute with one hand and the shroud lines with the other.

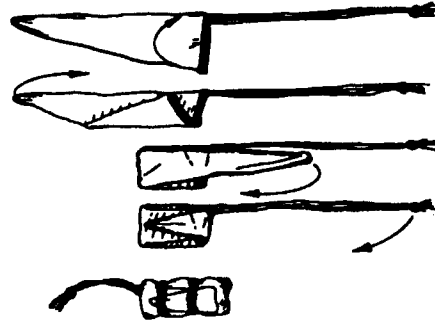

- gather together all of the free corners so that the parachute forms a triangle.
 - fold over the corners.
 - fold over the parachute into thirds.
 - wrap shroud lines around the bundle.
- D Put the parachute, shock cord, and the remaining shroud lines into the tube, then slide on the nose cone.
 - E Install an igniter into the engine according to the instructions.
 - F Slide the rocket onto the launch rod, sliding the rod through the launch lug. This will guide the rocket at the moment of launch.
 - G Attach the igniter clips to the leads of the igniter.
 - H Insert the safety key into the launch controller, give a 5 second countdown and press the button to launch the model.

CANAROC



MANUFACTURED BY
IRWIN TOY LTD.
43 Hanna Avenue
Toronto, Canada
M6K 1X6

**SHOCK CORD MOUNT
MONTAGE DU CORDON
AMORTISSEUR**

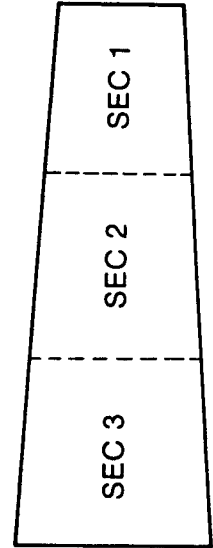

**FIN PLACEMENT GUIDE
GUIDE DE REPERAGE DES AILETTES**

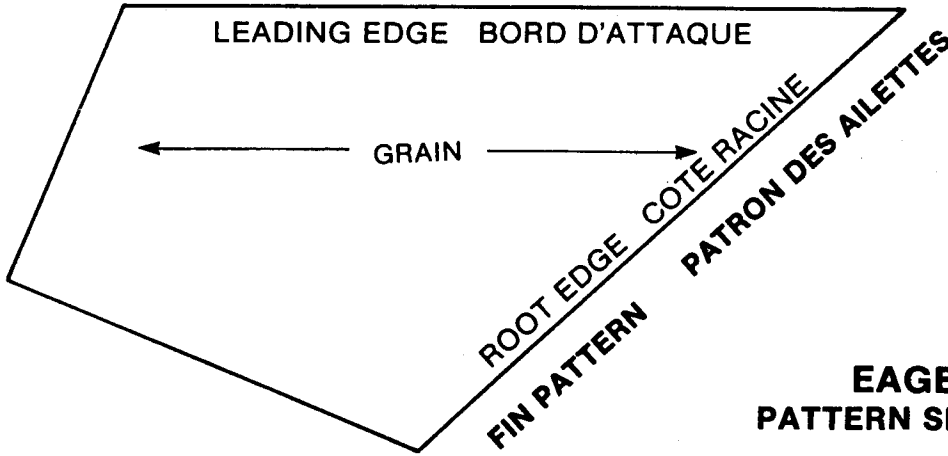
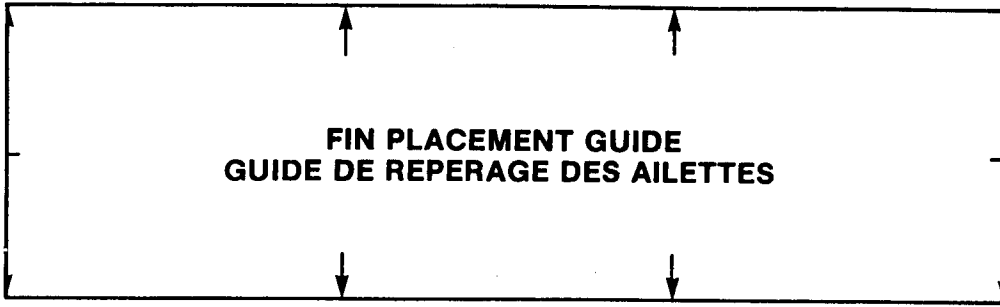

**EAGER BEAVER #54009
PATTERN SHEET FEUILLE DE MODELE**

54009004

54009004

**EAGER BEAVER #54009
PATTERN SHEET FEUILLE DE MODELE**

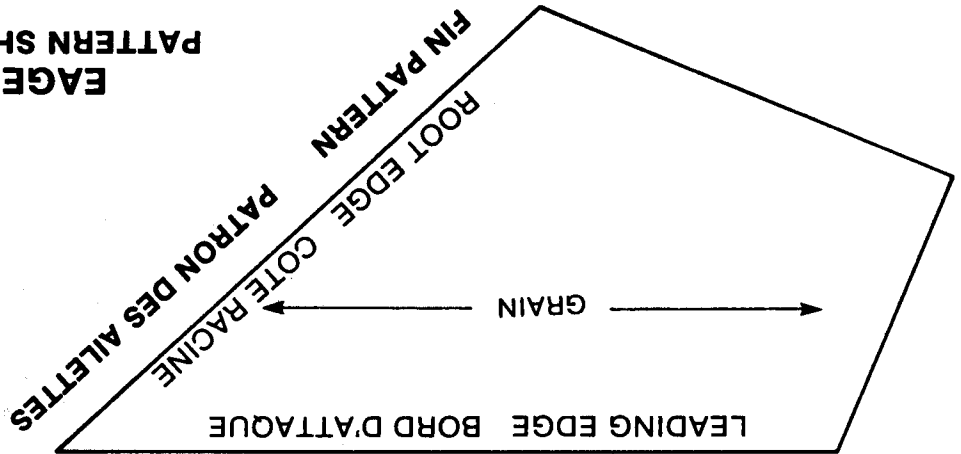
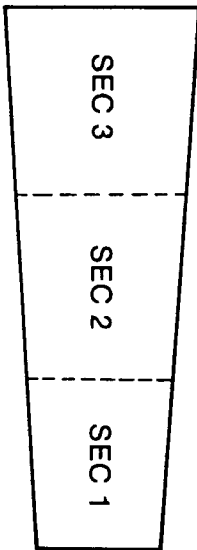

**FIN PLACEMENT GUIDE
GUIDE DE REPERAGE DES AILETTES**

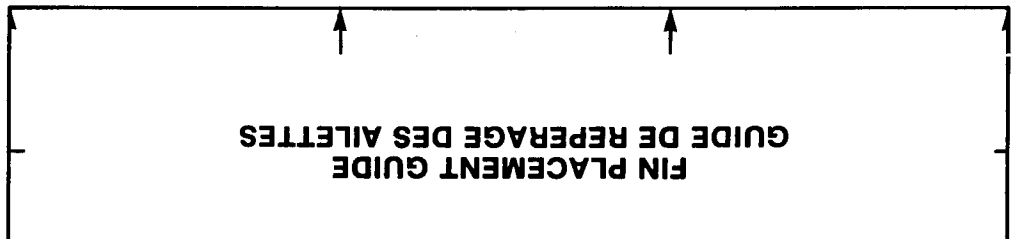

1	2	3	4	5	6	7	8
1	2	3	4	5	6	7	8
9	10	11	12	13	14	15	16
17	18	19	20	21	22	23	24
25	26	27	28	29	30	31	
JANUARY							
1	2	3	4	5	6	7	8
9	10	11	12	13	14	15	16
17	18	19	20	21	22	23	24
25	26	27	28	29	30	31	
FEBRUARY							
1	2	3	4	5	6	7	8
9	10	11	12	13	14	15	16
17	18	19	20	21	22	23	24
25	26	27	28	29	30	31	
MARCH							
1	2	3	4	5	6	7	8
9	10	11	12	13	14	15	16
17	18	19	20	21	22	23	24
25	26	27	28	29	30	31	
APRIL							
1	2	3	4	5	6	7	8
9	10	11	12	13	14	15	16
17	18	19	20	21	22	23	24
25	26	27	28	29	30		
MAY							
1	2	3	4	5	6	7	8
9	10	11	12	13	14	15	16
17	18	19	20	21	22	23	24
25	26	27	28	29	30	31	
JUNE							
1	2	3	4	5	6	7	8
9	10	11	12	13	14	15	16
17	18	19	20	21	22	23	24
25	26	27	28	29	30	31	
JULY							
1	2	3	4	5	6	7	8
9	10	11	12	13	14	15	16
17	18	19	20	21	22	23	24
25	26	27	28	29	30	31	
AUGUST							
1	2	3	4	5	6	7	8
9	10	11	12	13	14	15	16
17	18	19	20	21	22	23	24
25	26	27	28	29	30	31	
SEPTEMBER							
1	2	3	4	5	6	7	8
9	10	11	12	13	14	15	16
17	18	19	20	21	22	23	24
25	26	27	28	29	30		
OCTOBER							
1	2	3	4	5	6	7	8
9	10	11	12	13	14	15	16
17	18	19	20	21	22	23	24
25	26	27	28	29	30	31	
NOVEMBER							
1	2	3	4	5	6	7	8
9	10	11	12	13	14	15	16
17	18	19	20	21	22	23	24
25	26	27	28	29	30		
DECEMBER							
1	2	3	4	5	6	7	8
9	10	11	12	13	14	15	16
17	18	19	20	21	22	23	24
25	26	27	28	29	30	31	

AMORTISSEUR