

\$ 10.00

X - 13

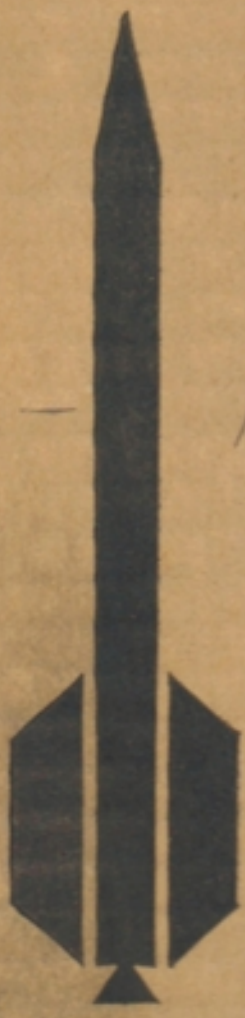

**FRAGILE**  
**HANDLE WITH CARE**

CAUTION CONTENTS IN  
AEROSOL CANS UNDER PRESSURE.  
READ PRECAUTIONS ON CAN.

MADE IN U.S.A. U.S. AND FOREIGN PATENTS PENDING

VASHON INDUSTRIES, INC.  
BOX 309, VASHON, WASHINGTON 98070



The

# X-13

## ROCKET PLANE

**FOLLOW THESE DIRECTIONS VERY CAREFULLY!** Read through them completely first, so you will know the general procedure. Then assemble your rocket plane step by step.

### PLANE ASSEMBLY

- Step 1 Cut out and glue the wing sections together. Use Elmers White Glue or equivalent, for all balsa-to-balsa wood joints.
- Step 2 Measure, cut and assemble the balsa body stick with white glue. Cut a 3 inch length of rail, trim both ends, and cement to the body as shown. Use the contact adhesive provided. Apply adhesive to both pieces, allow to dry until very tacky, then press together firmly.
- Step 3 Glue the rudder to the stabilizer using assembly fixture as shown. After the wing and tail assemblies are completely dry sand all surfaces and apply a thin fillet of cement over all joints to provide added strength.
- Step 4 Assemble the wing assembly and tail assembly to the body with white glue. Make sure the assembly is square, then set aside to dry.
- Step 5 To apply Super Monokote: Set an iron just below the melting point of the Monokote (usually "cotton-wool"). Cut a piece of Monokote to match the surface to be covered, leaving a 1/4 inch margin on all sides. Peel Monokote from its clear backing and lay on surface, adhesive side down. (If you forget which side is adhesive, the hot iron will stick only to the adhesive side.) Touch edges with iron to attach, then lightly press Monokote onto surface and around edges. Trim with scissors or knife. Repeat this process on the opposite surface. (If bubbles form, pierce with a pin and re-press.) Apply decals to complete the plane.
- Step 6 The approximate balance point of the X-13 is shown in Step 4. Add weight (wire brads) to nose or tail until the model balances at this point. Test for balance by gently throwing the plane straight out at shoulder level. If the plane noses upward into a stall, add weight to the nose; if it dives, remove weight. Proper balance is essential for a good flight.

ASSEMBLY INSTRUCTIONS No. 5071-1

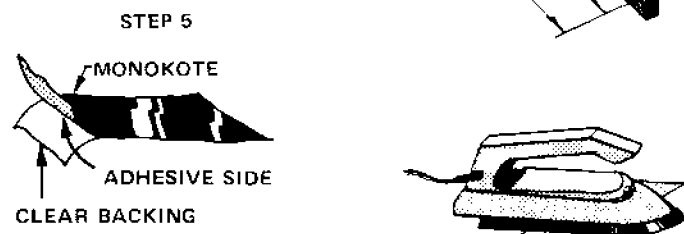
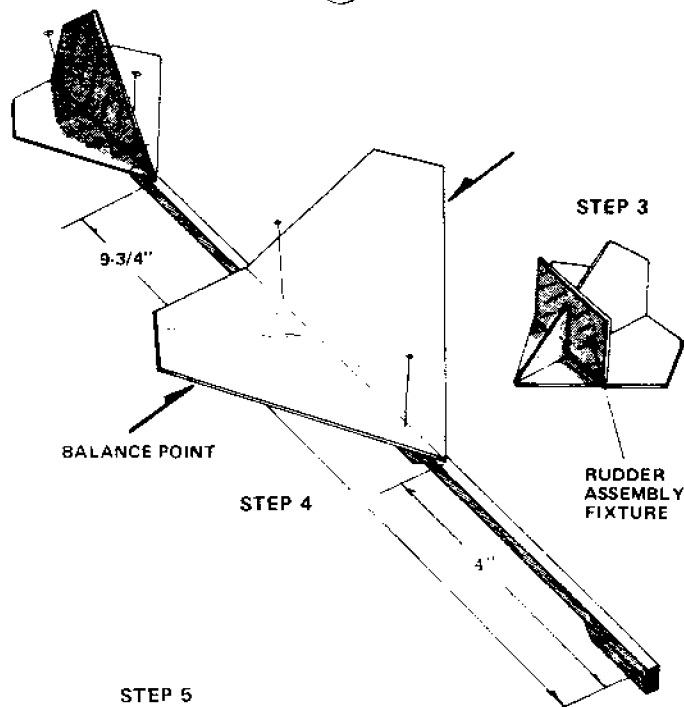
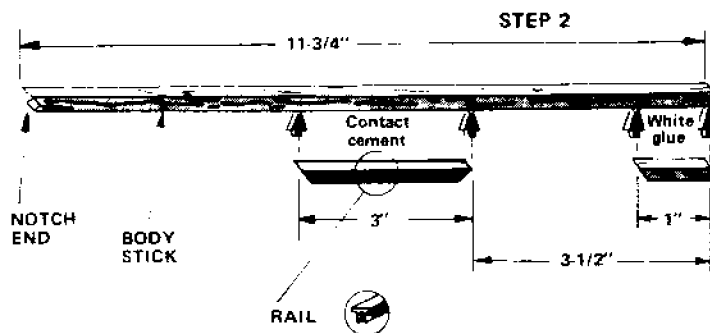
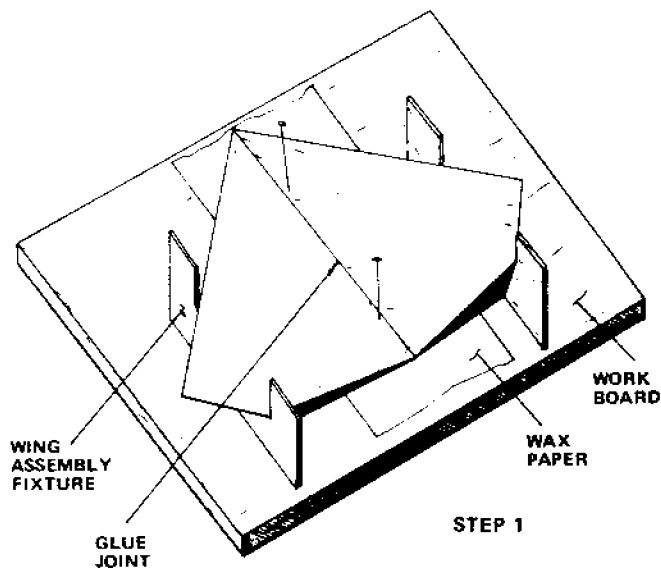

## ROCKET ASSEMBLY

- Step 1** Place engine nozzle down in the center of the alignment guide (Figure 1). Locate rubber fill valve in the position shown. Reflection on the wall of the tube shows location and width of the glue joint areas. Scrape these areas thoroughly as shown in Figure 2. Scrape a 4 inch long area for the full length launch guide tube.
- Step 2** Cut three 3-inch pieces of rail and one 3 inch length of plastic tube. Slope the front ends of the fin rail, and chamfer the inside of the back ends (so the fins will slide in easily). Apply contact adhesive to scraped areas on engine and to rails and tubes. Allow to dry until very tacky, then press each item firmly in place.
- Step 3** Thread a piece of elastic shock cord through the 3 inch catapult tube as shown in Figure 6. Tie a loop and a large knot as illustrated. The upper knot must be large enough not to slip through the hole when the cord is stretched.
- Step 4** Remove the black vinyl tape from it's backing and tape the adapter tube to the fibre parachute tube. Cut an inch of tube for a stop, and cement to the parachute tube in the position shown in Figure 6.

If you are converting a Valkyrie-2 rocket (8.5 inch long engine) into a rocket plane, use a 4 inch section of tube for a stop in the position shown below.

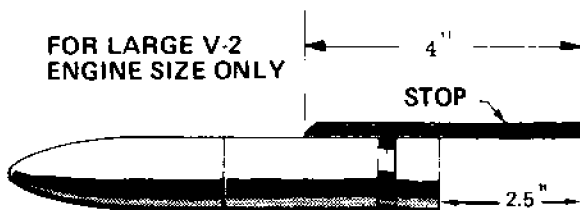

- Step 5** Cut a length of thread and tie to nose cone as shown in Figure 6. Tie a loop in the opposite end and thread through the parachute tube.
- Step 6** Cut the parachute material and attach parachute shrouds as shown in Figure 3. Attach a length of shock cord to the snap swivel and to the shrouds as shown in Figure 4.
- Step 7** Attach the snap swivel to the nose cone thread and to the separator. Screw separator onto engine with coupling and two paper timer discs.
- Step 8** Cut out two rocket fins, sand, apply Monokote, and slide into fin rails from one end. If your kit has a styrofoam nose cone, lightly sand to a dull finish, apply Testor's contour putty (or paste wood filler) to nicks, and paint with Pactra'Namel (not spray type), polyurethane, or epoxy enamel. Styrofoam requires special paint: test your paint on a styrofoam drinking cup first. Apply decals to complete the rocket.

## ALIGNMENT GUIDE

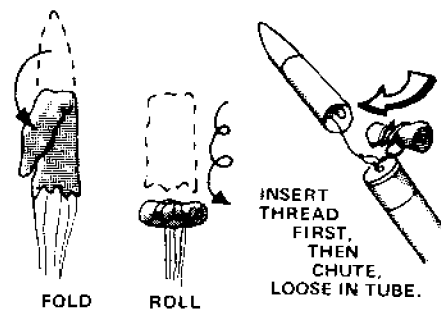
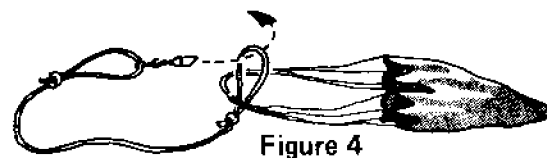
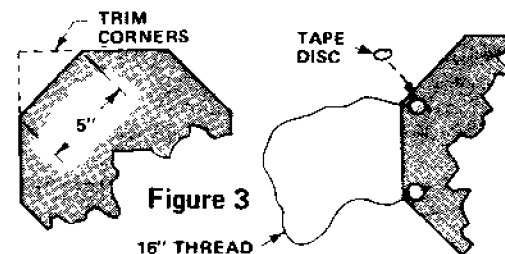
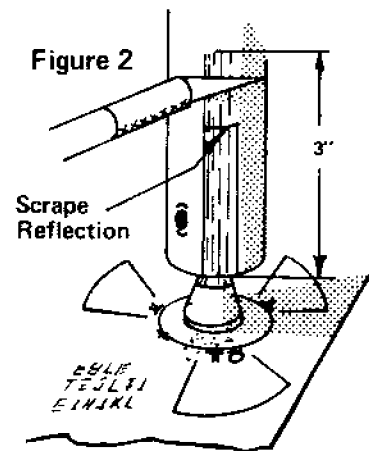
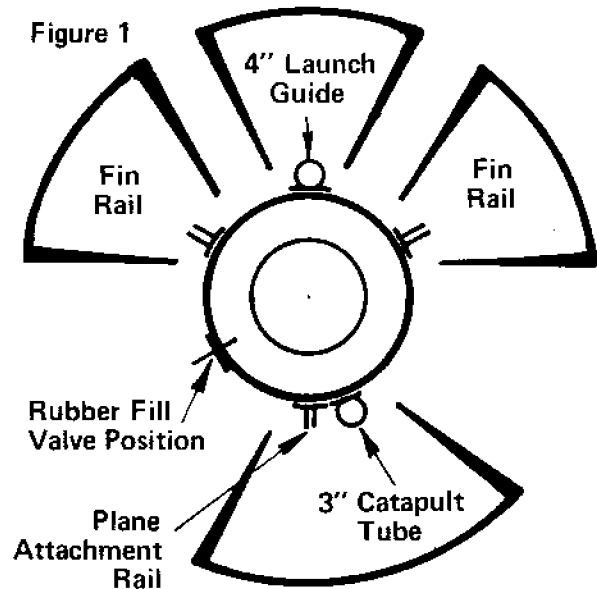
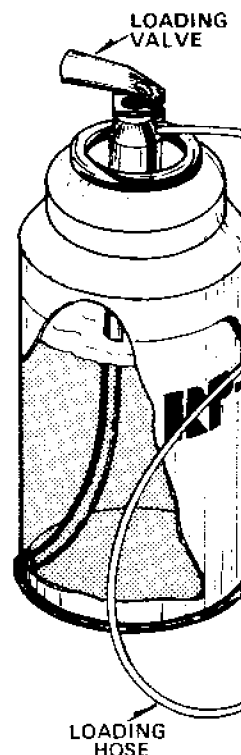

Figure 5



FIB  
PAR

ALUMINIUM

## PRE-FLIGHT CHECK OUT

- Step 1 Oil and insert the nozzle plug and the safety pin. Smooth off end of pin so it slides freely.
- Step 2 Fold and insert the parachute as shown in Figure 5. The thread goes in first. Parachute should be loose and free to fall out of tube.
- Step 3 Hold the parachute tube on the separator with the stop aligned with the plane rail. While holding the tube in place, press the loading valve briefly (1/2 second) to pressurize the engine. Nose cone should latch in place.

**TROUBLE?** Parachute tube must be held squarely to latch in place, and will not latch after engine is pressurized. Release plug to vent engine, and try again. A leak at the timer discs may also prevent latching. Screw separator on more firmly.

- Step 4 Slide the plane onto its rail (rails must fully interlock) and up against the stop. Place the loop of the catapult elastic cord onto the tail notch. The plane should be held in place by the cord against the stop.

If the nose cone and parachute tube are bent out of alignment, lengthen the cord to reduce the tension.

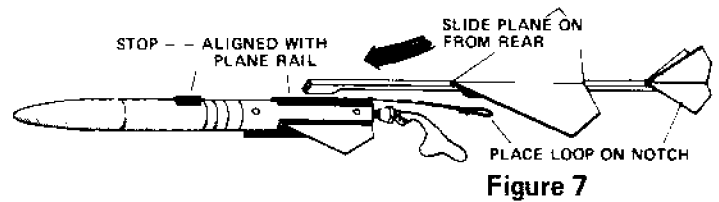

Figure 7

- Step 5 Hold the rocket plane firmly by the engine so that the plane will be free to slide forward, and pull the safety pin. After a brief interval, the parachute tube should release, and the plane should catapult free. Smooth off ends of rails so they slide freely, and adjust catapult cord as required to achieve proper plane release.

Figure 8  
Pre-Flight  
Test

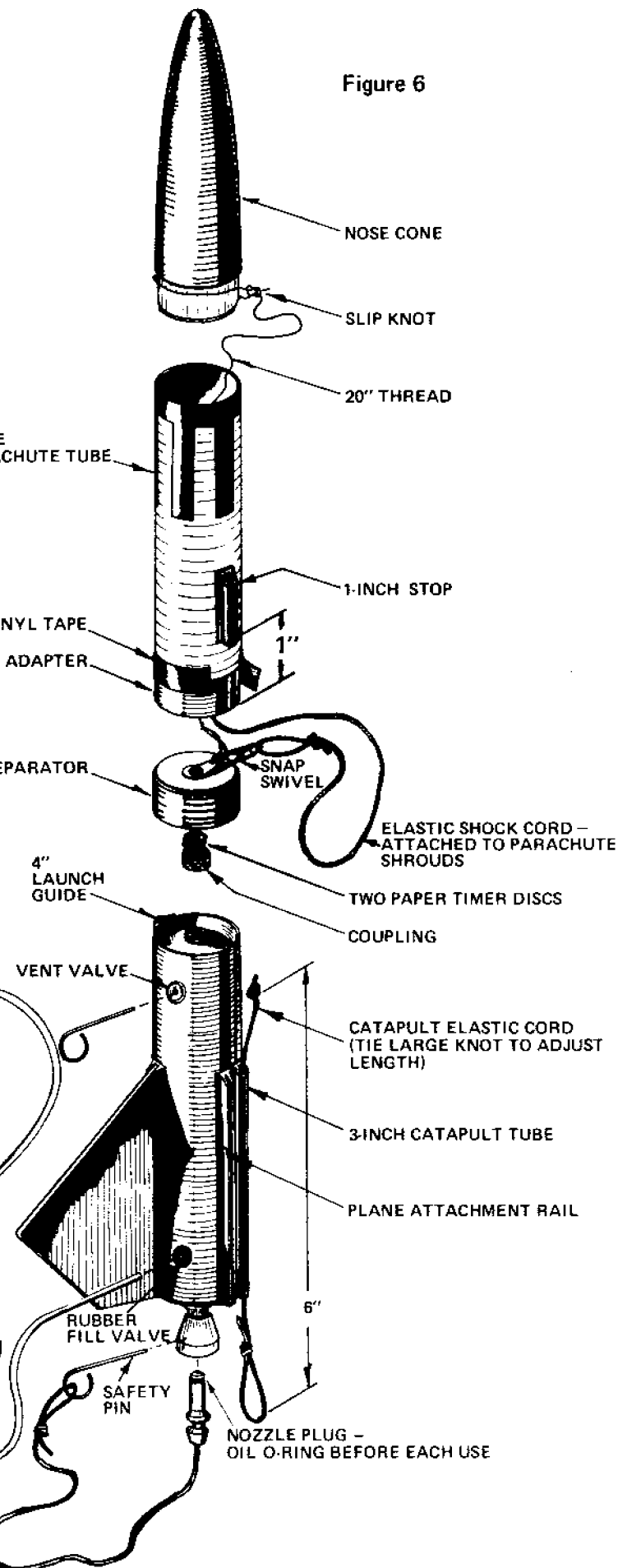
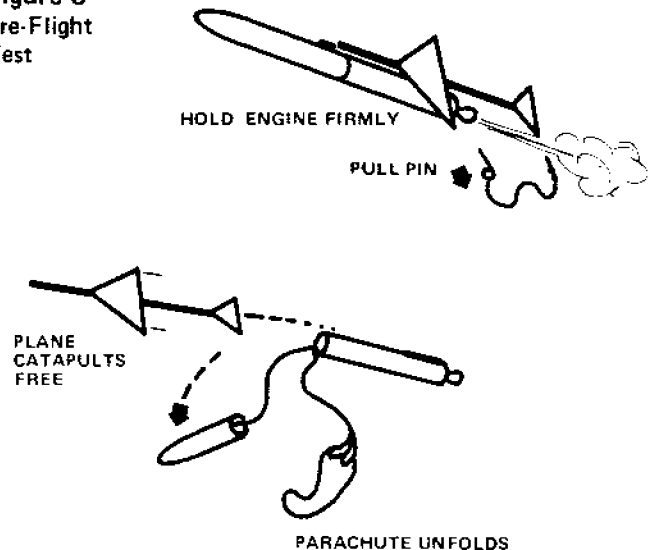

Figure 6

# LAUNCH PROCEDURE

As a responsible rocketeer, you should take care to observe the following precautions.

## General Precautions

1. Use only RP-100 propellant.
2. Always have the safety pin installed and the nozzle extension firmly pushed in place before loading the rocket.
3. Do not point the nose or nozzle of a loaded rocket at anyone.
4. Never carry or store a loaded rocket.
5. Never fly a rocket without adequate fins.
6. Always use a launcher and launch the rocket vertically.
7. Always have an adult present when you load or launch your Rocket.

## COUNTDOWN

- T-8 Set up launcher in middle of field. Allow 100 yards in all directions for recovery. Make sure launcher is stable.
- T-7 Oil and install the firing assembly plug and safety pin and slide the engine onto the launcher.
- T-6 Fold and pack the parachute into the parachute tube.
- T-5 While holding the parachute tube in place and in line insert the loading hose and pressurize the engine. Verify that the tube is latched in place. If tube is latched the engine is ready to load.
- T-4 **Fueling:** Insert a safety pin in the vent valve at the top of the engine, and while holding the loading valve lever down, vent SLIGHTLY by pushing down on the vent valve pin. Vent only enough to allow propellant to flow into the engine. Repeat venting until engine is full (white mist sprays out of vent valve). Carefully remove hose.
- NOTE: If engine grows cold you are venting too fast. VENT SLOWLY.
- T-3 Slide plane onto its rail and attach shock cord.
- T-2 Alert everyone within range that you are ready to launch.
- T-1 Make sure that airspace above launching area is clear and no airplanes are near.
- ZERO: BLAST OFF! While bracing the nozzle with your finger, pull the safety pin quickly from the nozzle extension to launch the rocket plane.

*NOTE: The user must exercise care in the use of Vashon Industries products and strictly comply with the precautions stated above and the instructions provided. The user assumes all risk of use or handling. Vashon Industries makes no warranty of any kind, express or implied, and assumes no liability beyond the replacement of parts which, in the judgment of Vashon Industries, are defective.*

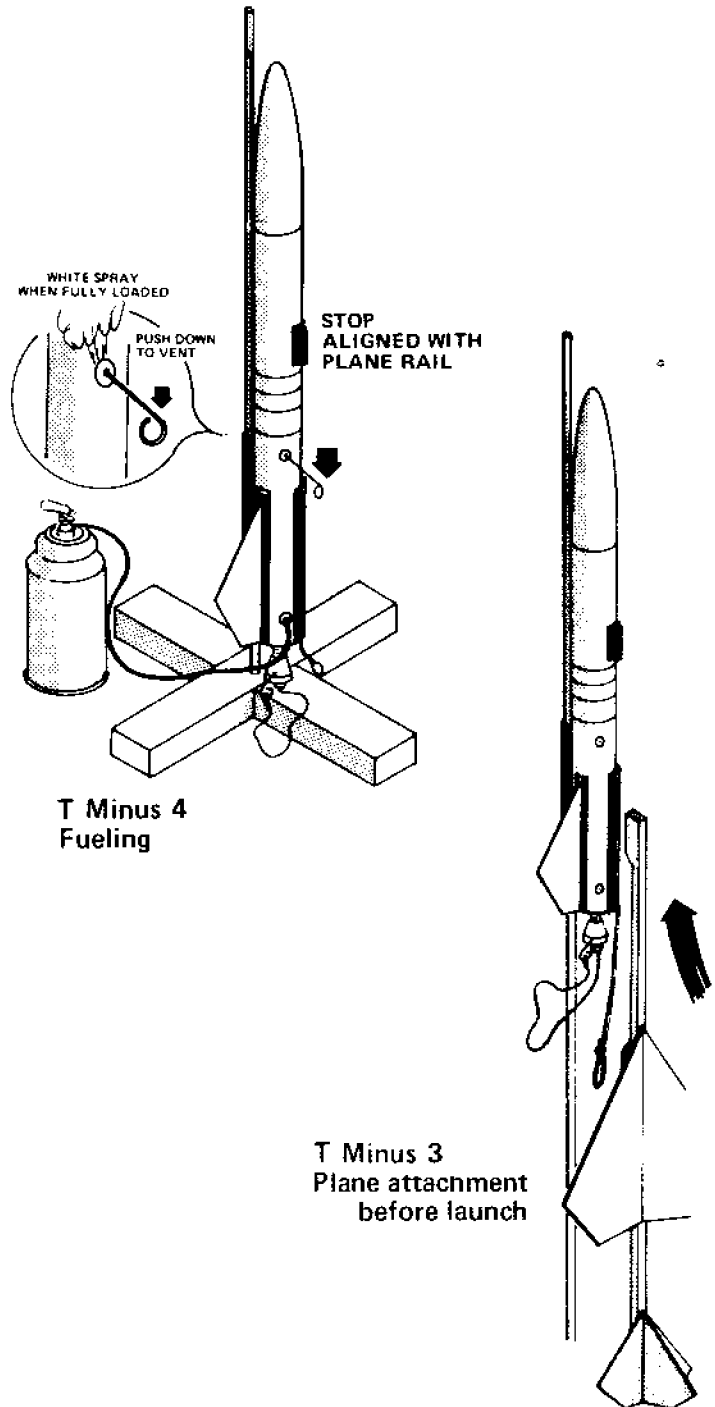

## FLIGHT TIPS

1. For best launch performance, keep propellant warm.
2. Plane should separate on the way up, not on the way down. Adjust timer discs (pierce one with a pin if necessary) to cause separation before peak altitude.
3. If your plane turns sharply into a vertical dive, yet is balanced, warped wings may be the cause. Use a hot iron to heat the wing surfaces while twisting to straighten wings. Or, add a small weight to the wing that lifts in the turn, to counteract the turn. The body stick may also be warped downward at the tail. Bend the tail slightly upwards. Moistening the body stick may help.



# X-13 ROCKET PLANE KIT

## PARTS LIST

5001	V-1 Engine	\$4.95
5002	Separator	1.95
5115	Parachute Kit	1.50
5120	Parachute Compartment Kit	1.50
5120	Fin Rail and Launch Guide	.50
5117	Parachute Kit	1.50
5007	Parachute, shroud thread, shock cord, tape meas., snap & eyelet	1.50
5055-19	Timing Valve and Hose	1.75
5055	Small Parts Kit	1.00
5004-3	Diode	1.15
5005	Igniter Wire	1.00

## ACCESSORIES

<u>Launch Equipment</u>		
5007	V-1 Engine	\$4.95
5008	Launch Plane	1.15
5009	X-13 Plane	1.65
<u>Load-It-Launch Equipment</u>		
5005	36" Tripod Launcher	1.25
5003	RP-100 Propellant, 15 oz.	1.05
5004	RP-100 Propellant, 7-1/2 oz.	1.25
5115	Remote Electrical Firing Unit	1.50
5007	Igniter Wire, 3' length	1.00
<u>Multi-Stage Equipment</u>		
5000	Staging Adapter Kit	1.25
5117	Multi-Stage Booster	1.25
5001	V-1 Engine (Small)	4.95
5002	Separator	1.95

### Special Features in THIS KIT:

**MANUAL FIRING ASSEMBLY**, with a single front-rear wire. You will find it handy to tie the wire to the safety pin to prevent loss of either part. (For Cape Kennedy realism, get the Remote Electrical Firing Unit to launch your rocket from a distance.)

**LARGE TWO-PIECE PARACHUTE TUBE**, which makes parachute packing easier. Tape the aluminum adapter to the fiber tube with the tape provided.

**COMPLETE PARACHUTE** - Shroud line and tape made and provided for the parachute in the kit. Vashon's is yours.

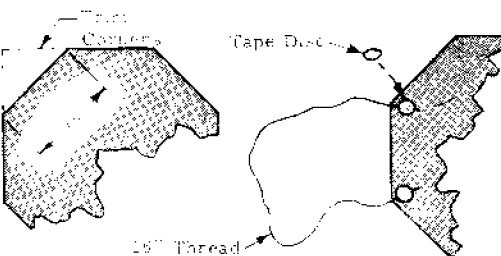

## A TYPICAL

## VASHON MODEL ROCKET

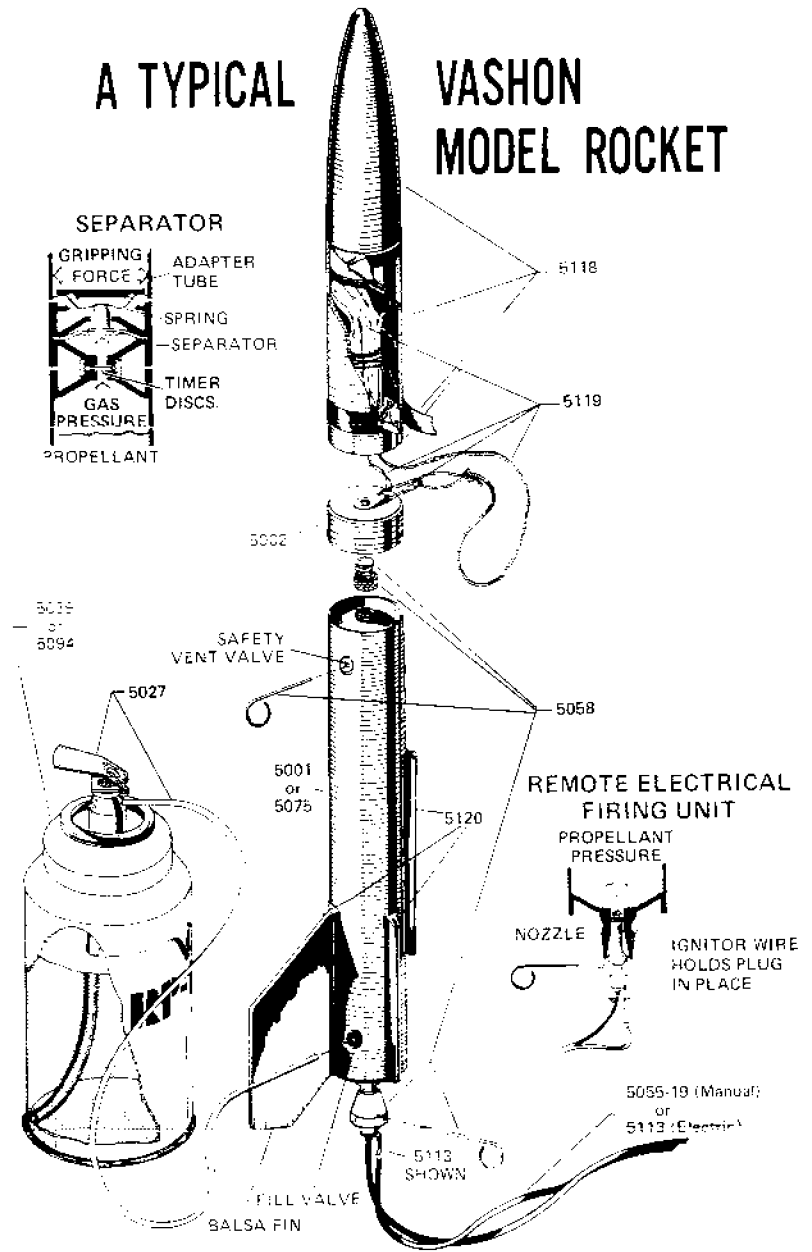

Separator requires special care. To pack it, use an appropriate alcohol lamp. Protect (Name) (NOT the spray type), or polyethylene materials. Use only paint on a styrene or polystyrene cup before using on the base disc. Nicks may be filled with Testors Clear or Putty or other paste wood fillers.

Do not use alcohol ONLY at the factory. Engines and separators are repaired to original condition and are ready, regardless of purchase date. Deteriorate parts are replaced at no cost.

See your dealer for parts and accessories. The best buy there, you may order direct from the factory. Please use part numbers when ordering and show resistance with fraud. No C.O.D.'s are accepted. Washington residents add 4.5% sales tax.

**VASHON INDUSTRIES, INC.**  
Box 309 Vashon, Washington 98070



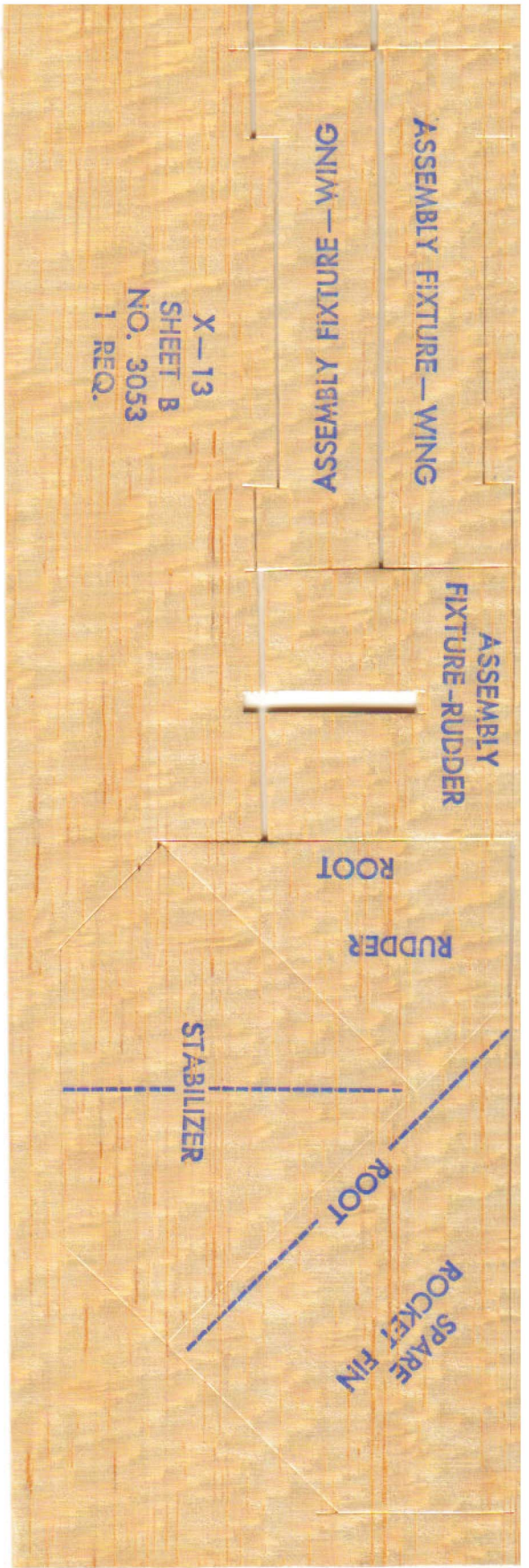
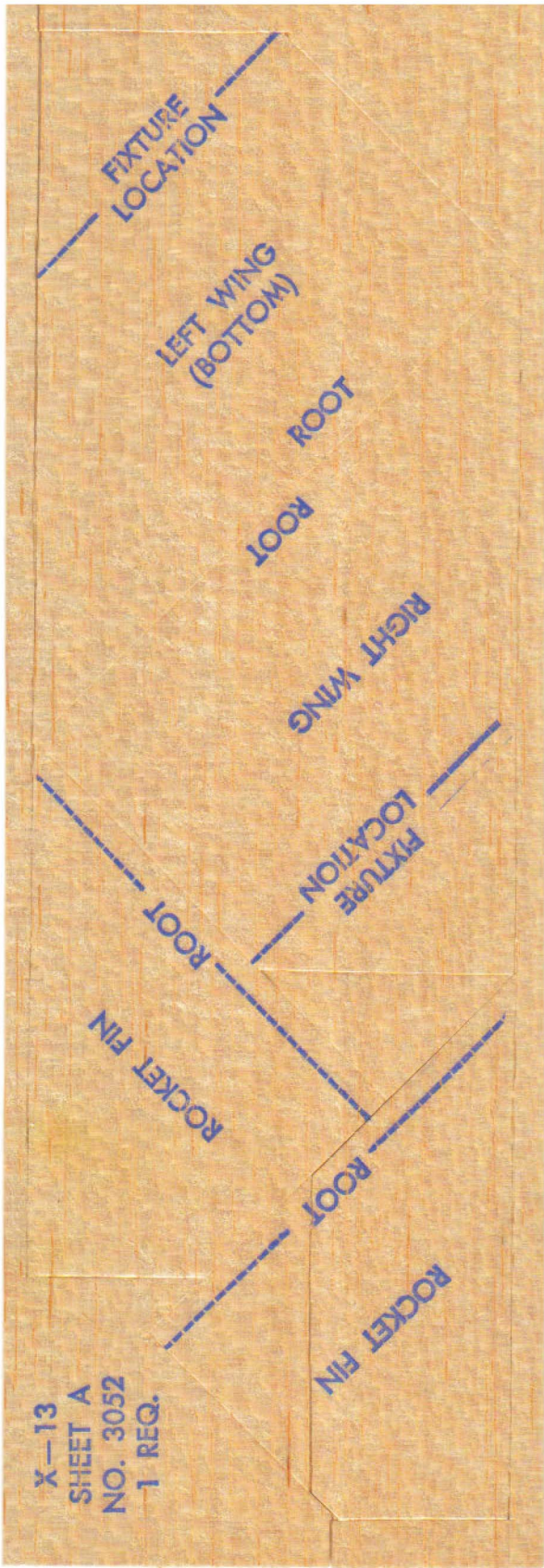

**1**  
**square**  
**inch**

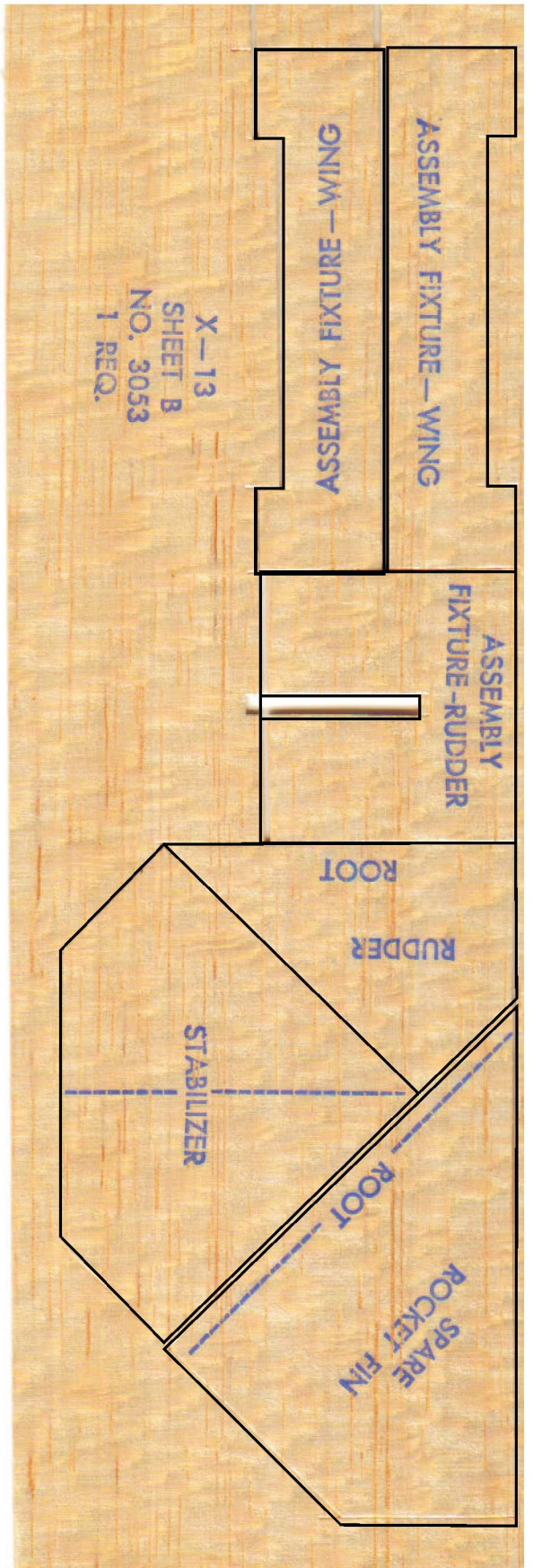
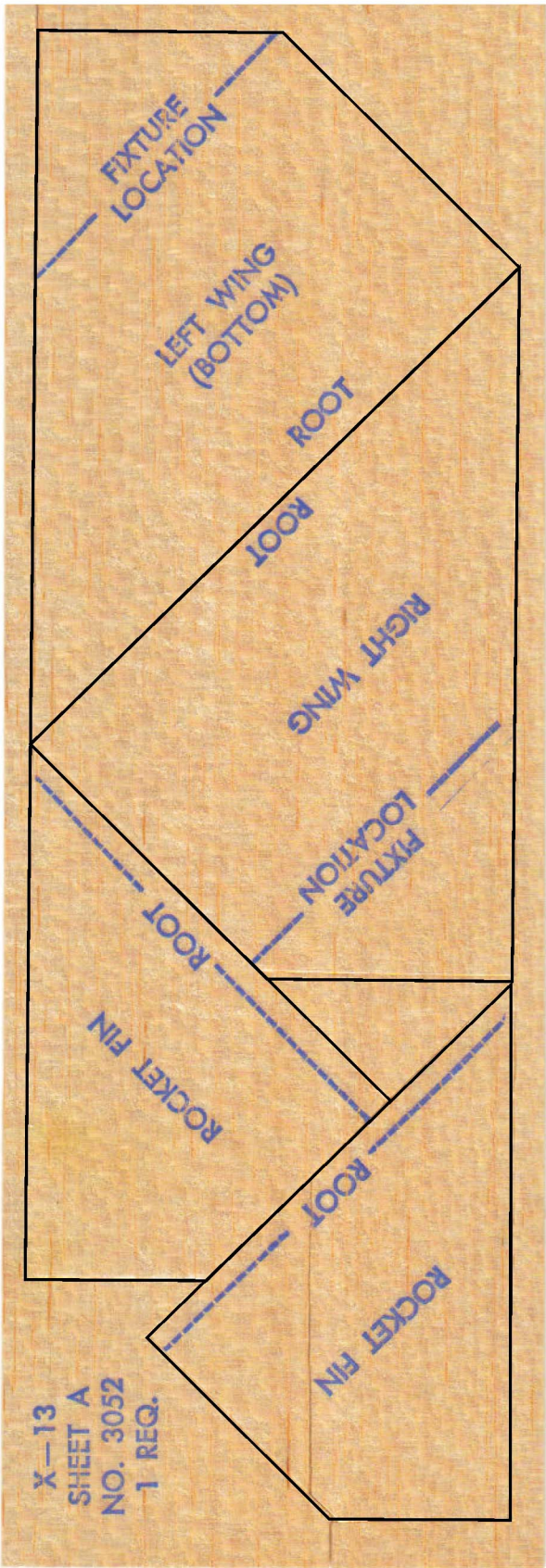

**1**  
**square**  
**inch**



USAF  
5069

ROCKET POWERED 

 ROCKET POWERED

U.S. AIR FORCE



5080-3

VASHON

X-13

X-13

VASHON

1  
square  
inch

**1  
square  
inch**

CUT HERE

CUT HERE



CUT HERE

CUT HERE

Extra-light, extra-strong  
MYLAR® PARACHUTE  
"The Echo Satellite Material"

\*DuPont Trademark

VASHON INDUSTRIES, INC.  
Box 309, Vashon, Washington 98070







**1**  
**square**  
**inch**

## Separator Service Policy

If you damage your separator for any reason, you may return it to Vashon Industries, Inc. for repair or replacement. The total charge is \$1.00 which covers the repair service and the cost of all parts needed.

Return only the damaged separator with check or money order for \$1.00. Washington residents add 5¢ for state sales tax. (NO C.O.D.)

Send to:

**Service Department**

**VASHON INDUSTRIES, INC.**  
Box 309, Vashon, Washington 98070



OVER FOR ENGINE REPAIR SERVICE

## Warranty

All parts of this product are guaranteed by Vashon Industries, Inc., against defects of manufacture if returned within 60 days from date of purchase. Any part found defective will be repaired or replaced without charge provided the defective part is returned postpaid to Vashon Industries, Inc., Customer Service Dept., Box 309, Vashon, Washington 98070.

*For fastest service, please send only the defective part.*

— CUT HERE AND MAIL TO VASHON INDUSTRIES —

### WARRANTY REGISTRATION CARD

NAME \_\_\_\_\_ AGE \_\_\_\_\_

ADDRESS \_\_\_\_\_

CITY \_\_\_\_\_

STATE \_\_\_\_\_ ZIP \_\_\_\_\_

PURCHASED FROM \_\_\_\_\_ DATE \_\_\_\_\_

MODEL/STOCK NO. \_\_\_\_\_