

Flying Model Rocket

Skill Level 2 Kit

For Experienced Modelers

- *Flies up to 900 ft. (274 m)*
- *14" dia. parachute recovery*
- *Die-cut balsa fins*

Super Cruiser[™]

This kit requires assembly. White glue, plastic cement, finishing supplies, launch system and rocket motors for launching are not included.

Item No. 2012

Length: 12" (30.48 cm)
Dia.: 1.25/.98" (25 mm)
Weight: 1.23 oz. (35 g)
Motors: A6-4 (first flight)
B6-4, C6-5

Assembled in Mexico



0 45856 02012 3

SUPER Cruiser



Product No. 2012

Skill Level Two



ASSEMBLY INSTRUCTIONS

Things You'll Need To Assemble This Kit:

Hobby Knife, Pencil, Paint Brush and Ruler



Sandpaper (220 or 320 Grit) & Sanding Sealer

White Glue

Aliphatic Resin glues work best such as TITEBOND or ELMER'S CARPENTER'S WOOD GLUE - ELMER'S WHITE SCHOOL GLUE also works but dries slower.

Plastic Cement

Use TESTORS TUBE Plastic Cement, PACTRA LIQUID CEMENT or other comparable brands. DO NOT use cyanoacrylate glue.

Tape, Paint and Wax Paper

Scotch Magic Tape or Paper Masking Tape, Spray Paint and Wax Paper.

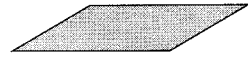

BEFORE STARTING ASSEMBLY READ THROUGH THESE INSTRUCTIONS. IT IS BEST TO TEST FIT ALL PARTS BEFORE APPLYING ANY GLUE. READ AND FOLLOW THE NAR MODEL ROCKET SAFETY CODE.

PARTS LIST

- A. 49000 Motor Clip
- B. 14000 Blue Thrust Ring
- C. 10303 Yellow Motor Mount Tube
- D. 14050 Red Centering Ring (2)
- E. 33027 Die-Cut Balsa Fin Set
- F. 11303 9" White Body Tube
- G. 20100 Plastic Nose Cone
- H. 20101 Nose Cone Base
- I. 10000 1 inch Launch Lug
- J. 50011 18 inch White Elastic Shock Cord
- K. 50051 18 inch Yellow Kevlar* Shock Cord
- L. 28107 14 inch Parachute
- M. 50100 Pack of 3-26 inch Shroud Lines
- N. 00500 Strip of 6 Gripper Tabs
- O. 02012-1030 Self-Adhesive Decal
- P. 02012-1010 Instruction Sheet

*Kevlar is a registered trademark of Dupont

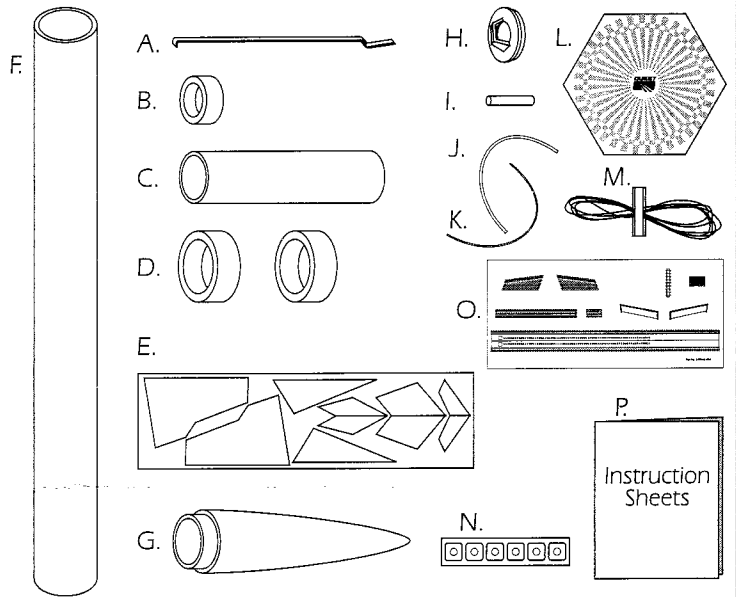

STEP 1

A. Apply plastic model cement (not white glue) around the inside edge of the plastic nose cone. Push the base into the nose cone. Set aside to dry.

B. Place the Blue Thrust Ring up against the side of the Yellow Motor Mount Tube and use it as a guide to make a small 1/8 inch long slit in the side of the Yellow Motor Mount Tube as shown.

C. Make a slight bend in the Motor Clip as shown. Insert the Motor Clip into the slit you made in the Yellow Motor Mount Tube.

Plastic Model Cement



Yellow Motor Mount Tube

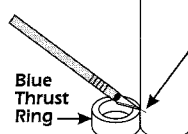

Make 1/8" Slit with Hobby Knife

Blue Thrust Ring

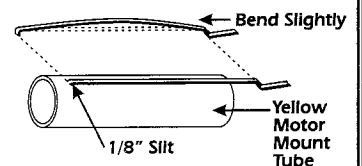

Bend Slightly

1/8" Slit

Yellow Motor Mount Tube

OVERLAP AREA

← WING

← LAUNCH LUG

← WING

TUBE MARKING GUIDE

STEP 2

A. Test fit one of the Red Centering Rings onto the Yellow Motor Mount Tube. If it does not slide on easily, stretch the Red Ring by sliding it over the Nose Cone and gently twisting it back and forth a few times. Slide the Red Ring onto the Yellow Tube just far enough to hold the Motor Clip in place.

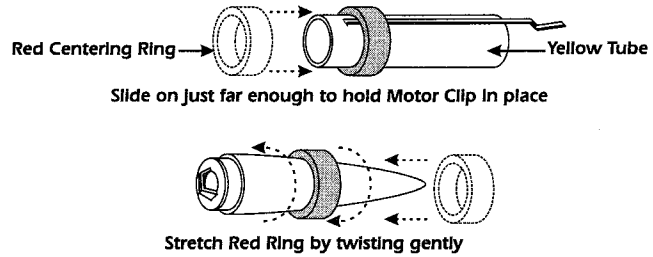

STEP 3

A. Apply a bead of white glue around the Yellow Motor Mount Tube 1/2 inch from the end as shown.

B. Slide the Red Centering Ring into the bead of glue. Wipe away any excess glue.

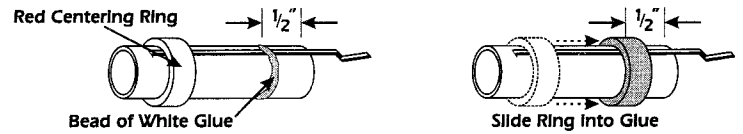

STEP 4

A. Tie two overhand knots 1 inch in from the end of the Kevlar Cord.

B. Pass the end of the Kevlar with the knot through the remaining Red Centering Ring.

C. Slide the Red Centering Ring with the Kevlar under it onto the Yellow Motor Mount Tube.

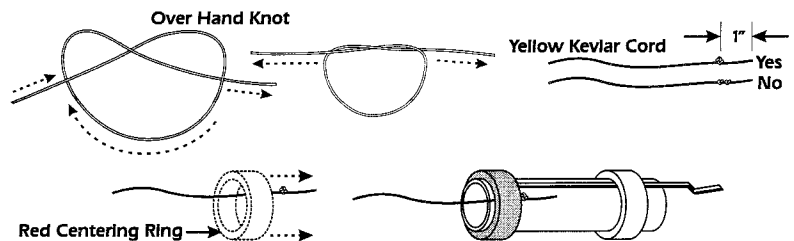

STEP 5

A. Apply a bead of white glue around the Yellow Motor Mount Tube 1/2 inch from the end as shown.

B. Slide the Red Ring into the bead of glue. Wipe away any excess glue.

C. Pull the Yellow Kevlar Shock Cord up tight against the Red Centering Ring.

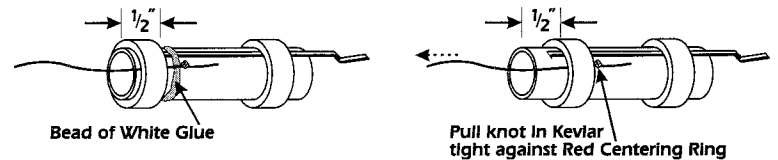

STEP 6

A. Apply white glue around the Yellow Motor Mount Tube 1/2 inch from the end as shown.

B. Insert the Blue Thrust Ring into the Yellow Motor Mount Tube so it is even with the end of the Yellow Motor Mount Tube.

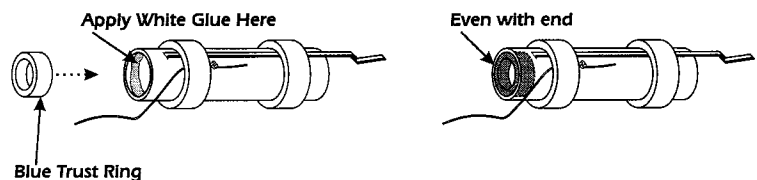

STEP 7

A. Hold the Yellow Kevlar Shock Cord and the White Elastic Shock cord side by side. Pull one end of each cord so that they are even with each other. While holding the two cords together, tie a single parallel overhand knot approximately one inch in from the ends as shown.

B. Gently pull on both cords to set the knot and prevent it from slipping.

C. Apply a small amount of white glue on the ends of both cords to prevent them from fraying.

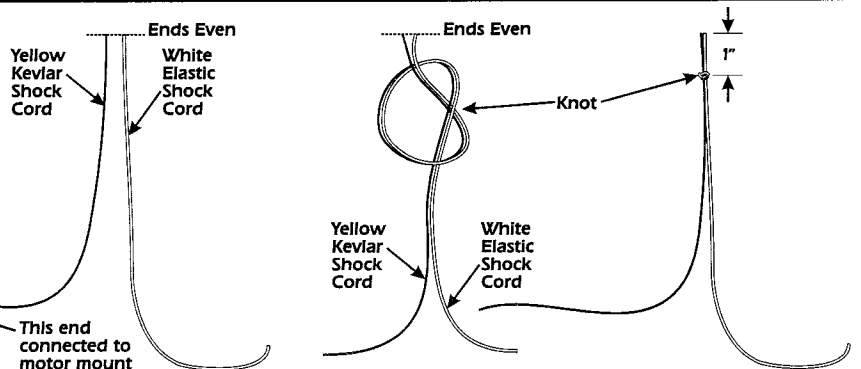

NOTE: THIS IS A VERY IMPORTANT STEP. IF YOU TIE A DIFFERENT TYPE OF KNOT THE SHOCK CORDS MAY SEPARATE DURING FLIGHT.

STEP 8

- Hold the Motor Mount Assembly and the White Body Tube in one hand.
- Apply White glue around the inside of the White Body Tube.
- Immediately insert the Motor Mound Assembly and PUSH IT INTO THE BODY TUBE WITH ONE FAST & SMOOTH MOTION until the Yellow Motor Mount Tube is even with the end of the White Body Tube.

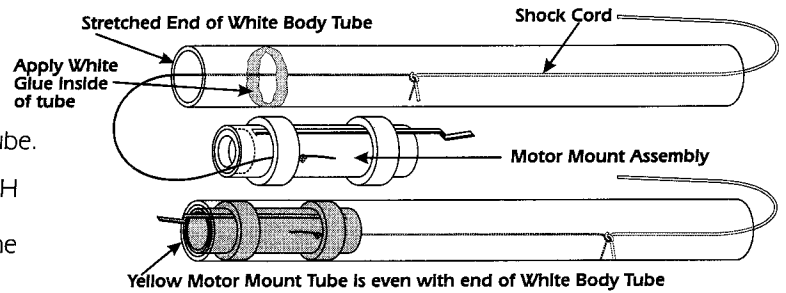

STEP 9

- Cut out the tube marking guide from the front page of this instruction sheet.
- Wrap the tube marking guide around the White Body Tube. Align the arrow that is marked "Launch Lug" with the Motor Clip. Mark the White Body Tube at each of the arrows with a pencil.
- Use a door frame as a guide and extend each of the pencil marks the entire length of the White Body Tube.

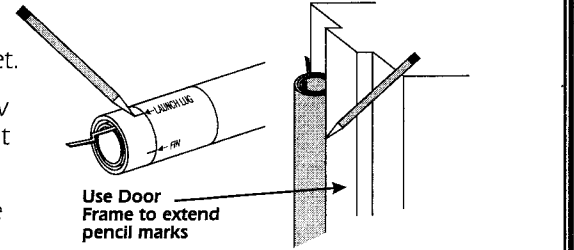

STEP 10

- Carefully remove each of the three die-cut balsa fins from the sheet with a sharp hobby knife.
- Stack the fins together and sand all edges smooth.
- Rub a small line of white glue into the root edge of each fin and set aside to dry.

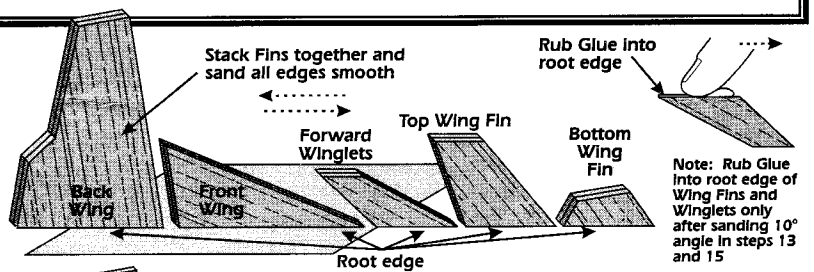

STEP 11

- Use white glue to assemble the wings over a piece of wax paper on a flat surface.
- Apply glue to the connecting edge of the smaller piece and push parts together over a piece of wax paper.
- Check the alignment of the root edge of the pieces by lining them up with the edge of a ruler. Allow glue to dry before handling the parts further.

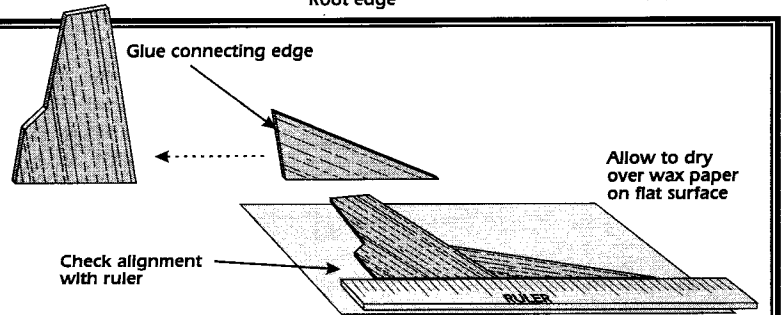

STEP 12

- Apply white glue to the root edge of a wing. Position it on the alignment line even with the end of the White Body Tube. Check to be sure it is projecting out from the Body Tube as shown. Let dry for a few minutes. Repeat procedure for the other wing.

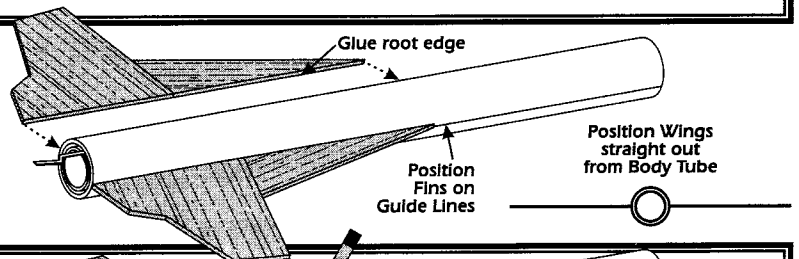

STEP 13

- After the wings are dry, use a pencil and ruler to draw a guide line on both the top and bottom of the wing as shown.
- Use a sanding block held at a slight 10 degree angle to bevel the root edge of the top wing fin and bottom wing fin.

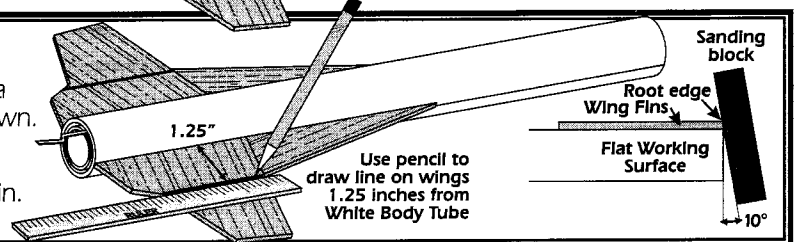

STEP 14

- Apply a small line of white glue to the root edge of a top wing fin and position it along the guide line drawn in Step 13. After glue sets, repeat for the other side Top Wing Fin.
- Apply a small line of white glue to the root edge of a bottom wing fin and position it along the guide line drawn in step 13. After glue sets, repeat for the other side Bottom Wing Fin.

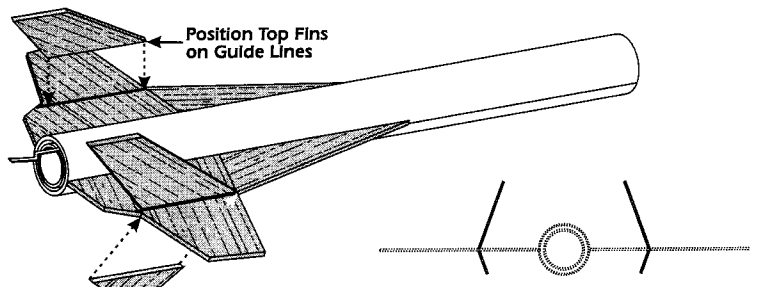

STEP 15

- Make a pencil mark $\frac{3}{4}$ inch back from the front edge of the White Body Tube on both wing lines.
- Using a sanding block held at a 10 degrees angle to bevel the root edge of the forward winglets as shown.
- Apply a small line of white glue to the root edge and position it along the wing line at the $\frac{3}{4}$ inch mark.
- After the glue sets, repeat for the second winglet.

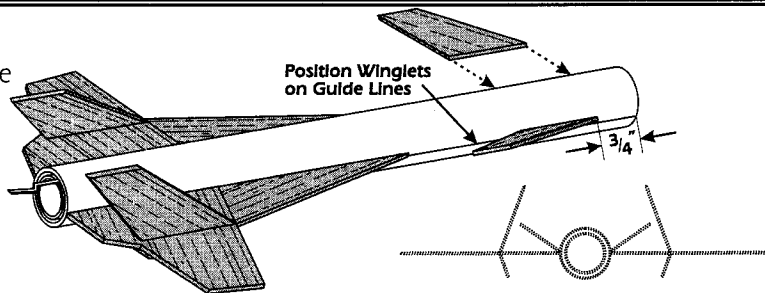

STEP 16

- After all the glue is completely dry apply a small bead of white glue to all the Wing/Body Tube joints. Smooth the glue out with your finger. Wipe excess glue off your finger into a tissue or paper towel.
- Apply white glue to the Launch Lug and place it straight along the pencil line centered between the two wings 4 inches from the end of the body tube.

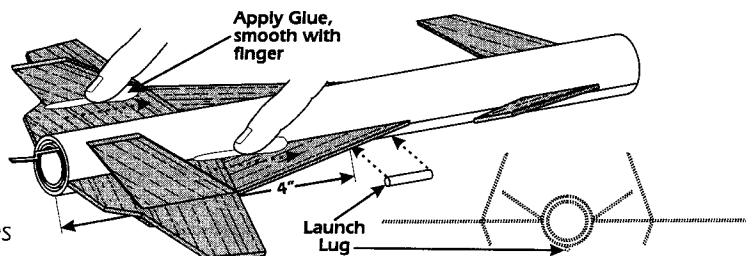

STEP 17

- Remove the Gripper Shroud Line Fasteners from the strip. Always handle Grippers by the edge so you don't touch the adhesive. Place the Gripper on one of the six corners of the Parachute.
- Firmly squeeze each Gripper and parachute material between your fingers.
- The Shroud Line is pre-cut into three equal lengths. Take one length of the Shroud Line, pass it through the hole in the Gripper and tie one end with two overhand knots. Tie the other end of the shroud line to the nearest Gripper. Repeat for remaining Shroud Lines.

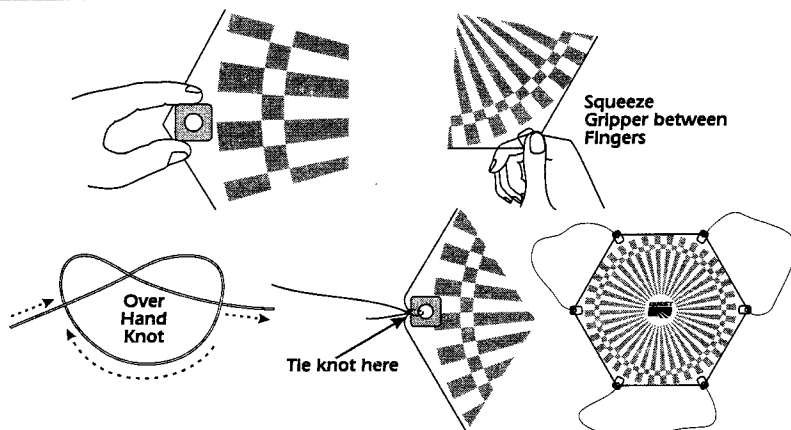

STEP 18

- Pass the Shroud Line Loops through the eyelet on the Nose Cone. Pass parachute through loop ends and pull lines tightly against the eyelet.
- Use two overhand knots to tie the loose end of the shock cord onto the base of the nose cone.

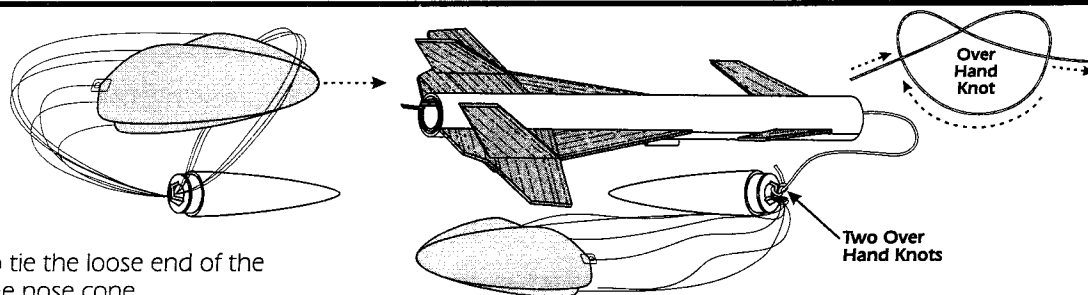

STEP 19

- After all the glue is completely dry apply a coat of sanding sealer to each fin. When sealer is dry, lightly sand each fin.
- Repeat the sealing and sanding process until the surface of each balsa part is smooth.
- Paint the entire rocket with gloss white spray enamel. Follow the instructions on spray can for best results.

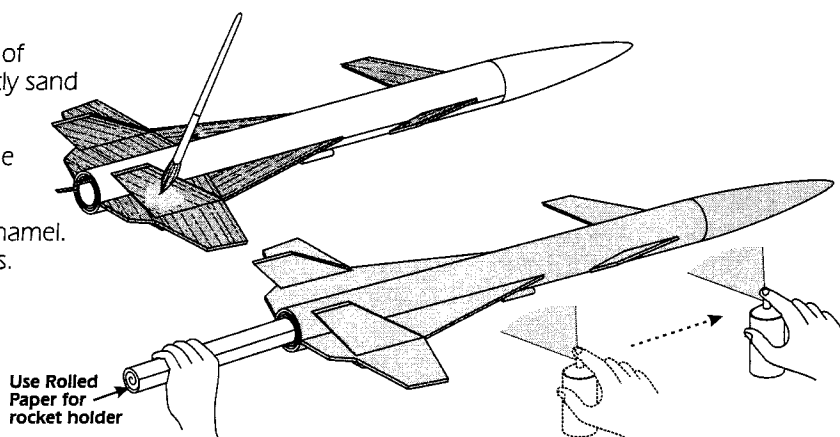

STEP 20

A. When all paint is dry, apply the self-adhesive decal as shown.

NOTE: Use caution when removing the decal from the backing to prevent decal from curling over onto itself.

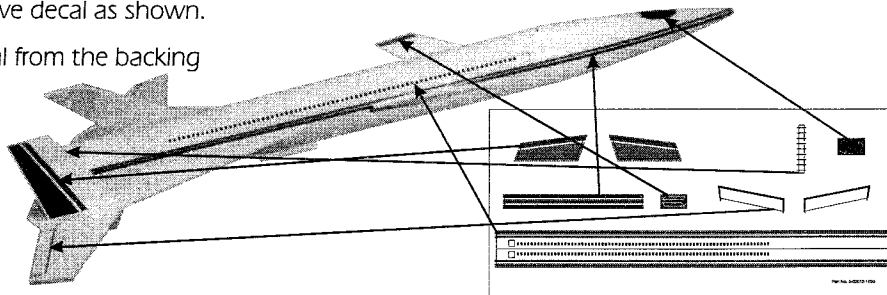

FLYING YOUR SUPER CRUISER ROCKET

WHAT ELSE YOU WILL NEED:

To successfully fly your rocket you will need the following items.

- QUEST Launch Pad (No. 7610)
- QUEST Launch Controller (No. 7510)
- QUEST Parachute Recovery Wadding (No. 7020)
- QUEST Rocket Motors, Type A6-4, B6-4, C6-5 or C6-7
- Use an A6-4 Motor for first flights.

ESTIMATED ALTITUDES:

The following is a guide to assist you in determining which motor to use based on the wind conditions and size of flying field available.

MOTOR	ESTIMATED ALTITUDE
A6-4	200 FEET
B6-4	350 FEET
C6-5	750 FEET
C6-7	900 FEET

PREPPING YOUR ROCKET FOR FLIGHT:

STEP 1

Pull the shock cord all the way out of the body tube. Crumble **three** sheets of recovery wadding and insert one by one into the body tube making sure that the knot between the Kevlar and White Elastic Shock Cord is on the Nose Cone side of the wadding. Wadding should fit loosely in the tube but tight enough to form a good seal against the wall of the Body Tube.

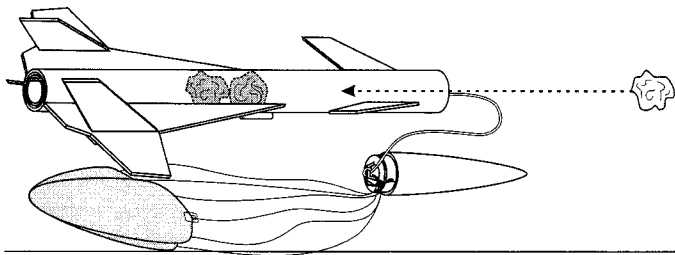

STEP 2

- Grab the parachute at its center and allow the rocket to hang from it. The weight of the rocket will pull the parachute into several triangular shapes.
- Gather the triangles together into one flat triangle.
- Fold the top of the parachute down over itself once.
- Now continue to roll the parachute over itself and roll the shroud lines around it.

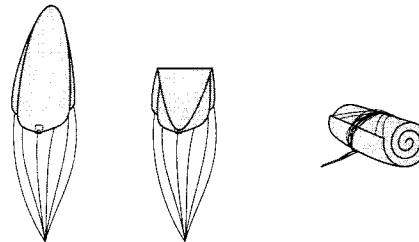

STEP 3

- Pack the parachute into the body tube. **THE PARACHUTE MUST SLIDE EASILY INTO THE TUBE** If it is a tight fit, remove and re-fold the parachute.
TIP: LIGHTLY DUST YOUR PARACHUTE WITH TALCUM OR BABY POWDER TO KEEP IT FROM DEVELOPING A SET SHAPE. THIS TECHNIQUE IS ESPECIALLY EFFECTIVE IF THE WEATHER IS HOT AND HUMID OR VERY COLD.
- Push the shock cord into the Body Tube and re-fit the Nose Cone onto the rocket. **BE CAREFUL NOT TO CATCH ANY OF THE SHOCK CORD BETWEEN THE SHOULDER OF THE NOSE CONE AND THE BODY TUBE.**

READ AND FOLLOW THE ENCLOSED LAUNCHING PROCEDURE SHEET

READ AND FOLLOW THE N.A.R. SAFETY CODE DURING ALL YOUR MODEL ROCKETRY ACTIVITIES.

© 2002 All rights reserved



Manufactured by:
QUEST AEROSPACE
A Division of
MARVEL ENTERPRISES, INC.
Yuma, AZ 85364

IGNITER INSTALLATION INSTRUCTIONS

Launch your model rockets by electrical means only. Use a Quest Launch Controller and Tiger Tail II igniters. Install Tiger Tail II igniter carefully, follow these instructions.

STEP 1

Remove Tiger Tail sticker from backing sheet.

Leave "dots" behind on sheet.

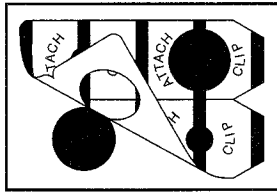

Step 2

Center the copper igniter wire over the hole.

Fold Tiger Tail sticker over the igniter wire.

Be sure igniter wire is centered and visible through both holes.

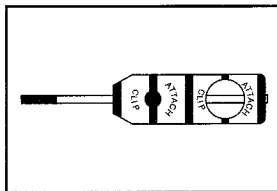
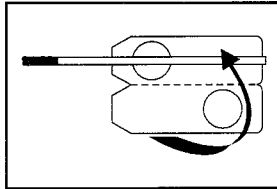

STEP 3

Place black coated end of the igniter wire into the motor nozzle as far as it will go. Black igniter tip **MUST TOUCH** the bottom of the nozzle or motor will not ignite.

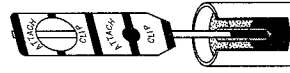

STEP 4

Push the plastic Tiger Tac into nozzle as far as it will go.

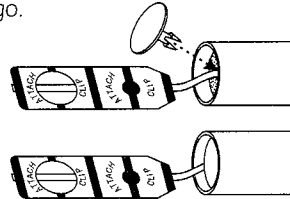

STEP 5

Insert rocket motor into rocket's motor mount.

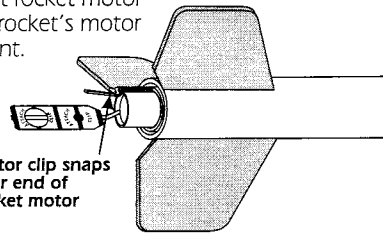

STEP 6

Slide rocket onto launch rod and position on launch pad.

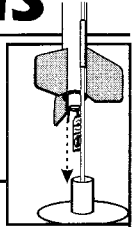

STEP 7

Attach one Micro-Clip lead to each hole where the copper wire is exposed.

Attach Micro-Clip lead on opposite sides of Tiger Tail II igniter.

Tie Micro-Clip leads to launch pad leg.

Use launch pad stand-off tube.

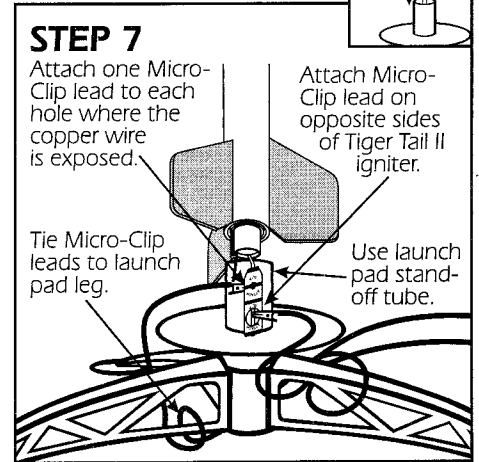

IMPORTANT: To avoid potential short circuit and/or misfire **DO NOT** clamp Micro-Clips too tightly to the Tiger Tail II Igniter.

NOTE: If you are using a different brand rocket motor and the Tiger Tac does not fit into the nozzle, substitute the Tiger Tac with a 1" x 1" square of recovery wadding crumpled into a small ball and pushed into the motor nozzle with a pen or pencil tip to hold igniter wire in place.

LAUNCH PROCEDURES

LAUNCH SITE SELECTION

Select a large area away from tall trees, power lines and low flying aircraft. Parks, playgrounds, soccer and football fields make great launch sites.

DO NOT LAUNCH ROCKETS IN AREAS WITH BROWN GRASS, DRY WEEDS, OBSTRUCTIONS OR ANY HIGHLY FLAMMABLE MATERIALS.

The larger the launch site, the easier it will be to recover your rocket. See the N.A.R. Safety Code for additional information.

NOTE: For circular area, site dimension is the diameter in feet, for a rectangle area, it is the shortest side in feet.

Motor Type	Installed Total Impulse (Newton-Seconds)	Minimum Site Dimensions (feet)
A	1.26-2.5	100
B	2.51-5.00	200
C	5.01 - 10.00	400

COUNT DOWN PROCEDURE

1. When your rocket is ready to launch, be sure you and all spectators are standing at least 15 feet away from launch pad.
2. Make sure the sky is clear of low flying aircraft. Wind conditions should be gentle. Be sure you have the attention of all individuals in the launching and recovery areas.
3. Arm your Launch Controller with the Safety Key. The arming light should go on. If arming light does not go on, check battery power, electrical connections and igniter installation. Clean the Micro-Clips with sandpaper if necessary.
4. With rocket armed, announce to the spectators in a loud voice, "the rocket is armed and counting ...5...4...3...2...1...Lift-Off!"
5. Push the launch button down momentarily until the rocket motor begins thrusting, then release it. The rocket should lift off from the launch pad almost instantly.
6. **BE SURE AND REMOVE THE SAFETY KEY FROM THE LAUNCH CONTROLLER AS SOON AS THE ROCKET LIFTS OFF.**

KEEP THE SAFETY KEY WITH YOU AT ALL TIMES.

7. REPLACE THE LAUNCH ROD SAFETY CAP IN BETWEEN LAUNCHINGS.

MISFIRE PROCEDURE

1. Occasionally, at the end of the countdown the rocket will fail to lift-off because the motor did not ignite. This usually occurs because the igniter was not making proper contact with the surface of the rocket motor's propellant.
2. Disarm the launch controller, wait one minute, then remove the model from the launch pad.
3. Remove the Tiger Tail II igniter from the motor nozzle, clean the micro-clips and install a new Tiger Tail II igniter.
4. Repeat the countdown procedure again.
5. If arming light glows, but motor does not ignite, try repositioning the micro-clips on the Tiger Tail II igniter and repeat the countdown procedure.

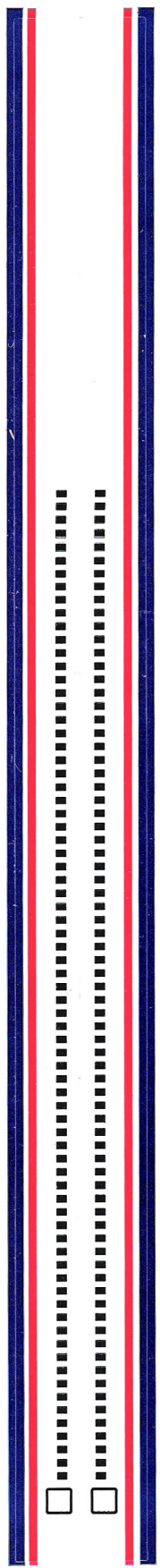
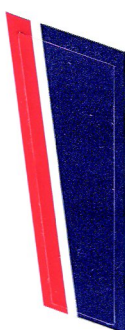
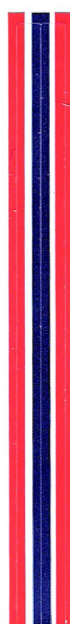
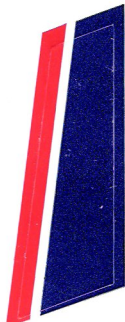
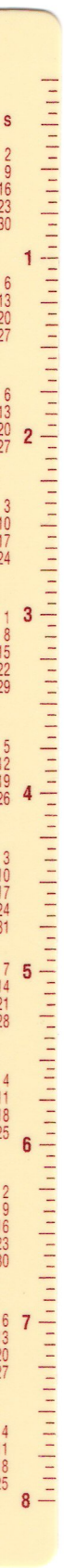



1

2

3

4

5

6