

# American Rocketeer

Centuri

Vol. 2 No. 1

Published by

Engineering Co.

Phoenix, Arizona

## NEWSLETTER NAMED

The editorial staff proudly announces that they have judged their way through the mountains of entries received in Centuri's "Name the Newsletter" contest. We wish to thank all of you who sent in entries. We sincerely appreciate your participation. There were so many good names submitted that it was extremely difficult to select just one.

Each entry was judged individually on the basis of originality, applicability to the Newsletter's aims, and date of entry. Many duplicate names were received, so the earliest entry date became the final deciding factor.

As you can see at the top of the page, our staff chose the name "American Rocketeer", submitted first by Michael Poss of Los Angeles, California. He will receive a Merchandise Certificate worth \$50 for any supplies out of Centuri's Catalog. Mike is a member of N.A.R., and the Arevalos Rocket Association of southern California. Congratulations Mike!!!

We wish to also give honorable mention to John Cerami of Oreland, Penn., for his #2 entry of the same name.



Mike Poss of Arevalos Section

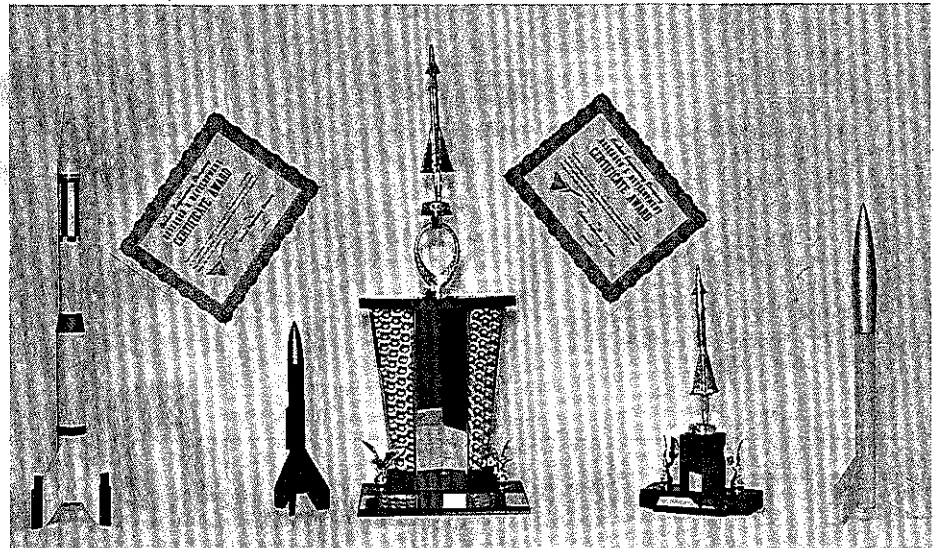

## DESIGN CONTEST SPARKS CREATIVE TALENT IN MODEL ROCKETEERS

Your response to our recent Design Contest was overwhelming. Among the thousands of entries received, were many excellent and useful ideas. We really appreciate the effort made by each contestant in presenting his design. While we would like to send you a personal reply with comments on each entry, we find this to be an impossible job, and would therefore like to use this newsletter to extend our congratulations and thanks.

Judging of all the entries was a tough job, but was extremely interesting and rewarding. By the quality of the entries received, it's very apparent that your generation will be prepared to meet the challenges of the Space Age. We'll be presenting some of the winning designs in our issues of A.R., and others may appear soon as plans. Still yet, a few more may even show up as new kits in our next catalog.

Congratulations for first place go to Edward La Croix, 13, of Wayzata, Minn. His design (page 3) is called "ANTARES Space Probe". Ed's entry contained complete assembly instructions, drawings, parts list, specifica-

tions, and color photos. Again, congratulations Ed for a job well done. Ed will receive a \$50 Merchandise Certificate and a large gold trophy inscribed with his name.

Second place winner is P. B. Zimmerman, 16, of Wash., D.C. His design, "LASER 244", will be illustrated in the next issue of A.R. He will receive a \$25 Merchandise Certificate plus a gold trophy. Third place goes to David Shindo, 13, of El Paso, Texas who designed "CANOPUS-IIB", a bi-boosted, rear eject recovery bird. He will receive a \$10 Merchandise Certificate.

In addition, twenty-five other deserving rocketeers will receive attractive Certificates of Achievement for their entries.

If you were not a winner this time, don't be discouraged. Keep trying to expand your design skills. Read about and observe the techniques used by professional rocketeers. Then apply these techniques to your model rocket designs using the hundreds of available Centuri parts. Perhaps next time you'll be a top winner.

# ROCKET CROSSWORD

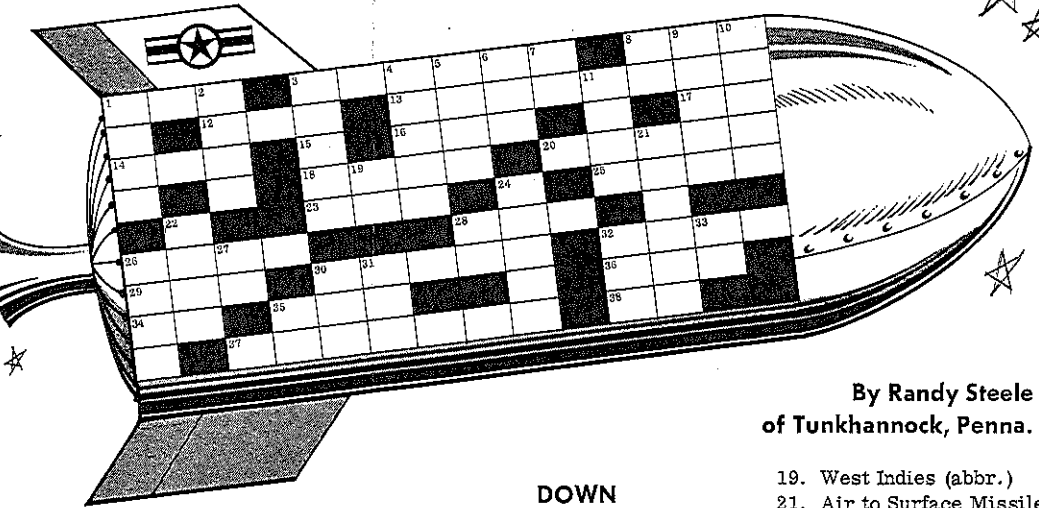
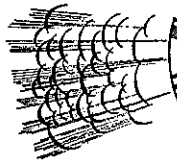

## ACROSS

1. Liquid Oxygen (abbr.)
3. Space Project
8. Sun's Name
12. Rodent
13. Explorer Satellite's Booster
14. National Aeronautic Assoc. (abbr.)
16. International Geophysical Year (abbr.)
17. South America (abbr.)
18. To Leave Army Illegally
20. To Drill Into (Pl.)
23. Evil
25. To Classify
26. \_\_\_ Kennedy Missile Base
28. Launcher
29. To Mistaken
30. Earth's Sister Planet
32. Healed Wound
34. North-South (abbr.)
35. FBI Associate
36. Egypt & Syria
37. 7th Planet From Sun
38. National League (abbr.)

## DOWN

1. Moon God
2. Radiation
3. First I. C. B. M.
4. Constellation Of Betelgeuse & Rigel
5. Legal (abbr.)
6. Land Yield (abbr.)
7. Old Style (abbr.)
8. South Ontario (abbr.)
9. Opposite of Offset
10. Contract
11. Agena Booster
19. West Indies (abbr.)
21. Air to Surface Missile
22. Red Planet
24. Past (Fr.)
26. Penny
27. Police Relations (abbr.)
28. Police University (abbr.)
30. Very Important Person
31. To Consume Food
32. Our Star
33. Argon (abbr.)
35. Civil Engineer (abbr.)

By Randy Steele  
of Tunkhannock, Penna.

## Would You Believe?

We're a bit late in getting out this issue of A. R. and we apologize. Newsletter writing and preparation turned out to be a bigger job than we counted on. We've been working hard concentrating on filling your orders and developing new products this year. And now that we've got the swing of things, we expect to publish a new issue at least every 3 months.

## PUBLISHER'S NOTE

The AMERICAN ROCKETEER is published by Centuri Engineering Company for its Customers and Friends to further acquaint them with the hobby of Model Rocketry and the new products and services it offers. It is sent free of charge to all Centuri customers from whom a substantial order has been received within the past six months. Remember, that your continued support by purchasing Centuri kits, engines, and supplies makes this newsletter possible. We welcome your comments and suggestions for improving and expanding the AMERICAN ROCKETEER.

Our Editor requests that news items, photos, and suggestions for new articles be sent to:

CENTURI ENGINEERING COMPANY  
American Rocketeer Publications  
P. O. Box 1988  
Phoenix, Arizona 85001

## HOW MODEL ROCKETRY CAN LEAD TO A CAREER IN AEROSPACE ENGINEERING

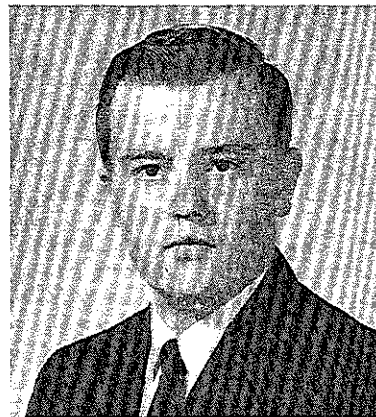

By John Huerkamp  
of New Orleans, Louisiana

If you are interested in model rocketry as a hobby, you probably enjoy building things; if, in addition to constructing model rockets, you are interested in some of the other phases of rocketry - the U.S. man-in-space program and the anti-missile defense system, for example - you could be headed toward a career in aerospace engineering.

In addition to enjoyment, model rocketry provides the basic principles so necessary in an aerospace engineering career. It introduces you to phases of ballistic flight,

rocket engine operations, the use of math and trigonometry in advanced drag calculations, altitude determination, and the designing of stable rockets, and myriad other concepts in the aerospace field.

If you feel that you have the ability to pursue an engineering curriculum later on, here are a few helpful suggestions: (1) Read all you can about rocketry in magazines, periodicals, newspapers, and books. (2) Develop interesting and original rocketry projects for school science fairs. (3) Don't neglect your academic subjects; there's plenty of time for both your hobby and your school responsibilities.

How do I know that these suggestions are practical? Well, only four years ago the rocketry "bug" bit me. Since then I've become a rocketry "nut". I am now attending Tulane University and my encouraging report card indicates that in June 1970, I'll receive that coveted B.S. in Engineering degree with a specialty in aerospace.

If you are willing to sacrifice a few other things for your model rocketry pursuits, you may become the engineer who will design the rocket that will land Americans on Mars.

# Design Contest WINNER

The "ANTARES Space Probe", first place winner in Centuri's recent Design Contest, is truly a rewarding model to build and fly. Using standard Centuri parts, the ANTARES is easy to build and will carry up to one ounce of your favorite payload.

## 'ANTARES' SPACE PROBE

Designed by EDWARD LA CROIX - Age 13, Wayzata, Minn.

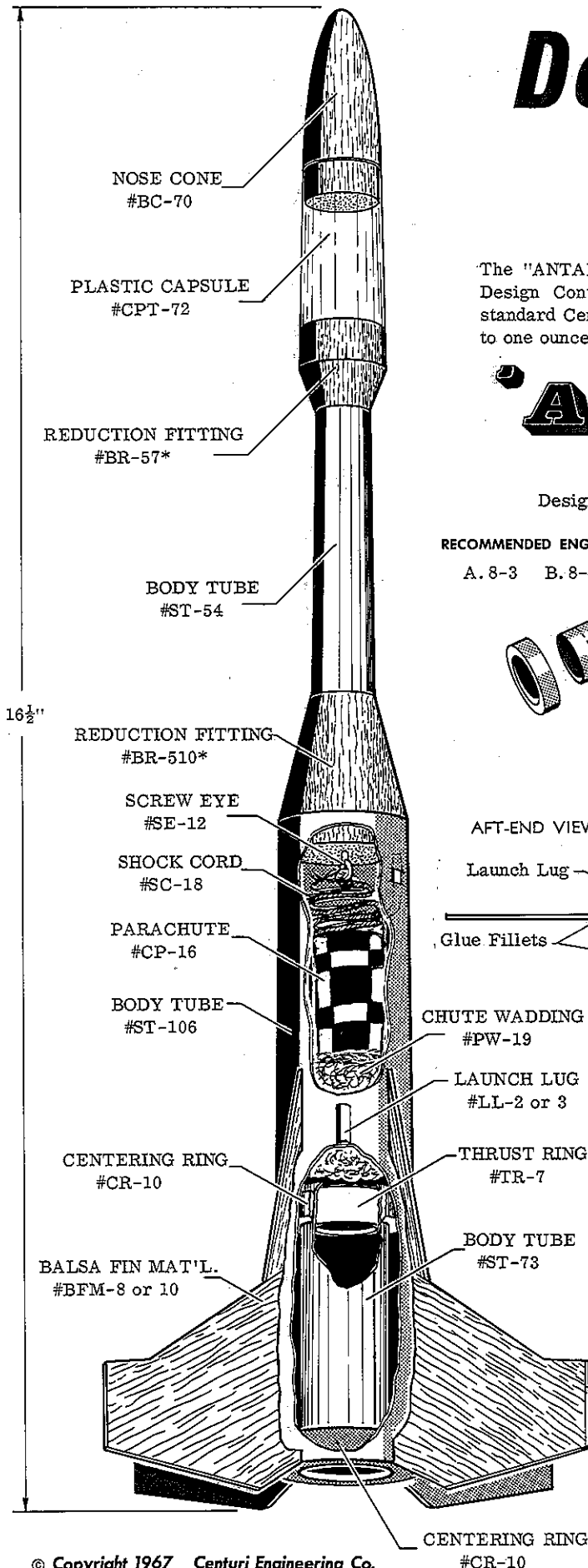

### RECOMMENDED ENGINES

A. 8-3 B. 8-4

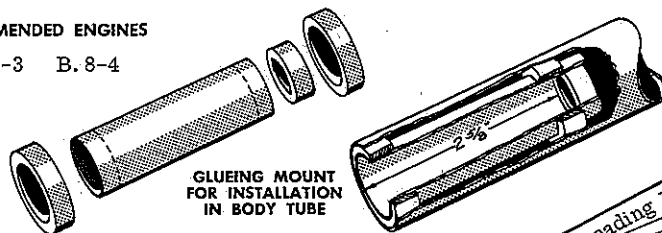

### AFT-END VIEW

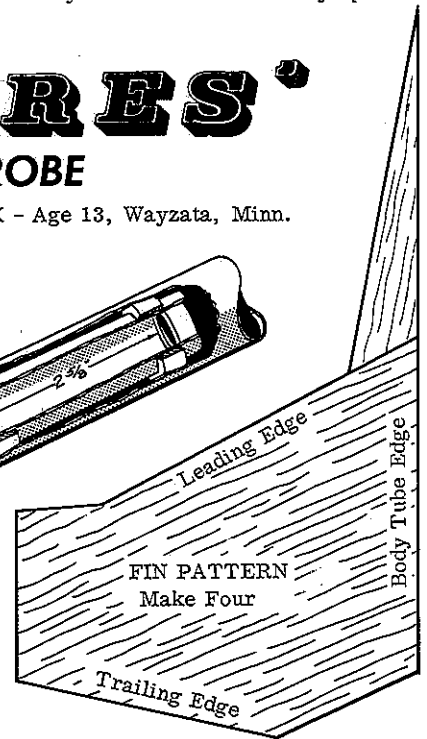
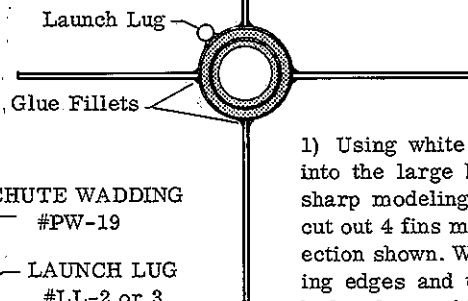

- 1) Using white glue, assemble and glue engine mount into the large body tube as shown above.
- 2) Using a sharp modeling knife and the pattern above, carefully cut out 4 fins making sure balsa grain runs in the direction shown. With fine sandpaper, slightly round leading edges and taper trailing edges.
- 3) Glue fins on body tube, making sure they are lined up properly.
- 4) Both balsa reductions should fit tightly into the #54 body tube.
- 5) Thread and glue screw eye into base of BR-510. Tie shock cord and chute shrouds to eye. Glue other end of shock cord between slits in body tube.

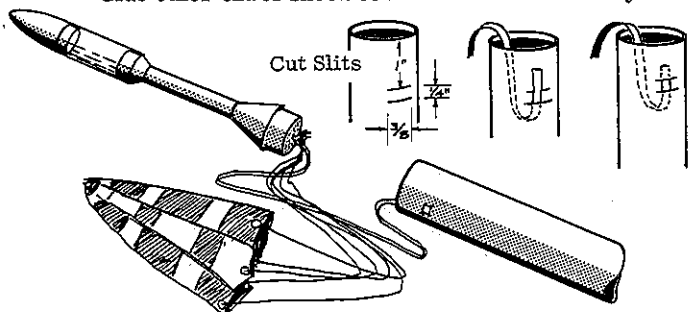

\*PLEASE NOTE: While not shown in 1967 catalog, these new Balsa Reduction Fittings are now available:  
BR-57 Adapts #5 to #7 Series 30¢ each  
BR-510 Adapts #5 to #10 Series 35¢ each

# ROCKET CLUB NEWS

## CONNECTICUT ROCKETEERS STAGE N.A.R. AREA MEET



Launching Range near New Canaan, Conn.

On May 14th, an NAR sanctioned Area Meet was held between SPACE PIONEERS Section of New Canaan, Conn., CHESHIRE Section of Cheshire, Conn., and FAIRCHESTER Section of Stamford, Conn. Twenty-five contestants and their parents met on the grounds of the Lapham Estate in New Canaan for the all day affair.

Dozens of scale "birds" were launched. In particular prominence were many scale I.Q.S.Y. TOMAHAWKS built with Centuri #8 series parts. Contest director and advisor to SPACE PIONEERS, G. Harry Stine was assisted in the meet by section president, Charles Duelfer (Fairchester) and Joe Persio (Cheshire).



Preparing Models for Launch



Range Communications

## MacArthur Rocket Society Presents Evening Programs

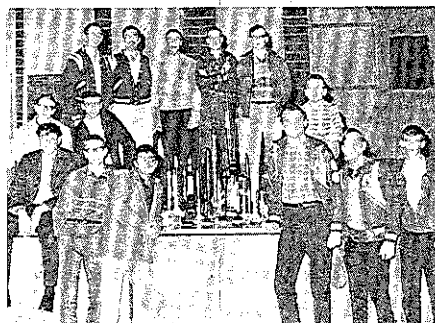

The late spring of 1966 found two of Irving, Texas', MacArthur High School juniors discovering model rocketry, and they found it such a fascinating hobby that they decided to share it with their friends. The result was the MacArthur Rocket Society, founded in September of 1966. The M.A.R.S. was received enthusiastically by students and faculty alike; both offered the two founders opportunities which they hadn't dared to hope for.

A high school is the ideal home for a model rocket society for several reasons. First, the sponsor can come from the school's advanced science teachers. A physics or chemistry teacher's training is a gold mine of information on the theory of rocketry. He can also make the school labs available to the club for supervised research. The M.A.R.S. also has at its disposal the school cafeteria for before-school business meetings and student parking lot-football field complex as a central location for Saturday morning launch sessions. If your high school is any size at all, you should

Turn to "M.A.R.S." on page 10

## Arevalos Rocket Association

A Leader in California Model Rocketry  
By Michael Poss

The Arevalos Rocket Assoc. of Southern California has been a chartered section of the National Association of Rocketry for nearly two years and has grown to become one of the largest N.A.R. sections in the United States. Now containing 70 members, Arevalos is growing more as science minded Californians become a part of ARA's model rocketry program.



Rockets on Multiple Launcher

Originally organized by Mr. Larry Holliday who still holds the position of "adult sponsor", ARA is headed up now by club president Bruce Williams of Costa Mesa, Calif.

The last official contest, ARA-2, took place on June 10th at the "HOLF Mile Square" site in Fountain Valley, Calif. and lasted for five hours. Recently obtained, this area is in constant use during the week by the U.S. Marine Corps for helicopter flight training. Arevalos also has two other widely separated launch sites in Southern California which it can alternate to in the event of bad weather at "Mile Square".

In addition to rocket launchings, Arevalos holds workshops and technical meeting sessions conducted by advisors Ace Erickson and Doug Malewicki. Their next launch meet is scheduled for October 28th at "Mile Square" with members of the West Covina Model Rocket Society competing against ARA.

Model Rocketry is growing fast in the Golden State. Nearly a dozen clubs in the Los Angeles area alone compete against each other regularly. If you are an enthusiastic rocketeer in Southern California interested in getting started, the ARA invites you to join its ranks. Contact Mr. L. D. Holliday, 19692 Lexington Lane, Huntington Beach, California, 92646.

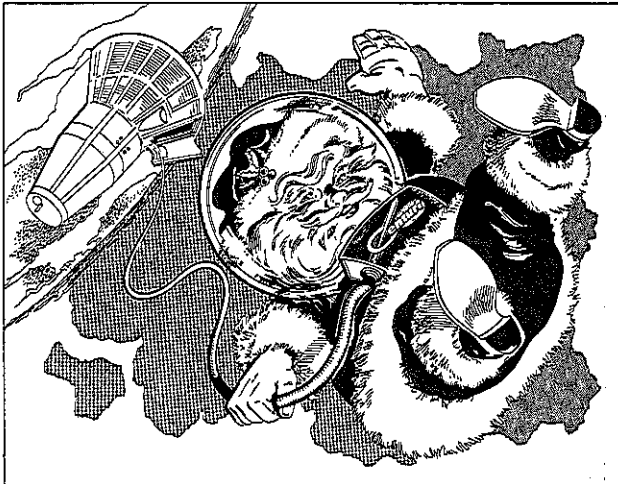

# HOLIDAY GREETINGS

FROM YOUR FRIENDS AT CENTURI

We at Centuri have truly enjoyed serving you during the past year, and wish to thank you for your continued interest and loyalty. Through Model Rocketry, thousands of young men have touched the reality of the Space Age and been inspired to seek a rewarding career in the Aerospace field. It is truly gratifying to know we may have had a small part in that inspiration. All of us here at Centuri wish you and your family a Merry Christmas and a healthy and prosperous New Year.

*Merry Christmas & Happy New Year*

## CENTURI WANTS YOUR CLUB NEWS

Yes, here at Centuri we really do want to hear about your club's activities. Even if your club is small, we're keenly interested in hearing about your launchings, demonstrations, field trips, and meetings. If you have a club bulletin or newsletter, please put Centuri on your mailing list. Have newspaper stories, photos, or other publicity appeared about your group? If so, please send us a copy.

Each issue of Centuri's American Rocketeer will include a section on "Club News". For each club news used, Centuri will award the club a \$10 Merchandise Certificate. Send us a brief description of your club's history, its activities, where you launch, types of competition events held and the member's names and addresses. For every story used, we like to include photos.

If you take pictures of your own group, be sure to make each shot interesting. Include the members of your group and the Centuri models you've built or are launching. Remember, we're interested in seeing Centuri products in use. Make sure your photos are black and white and have good contrast. As photos in newsclippings do not reproduce well in our newsletter, be sure to send a copy of the original photograph itself.

Who knows, maybe your club will receive nationwide publicity in our next issue of AMERICAN ROCKETEER.

## Centuri Looking for Writing & Engineering Talent

Centuri Engineering Company is now looking for both full-time and part-time Tech Writers and Model Designers. Experience in journalism or engineering technical writing is preferred. Model, parts, and equipment designers are also needed. Interested? Send us your resume, together with examples of your writing or designing abilities.

## Steel City Rocket Section Hosts 2nd Annual Spring Convention



LIFT-OFF!! Launching on ball field at Shady Side Academy—Spectators on hill to right

On March 17-19th, the Steel City Section of the National Association of Rocketry hosted their Second Annual Spring Convention at the Shady Side Academy in Pittsburgh, Pa. Over 120 model rocketeers from eleven states attended the 3-day meet where they participated in Technical Group Discussions, witnessed a N.A.S.A. Spacemobile Demonstration, and launched model rockets.

subjects ranging from "How to Form a Rocket Club" to "Advanced Model Rocketry With Electronic Payloads".

In spite of sub-freezing temperatures and winds, the rocketeers managed to launch quite a few "birds". One 'F' powered rocket with parachute deployed was last seen drifting into the next county.

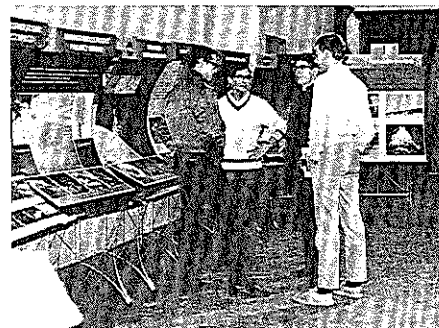

N.A.S.A. Exhibit

Housing for the 3-day meet was in the dormitories at the Academy with meals served in the Dining Hall. Various technical discussion groups, led by model rocket manufacturers including Centuri President Leroy Piester, and advanced rocketeers, tackled



Group Study Sessions

The Steel City Section itself has 34 members and is one of the most active in the country. Club president Bob Moeller together with his assistants Jay Apt and Arnold Pittler are already making plans for the 3rd Spring Convention scheduled for March 16th thru 18th of next year.

# New



# Products

**I. Q. S. Y.  
TOMAHAWK  
Sounding Rocket**

**1/10th  
SCALE MODEL**

- AUTHENTIC MARKINGS
- HI ALTITUDE FLIGHTS
- PARACHUTE RECOVERY
- ACCURATE SCALE

**SPECIFICATIONS**  
Length----20"  
Diam. ----.906"  
Net. Wt. --1.15 oz.

**Scale Detail  
by  
G. Harry Stine**

**#225**  
Postpaid  
**Catalog No. KC-40**  
Shipping Wt. 14 oz.

**Recommended Engines**  
A. 8-3    B. 8-4

Easy-to-build Scale Model. Excellently proportioned. Toppoint winner at Naram-9. Exact scale detail and assembly instructions provided. Flights over 1200 ft. with 'B' engine. Recovers safely with colorful 16" parachute.

## New Plastic Capsule Tubing

Use shorter lengths for see-thru biological payload capsules - longer lengths for see-thru display models showing the internal construction and recovery system. Fits perfectly with Centuri cones, couplers, and reduction fittings. Extremely thin-walled and lightweight.

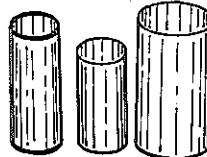

| Cat. No. | Fits Part #'s | I.D.  | Length  | Prices |        |
|----------|---------------|-------|---------|--------|--------|
| CPT-71   | #7            | .715" | 1-7/8"  | .10 ea | 3/.25  |
| CPT-72   | #7            | .715" | 2-3/4"  | .15 ea | 3/.30  |
| CPT-73   | #7            | .715" | 3 1/2"  | .15 ea | 3/.30  |
| CPT-78   | #7            | .715" | 8"      | .30 ea | 3/.60  |
| CPT-82   | #8            | .865" | 2 1/2"  | .15 ea | 3/.30  |
| CPT-83   | #8            | .865" | 3 1/2"  | .20 ea | 3/.45  |
| CPT-811  | #8            | .865" | 11 1/2" | .35 ea | 3/.85  |
| CPT-102  | #10           | 1.00" | 2 1/2"  | .15 ea | 3/.30  |
| CPT-103  | #10           | 1.00" | 3 1/2"  | .20 ea | 3/.45  |
| CPT-1010 | #10           | 1.00" | 10"     | .35 ea | 3/.85  |
| CPT-1018 | #10           | 1.00" | 18"     | .60 ea | 3/1.35 |

**New!!** **Special Formula**

### Model Rocket Glue

**Fast Drying**  
**Over Twice as Strong as White Glue**

The most perfect glue ever developed for model rockets. Sets much faster than white glue. Unbelievable strength. Use on balsa wood, paper and fabric. Sands extremely well.

**GL-100 1 1/4 oz. Squeeze Bottle 40c**

## New!! CHUTE PAKS

Includes two color canopy, shroud lines, tape discs, and complete instructions showing how to assemble, fold, and pack into model rockets.

### Big 24" Canopy Diameter

CP-24 Red & White    **50c ea.**  
CP-24A Black & Yellow

Also new CP-16B (Red & Yellow 16" Canopy) 35c ea.

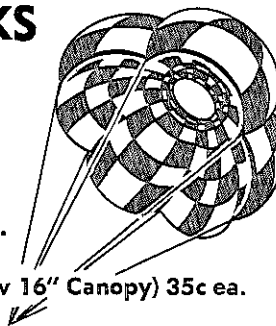

**SUPERFINE  
SANDPAPER**  
for that  
**Mirror-Gloss Finish**

Ideal for finish sanding on balsa fins, nose cones, and reductions. Used exclusively in Centuri's model building dept. Outlasts most other sandpaper. 6 sheet pak includes 2 - #400 grit, 2 - #320 grit, 2 - #280 grit, measuring 3" x 5 1/2".

Assortment Pak  
**FM-20..... 25c/pak**

**New!!** **"SURE-SHOT"** **Igniter**

**Reliable!!**

**At Last—A Reliable Engine Igniter for both Single & Clustered Engines**

Positive engine ignition every time. Solves the problem of simultaneous ignition of clustered engines. Comes in kit form -- assemble in seconds. Complete instructions for assembly and use.

**IG-12    Kit to make 12 Igniters    50c**

\*Patent Pending

More New

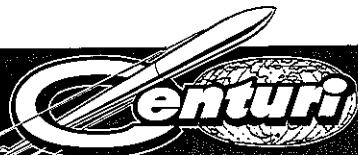

Products

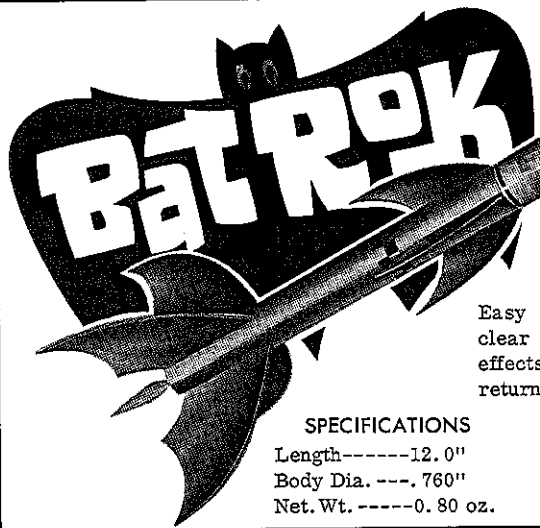

**Payload Carrier Rocket**

- BAT-LIKE DESIGN
- PAYLOAD CAPSULE
- PARACHUTE RECOVERY

Easy to build!! Carry your payload in clear plastic capsule. Study acceleration effects on insect life with assured parachute return. Complete with decals and 12" chute.

**SPECIFICATIONS**

Length-----12.0"  
Body Dia. ----.760"  
Net. Wt. -----0.80 oz.

**\$1.95**

Recommended Engines  
A-8-3  
B-8-4

Cat. No. KB-8

**Parachute Powder**

DRY LUBRICANT for PLASTIC CHUTES



Aids chute in opening and creates dust cloud upon chute ejection to aid in tracking.

PDR-17 2-oz. Shaker Can 60c

Stop Scorching! Sticking of Plastic Parachutes

**CHUTE PROTECTOR WADDING**



Flame Resistant  
Sufficient wadding for 20+ flights

PW-19 .....35c Pkg.



**FREE!!**

Now with every\* order from Centuri

**BOOK & BUMPER STICKERS**

Use on: Books - Car Bumpers

\* Bicycles - Field Boxes - Range Gear

Get Yours today with your min. \$2.50 Order

**GIANT BARGAIN BOX**



A real bargain for that rocketeer with ingenuity and craftsmanship. This bargain box contains usable "seconds", rejected because of slight defects such as "oversize", rough spots, small dents, etc. Included are body tubes, nose cones, sheet balsa, parachutes, etc. Typical bargain box is shown above. Quantity Limited.

Catalog No. SP-10 **\$3.00** Postpaid

**THE WORLD'S SMALLEST TWO-STAGE ROCKET**

- Hi Altitude Flights
- Launch Many Times
- Streamer Recovery

**\$1.50**

No. KA-6  
Shipping Wt. 8 oz.

Length----- 9.0"  
Dia. ----- .906"  
Net. Wt.-0.90 oz

Recommended Engines  
Booster      Sustainer  
1/4A.8-0S    1/4A.8-4S  
1/2A.8-0S    1/2A.8-4S

Real 2-stage operation!!! The Firefly streaks nearly out of sight, then returns by colorful streamers. Booster tumble recovers. Fly top stage by itself with 1/4 or 1/2A.8-4S engines. Complete with decals.

**BAG 'O' Balsa**



Hundreds of Uses  
Make Your Own  
Nose Cones

Dozens of uses. Turn your own nose cones from balsa blocks. These blocks, ranging in length from 2 1/2" to 5 inches and measuring 3/4" to 1 1/2" square are end pieces from Centuri's automatic nose cone making operation. All are perfectly useable for making your own nose cone designs. Includes instructions on "How To Make Your Own Nose Cones".

Catalog No. SP-15 \$1.00 Postpaid

**FREE!!**  
**"Firefly"**  
2 Stage Rocket Kit  
With your order of \$7.50 or more  
See Coupon on wrapper

Centuri's

**ROCKET PRO/STRIPE**

TRIMMING TAPE

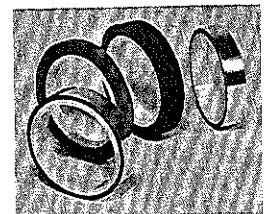

- Fluorescent
- Metallic
- 8 Colors

Available in 1/8" & 1/4" Widths

Please Specify Color & Width

Create brilliant stripes, bands, and roll patterns on your models. Easy and fast to apply. 100" length on 1/8" rolls, and 75" on 1/4" rolls. Please specify both color and width. Colors available are:

- |        |                  |
|--------|------------------|
| Red    | Fluorescent Red  |
| Black  | Fluorescent Pink |
| White  | Metallic Chrome  |
| Copper | Metallic Gold    |

TT-9 25c per roll 3 Rolls for 65c

# Vice President & Astronaut Visit Rocketeers at 9th Annual Model Rocket Meet

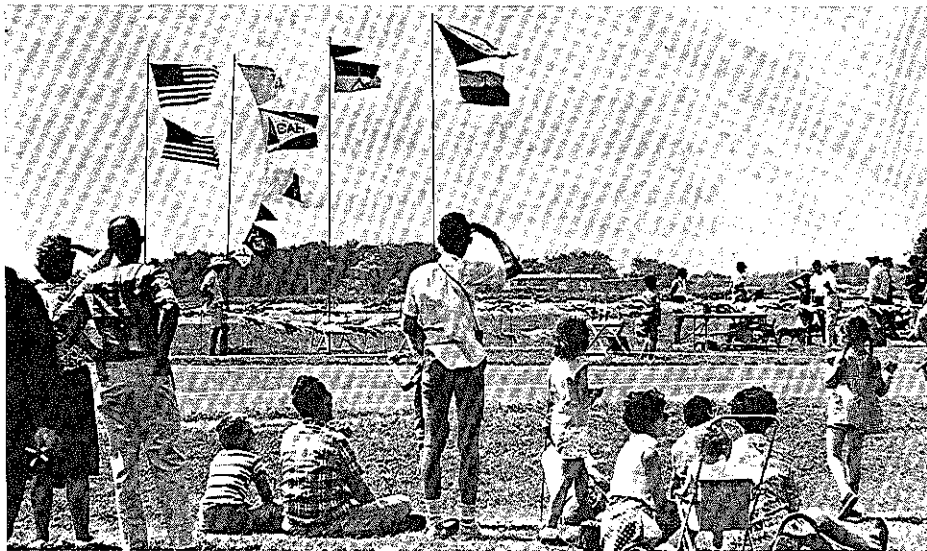

Spectators about to view lift-off from launch area

Each year in August, top ranking rocketeer members of the National Association of Rocketry (NAR) from all over the country, meet to compete with each other for national honors and trophies. This year, the 9th Annual Model Rocket Championship Meet, called NARAM-9, was held at the municipal airport in Mankato, Minnesota, August 15th thru the 18th.

Hosted by NAR's Zenith Section of Mankato, and directed by Dr. Ellsworth Beetch, this year's competition saw the nation's top rocketeers set records in such events as:  
Parachute Duration - Aerospace Systems  
Boost-Glide Duration - Spot Landing  
Scale Altitude - Plastic Scale  
Payload Lifting - Research & Development



Multiple Rod Launcher

Competition in each event was divided into the following age groups:

- Junior Members - under 17 years old
- Leader Members - 17 thru 20
- Senior Members - 21 and older

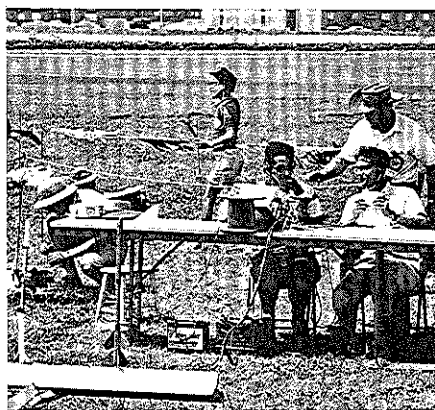

Launch Control Center

NASA Astronaut Lt. Commander Thomas K. Mattingly was guest of honor at the opening ceremonies. Astronaut Mattingly launched the first model rocket to begin national competition before several hundred NAR contestants, officials, and spectators.

When a reporter ask after a day's launchings, "Are they learning anything?", Astronaut Mattingly replied with a definite "Yes", and added, "If I were a young man growing up at this time, I would be out there - - or at least I'd like to be there. What they're doing today relates back to what I did as a youth with model aircraft. NAR members obviously experience technical training which provides a rare practical approach to astronautics."



Lift-Off!!

NASA's official representative Astronaut Mattingly commented on a delay caused by a malfunction in the firing system before the first rocket streaked skyward, saying, "This is a good example of what happens when those who pursue the aerospace field solve a problem in the system. Just as we learned in our space program, these young rocketeers here have learned that reliability is more important than sophisticated systems."

Astronaut Mattingly was present throughout the first two days of the meet visiting with rocketeers, answering questions about astronautics, and signing autographs. It was easy to see that Commander Mattingly, a full scale rocketeer, enjoyed watching smaller scale model rockets lift-off the pads and streak skyward.

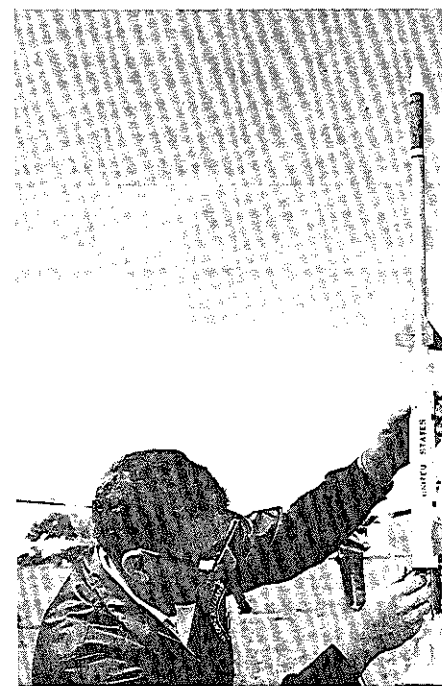

Jim Barrowman preps for launch





**Altitude Tracking & Communications**

Centuri president Leroy Piester, his wife Betty and 4 year old son, Ricky were present at NARAM to meet and talk with rocketeers and visitors. Centuri staff member, John Bradford explained the various rocket models, launchers and ignition devices on display at the Centuri booth. Mr. Piester presented thrilling flight demonstrations of MINI-MAX powered rockets launched to high altitudes followed by perfect parachute recovery.

Housing for contestants in the four day meet was in the dormitories of nearby Mankato State College. One of the real highlights of this meet, was the interpersonal exchange of ideas, both out on the launch range and in the evening dormitory "skull sessions".

On the final day, after the close of competition, an Awards Dinner was held at Mankato College. Featured guest speaker at the Awards Ceremony was Vice President



**Hooking up Ignition Leads**

Hubert H. Humphrey who spoke about Dr. Robert H. Goddard's early work in rocketry 41 years ago, and how his contributions started this country toward the Space age.

He advised all young rocketeers to prepare now for their higher education, and added, "We hope to see a lot of you in years to come in our space effort. We hope to see you in our laboratories, and our private industries, and our great universities, and we hope to see some of you in government!"



**Scale TOMAHAWK**

Vice President Humphrey who is also Chairman of the National Aeronautics and Space Council, commended all the rocketeers present saying, "Young people of today are living in the most exciting period of human history, and the last third of the 20th Century is going to see more progress and more change than all the preceding years up to now. I want to encourage the young people here to, as we say, get with it cause you're where the action is when you're with the space age and the age of rocketry."



**Heads Up in the Launch Area**

Handsome trophies, plaques, and ribbons were handed out to 1st, 2nd and 3rd place winners in each event and in each age group. The six top awards went to:

**SENIOR**

- G. Harry Stine - National Champion
- Carl Feldman - Reserve Champion

**JUNIOR**

- Charles Duelfer - National Champion
- Bill Block - Reserve Champion

**LEADER**

- J. Talley Guill - National Champion
- Joe Persio - Reserve Champion

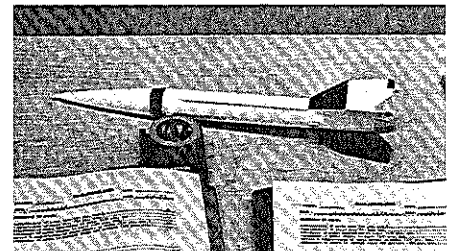

**Scale Model MX-774**

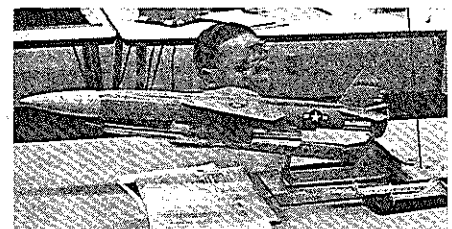

**Scale BOMARC**

Again, just as in past years, the NARAM was a roaring success. The American Rocketeer will carry news of the coming NARAM-10 next summer.

Our congratulations to Dr. Ellsworth Beetch, professor of chemistry at Mankato State College who was elected the new president of the National Association of Rocketry by the NAR Board of Trustees. He replaces retiring president G. Harry Stine who deserves tremendous credit for his past years of untiring service and invaluable contributions to the hobby of Model Rocketry.



# TECH TIPS

## Rocket Engine Thrust

Many rocketeers have expressed concern that since Centuri's blast deflectors are slanted, they do not provide a very good surface for the rocket engine to thrust against as it leaves the pad.

Rocket engines do not require anything to thrust against in order to leave the launch pad. In fact, the exhaust gases "pushing away" from the rocket create the thrust. Burning propellant within the engine chamber generates expanded hot gases which create high pressure within the chamber.

MODEL ROCKET ENGINE



$P_c$  = Pressure in Chamber  
 $P_a$  = Pressure of Atmosphere

Gases always flow from regions of higher pressure to regions of lower pressure. The gases within the combustion chamber are pushing against the front of the chamber wall but are free to leave through the rear end of the chamber. This unbalanced pressure results in thrust.



This principle can be illustrated simply by blowing up a balloon and then letting go of it. The air pressure at the nozzle end is free to escape and the unbalanced pressure creates thrust and causes the balloon to move forward.

## MODEL ROCKETS for CHRISTMAS (Gift Certificates Available)

There isn't a more appreciated Christmas gift for that young Rocketeering son or friend of yours than a new Rocket Outfit or kit with engines. However, if you're not sure just what to order for him, let him do the selecting with a Centuri Gift Certificate. Simply fill out the enclosed Gift Certificate Request from the newsletter wrapper and mail to us now.

We guarantee delivery by Christmas, anywhere in the U.S. or Canada if your request is mailed to us by December 18th. An attractive bond-like Certificate will be mailed to him immediately with our latest 1967 catalog. We will be happy to enclose a card with your name or your own card if you wish. Let us make his Christmas a Merry one!

## Electrical Ignition Circuit

Q) "The ignition circuit on page 55 of your catalog appears to be unsafe. Would you please explain it?" J.P. - Miami, Fla.

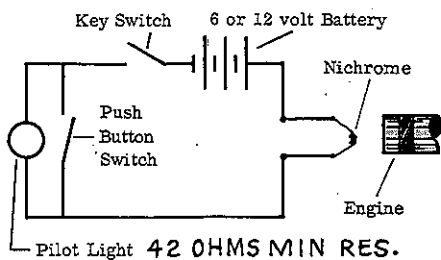

A) This circuit, same as on page 55, is actually quite safe and provides an important "continuity check". As shown in the above diagram, when the key switch alone is closed a circuit containing the Pilot Light, battery, and nichrome igniter is completed. Since these elements are in "series", a "break" anywhere in this circuit will prevent the pilot light from lighting, thus indicating an incomplete circuit. If however, this circuit is complete, the pilot light will light up.

The heat produced by the nichrome loop is directly related to the number of amperes of current (I) flowing through it. Since the pilot light has a very high resistance, the amperage in this "check" circuit is so low that the temperature of the nichrome will rise at most 3-4 degrees; not nearly enough to ignite an engine.

When the push button switch is closed, the current has a new path with very little resistance that it can follow. With constant voltage, a decrease in resistance results in an increase of current flow so that the nichrome heats rapidly to the 550 degree F required to ignite the propellant.

## Minimum Order Amount Requested

Because of increased costs of processing, packaging, and shipping your order, and because of higher postal rates coming next year, we are having a tough time holding prices down. You can help us hold the line by keeping your order amount to \$2.50 or more. Just to open, check, select, and package the smallest order costs over 65¢, and this does not include the cost of the merchandise or the postage. Actually, a \$2.00 order costs us about \$2.05 to fill and process. Many rocketeers place several \$1.00 orders about a week apart. Please try to combine all your orders into one. By your helping us out this way, we can keep prices down, give you better service, and we'll be around longer to supply your Model Rocketry needs. Thank you!!

## More Research & Development Award Winners Announced

Congratulations fellows! The R & D entries are looking better, and competition is getting tougher. Our R & D Department has just announced the following winners:

- 1) Phillip Billings - Age 17, Monroeville, Pa., Submitted working model and scale drawings of "SWIFT Pop Pod Boost-Glider".
- 2) H. D. Hastings - (over 21) Mount Vernon, N.Y. Submitted plans "Launcher Modification for Remote Control".
- 3) Steve Slesinger - Age 13, Springfield, Va. Submitted plans for "Inexpensive Theodolite Tracking System."
- 4) Lynn Bohsen - Age 14, Livingston, N. Jersey. Submitted plans for "NIMBUS Payload Rocket".

### HONORABLE MENTION

- 1) Mark Wheatley - Age 12, Bethesda, Md. Detailed plans for "Rear Ejection Parachute Recovery".
- 2) Michael Berkowitz - Age 14, East Meadow, N.Y. Good ideas for "Nose Cone Modification by Combination with Reduction Fittings".

### CROSSWORD PUZZLE ANSWER

|    |   |    |    |    |    |    |   |    |    |    |   |    |   |    |
|----|---|----|----|----|----|----|---|----|----|----|---|----|---|----|
| 1  | L | O  | X  | 3  | A  | P  | O | 5  | L  | 7  | S | O  | L | 11 |
| 2  | U | R  | A  | T  | 13 | R  | E | D  | S  | T  | O | N  | E | 15 |
| 14 | N | A  | A  | 16 | L  | I  | G | Y  | H  | S  | A | 17 |   |    |
|    | A | Y  | 18 | A  | W  | O  | L | 20 | B  | O  | R | E  | S |    |
| 22 | M | 23 | S  | I  | N  | 24 | P | A  | R  | A  | T | E  |   |    |
| 26 | C | A  | P  | E  | 27 |    |   |    |    |    | P | A  | D | S  |
| 29 | E | R  | R  | 30 | V  | E  | N | U  | S  | 32 | S | C  | A | R  |
| 34 | N | S  | 35 | C  | I  | A  |   | S  | 36 | U  | A | R  |   |    |
|    | T | 37 | N  | E  | P  | T  | U | N  | E  | 38 | N | L  |   |    |

## M. A. R. S.

Continued from page 4

have no trouble getting a relatively large membership. This makes large combined "club orders" of well over \$100 common, giving the club the advantage of large discounts with every order. This is a great source of capital for the club, giving them the opportunity to provide the members with an adequate technical library and financial backing for the projects conceived by the laboratory research committee.

By far the greatest advantage of having a rocket club centered around a high school, however, is the advantage of having the auditorium available to the club for monthly evening programs. These programs are presented by the club members on the basics of model rocketry. These informative meetings have put model rocketry in the spotlight at MacArthur, and they are doing much to create an active public interest in the club's activities.

# MODEL ROCKETS in the MOVIES

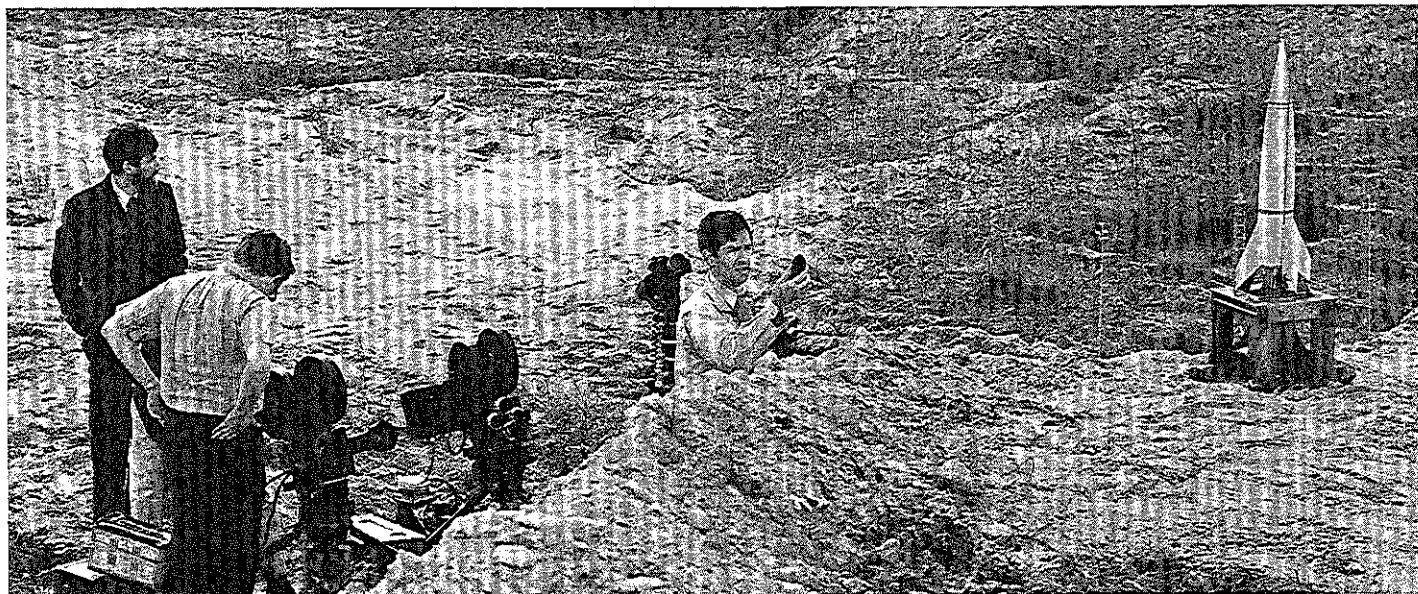

## Don Sahlin — TV & Movie Puppeteer "Turns on Rockets"

Don Sahlin, of New York City, manages to combine his hobby of model rocketry with his work. For years Don worked in Hollywood as a stop-motion animator. He worked on such movies as "TOM THUMB", "TIME MACHINE", "THE DINOSARUS" and the Cinerama film "WONDERFUL WORLD OF THE BROTHERS GRIMM". The studio Don worked for did special effects for rocket lift-offs and space shots and at that time he became interested in Model Rocketry.

He's been in the puppet business most of his life. He worked for years as assistant to Burr Tillstrom of "KUKLA, FRAN & OLLIE". Now working with THE MUPPETS in New York, Don's puppets have appeared on "THE ED SULLIVAN SHOW". His most famous creation is "ROWLF", the hound dog on last year's JIMMY DEAN SHOW and appearing most recently on "OUR PLACE" with the "Doodletown Pipers".

Don built the clustered rocket in the photos, for a quick launch sequence in a film produced by the Muppets called, "TIME PIECE". It won a Venice Film Festival Award and was nominated for an Academy Award. Power for this rocket is supplied by a cluster of six B 3-5's around a MINI-MAX 'E' type engine. Needless to say, it lifted off quite rapidly. The rocket itself is 30" tall and 4" in diameter. It has a hand turned and hollowed balsa body, and incorporates a piston-type parachute ejection system. It took several months to build.

Don's primary interest now is high speed photography of realistic launches using clustered engine power. Mr. Piester of Centuri recently visited with Don in New York and toured his "fantastic" model and puppet building shop at "THE MUPPETS".

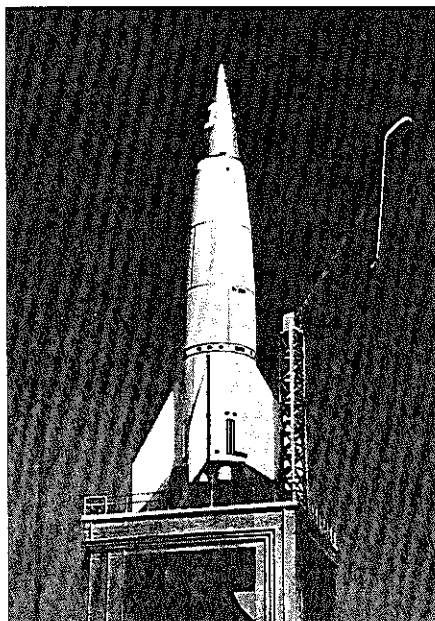
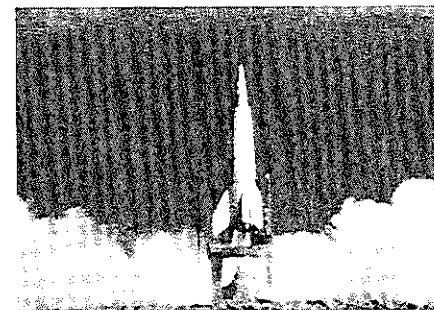
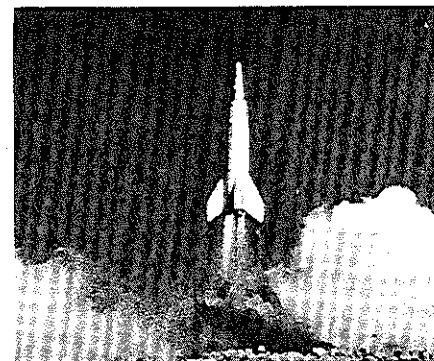
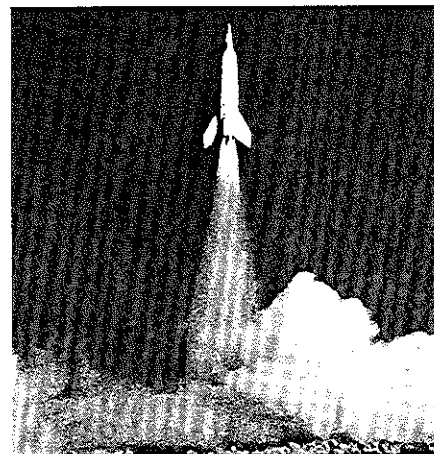

Real or a Model??

Lift-Off Sequence

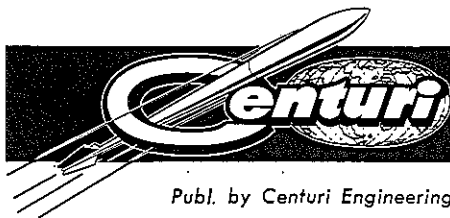

# TECHNICAL REPORT

Publ. by Centuri Engineering Co.

#TLR-51

© Copyright 1967

## "Ignition of Clustered Model Rocket Engines Using "Sure-Shot" Igniters"

The key to having a successful "clustered engine" flight is getting all three engines to ignite at the same time. For if they do not all ignite at the same time, the rocket will pitch off course to one side or the other.

Many systems have been developed for accomplishing simultaneous ignition of clustered engines. However, we have found the following system to be the most reliable.

### THE SURE-SHOT/PARALLEL WHIP METHOD

The heart of this system is Centuri's new "SURE-SHOT" Igniters, available in kit form in a package of 12 for 50¢ (Catalog No. IG-12). Each igniter consists of 3 parts. Assemble and install these igniters as shown below:

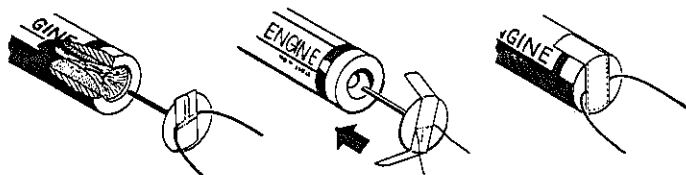

After you have installed an igniter in each of the three engines to be clustered, mount each engine securely in the rocket vehicle as outlined in Centuri's Engine Operating Instructions.

### WIRING UP THE CLUSTER

All three Igniters should be wired up in Parallel and connected to the firing circuit as shown below:

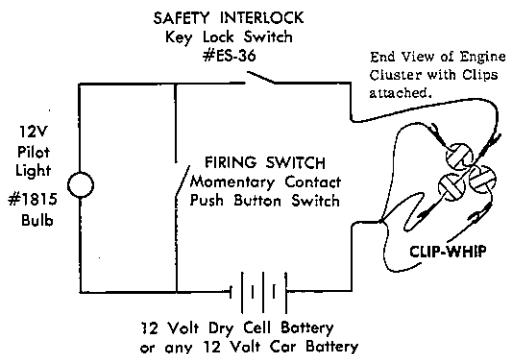

This particular circuit contains a continuity check which tells you (by the glowing Pilot Light) if the entire circuit is complete and all connections are good. If the pilot light fails to light up, this means that there is either a loose connection in the circuit or one of the micro-clips is not attached properly to the igniter wire.

The "Clip-Whip" shown in the circuit is simply three lead wires (about 7-8" long) branching off from one side of the main firing line, with a Micro-Clip fastened to the end of each branch wire. Its purpose is to evenly distribute current to one leg of each igniter installed in the cluster.

**PLEASE NOTE:** It is extremely important that all Micro-Clips be clamped firmly onto the Igniter nichrome wire as close up to the rocket engine as possible. Caution: Do not let the clips touch each other.

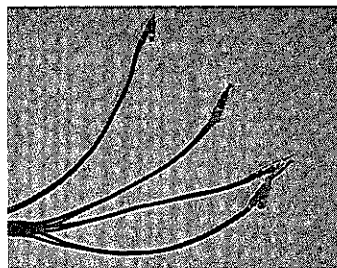

CLIP WHIP Close-up

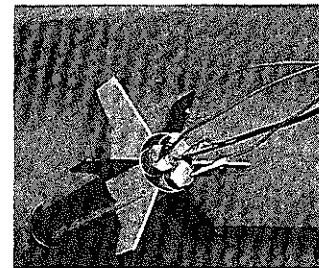

Centuri's DEFENDER with whip attached

To make a "Clip-Whip", solder a flat jawed Micro-Clip to one end of each of three 7-8" lead wires. Twist the opposite ends together and solder them to one end of the main firing line. A single Micro-Clip should be attached to the other side of the firing line wire.

**IMPORTANT:** Use only flat-jawed Micro-Clips, such as Centuri's EMC-34's. Do Not Use ordinary alligator clips as they will not properly "bite" the igniter wires.

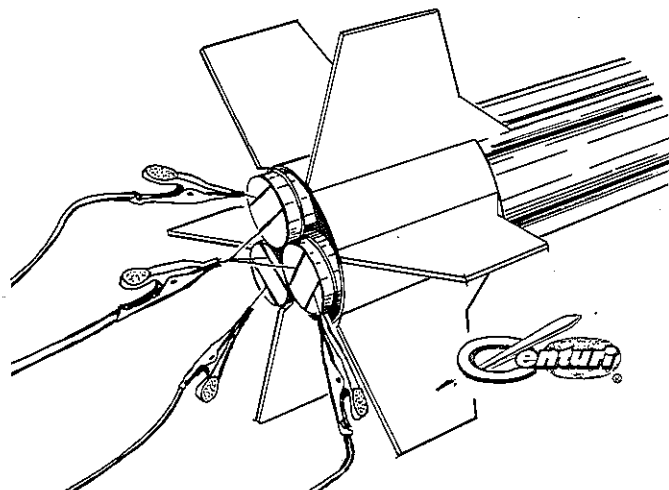

### POWER REQUIREMENTS

A minimum of 9-12 Volts of battery power is required to ignite all three engines at the same instant in time. Any of the following batteries are recommended for "Cluster Power".

#### 12 Volt Battery

- 12V Eveready #732 Lantern
- 12V Eveready #1463 Hot Shot
- 12V Marathon #926 or 904
- 12V Ray-O-Vac #904 or 922
- 12V Mallory M904
- 12V Bright Star #164 or #187
- 12V Burgess TW2 or S461
- 12V Burgess 4F6H or 2G8H
- Any 12 Volt Car Battery

#### Use 2 in Series

- 6V Eveready #731 Lantern
- 6V Eveready #520 Lantern
- 6V Eveready #1461 Hot Shot
- 6V Eveready #1462 Hot Shot
- 6V Eveready #706 Emerg.
- 6V Ray-O-Vac #641 or #918
- 6V Ray-O-Vac #902 or #903
- 6V Mallory #M904 or #M903
- 6V Burgess 4F4H or 4F5H