

PO BOX 1252, LEWISTON, MAINE 04240

FIRST CLASS

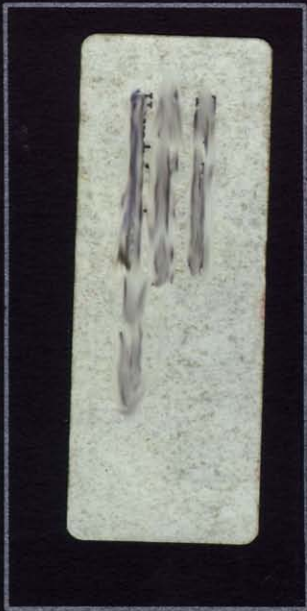

TO:



CNA SYSTEMS

CNA SYSTEMS

CATALOG 791

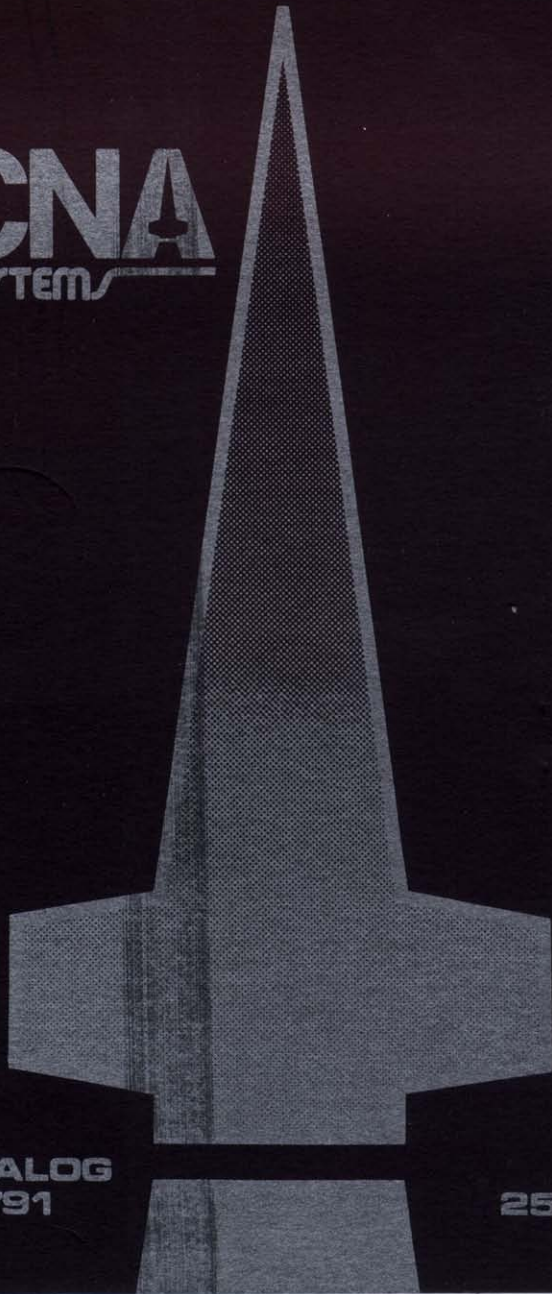

25c

PRODUCTS FROM THE INNOVATORS IN MODEL ROCKETRY

CNA

SYSTEM

TOMORROW'S TECHNOLOGY FOR TODAY'S ROCKETEER

10% DISCOUNT
COUPON

DEAR ROCKETEER,

AS A WAY TO INTRODUCE CNA'S
products, included is this 10%
Discount Coupon for your order.

"GYRO"

Bjth

CNA

SYSTEMS

PRICE LIST

<u>CATALOG NO.</u>	<u>PRICE</u>
TA-150	\$1.75
TA-135	5.45
NMX-4	1.25
NXS-1	1.25
DS2	12.95
DT2	12.95
MD-2B	29.95
MD-2BK	24.95
FL-1	3.25
TAO-2	3.95
TS-2	4.95
ACK-1	2.95
SVL-1	3.25
BNS-1	3.45



TEMPERATURE ALERT SYSTEM

CNA SYSTEMS, P.O. BOX 1252, LEWISTON, MAINE 04240

GREETINGS,

In this incredible age of electronics, the role of integrated circuit technology is constantly expanding. CNA Systems was created to bring this technology to the model rocketeer. We are proud to have pioneered the first portable, hand-held automatic digital launch system (the Midi-launcher), as well as the award winning electronic delayed staging system (the DS2).

Combined, we have twenty-one years of spacemodelling experience to guide us in new product design and development. Many of our product prototypes have been entered in regional and national R&D competitions with a-stounding success.

Our line of model rocketry supplies reflects this same philosophy of design and development as our electronic systems: to provide you, the model rocketeer, with new concepts and products that add realism and excitement to your model rocketry experience.

If you are looking for the new, the novel, and the unique in model rocketry equipment--look to CNA Systems, THE INNOVATORS in model rocketry.

"Get your rockets off!"

B. H. CELETTI
Rodger C. Fenton

THE BANSHEE

The BANSHEE is CNA's answer to a common recovery problem. How many times have you watched your model drift out of sight over a hill, into some trees or tall grass never to be seen again? With the BANSHEE installed in the nose cone of the model you can follow your rocket and locate it without seeing it land. Of course, getting it out of the tree one located is another problem.

The BANSHEE is a small powerful buzzer which emits a high decibel tone, easily heard within 75 feet of the rocket. Lightweight, about 9 grams with a single watch battery; it fits inside a plastic BT-20 nose cone. Great for windy days and small fields. Make your eagle scream!

Catalog no. BNS-1



TEMP-ALERT

PROTECT YOUR MODELS FROM CATO'S DUE TO TEMPERATURE CYCLING

- * EASY TO USE
- * CHANGES COLOR AT THE "CRITICAL TEMPERATURE"
- * INEXPENSIVE INSURANCE AGAINST CATO'S
- * NAR MESS FORM PROVIDED

Tests have shown that when a model rocket engine temperature cycles through 65° C (150° F), and is then fired, over 50% will show catastrophic failure.

Interior temperatures of a parked, car or closed metal range box have been known to reach 65° C. Engines stored in these places should be suspect.

The CNA TEMP-ALERT is a self-adhesive temperature sensor label calibrated to 65° C ± 1%, with a response time of one second. Upon reaching the critical temperature, the TEMP-ALERT turns from white to black.

For total protection, have one engine temp-alerted in each place of storage.

12 sensors.

Catalog no. TA-150



"OH - DID YOU MEAN
I SHOULDN'T HAVE
USED THE ONES WITH
THE BLACK LABELS?"

TEMP-ALARM

PREVENT ENGINES FROM TEMPERATURE CYCLING

- * SMALL SIZE
- * SOUNDS LOUD WARNING AT 57° C (135° F)
- * INSTALLS IN MINUTES -- NO SPECIAL TOOLS
- * USES TWO AA BATTERIES (not included)

To prevent your model rocket engines from temperature cycling, CNA Systems has developed the CNA TEMP-ALARM. The TEMP-ALARM is an electronic temperature sensor warning device. Installed in your range box or place of engine storage, the TEMP-ALARM uses no power until the temperature probe senses a temperature of 57° C (135° F). At that point, the TEMP-ALARM emits a loud raucous buzzing, thus warning of possible temperature cycling. Use with CNA TEMP-ALERT for total protection.

Dimensions: 8 cm x 6 cm x 3 cm

Catalog no. TA-135

Note to Midi-launcher owners: see Temp-alarm option, page 10.



"WILL YOU EXCUSE ME A MOMENT? I
HEAR MY ENGINES CALLING."

NOMEX® WADDING & SHROUD LINE

WHEN THE SPACE SHUTTLE SOARS, IT'LL BE WEARING WAY OUT FELT!

A highly engineered felt of heat-resistant, high temperature NOMEX fibers will cover nearly all of the 37 meter long, delta winged spacecraft.

NOMEX -- Dupont's incredible, heat resistant fiber is now available to the model rocketeer. CNA System's NOMEX Wadding is the first truly reusable wadding material for protecting parachutes and streamers. NOMEX Wadding is practically indestructible, allowing it to be used for flight after flight. It will probably outlast the rocket itself. CNA NOMEX Wadding is especially useful in demo birds, when fast, reliable prep-ping is needed.

Four protectors

Catalog no. NMX-4

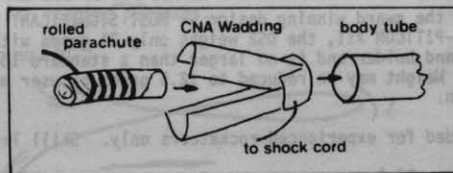

The perfect companion to NOMEX Wadding, NOMEX Shroud line is stronger yet lighter than ordinary shroud line. Its lack of stiffness plus its smooth finish reduces tangling and knotting problems inherent in ordinary line.

By using CNA NOMEX Shroud Line for your parachutes, burnthrough and wear is virtually eliminated. Teamed with CNA NOMEX Wadding heat damage to recovery devices can be almost eliminated to insure long life for your prize models plus reliable recovery on important contest flights.

40 meter spool

Catalog no. NXS-1

NOMEX is a registered trademark of the Dupont company.

DS2

DELAYED STAGING SYSTEM

- * TIME DELAY 0 - 11 SECONDS
- * LIGHTWEIGHT, SMALL SIZE
- * AWARD WINNING DESIGN
- * FULLY ASSEMBLED PC BOARD

The DS2 is a reliable electronic delay timer (up to 11 sec), for optimization of staging delay times or to accomplish staging of widely separated engines in scale models.

A LASCR senses flashbulb ignition of the lower stage and begins the timing sequence. At the preprogrammed delay time the upper stage is ignited via flashbulb ignition. Both stages use time delay engines to deploy their respective recovery systems. The LASCR may be used as a simple SCR for mechanical triggering.

Based on the award winning design -- MOST SIGNIFICANT NEW PRODUCT--PITTCON XII, the DS2 weighs only 21 grams with battery and holder and is no larger than a standard 18 mm engine. Weight may be reduced to 12.5 grams by user modification.

Recommended for experienced rocketeers only. Skill level 6.

Catalog no. DS-2

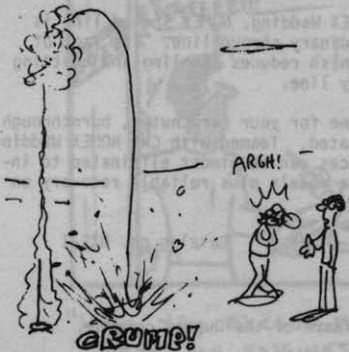

'DO IT RIGHT, I SAID.
'GET YOURSELF A DS2!'
BUT, NO - YOU HAD
TO BUILD YOUR OWN
STAGING SYSTEM....

DT2

DE-THERMALIZER TIMER

- * TIME DELAY 0 - 330 SECONDS
- * PROGRAMMABLE
- * IC CIRCUITRY
- * FULLY ASSEMBLED PC BOARD

The DT2 is a special version of the IC design of the DS2, modified for glider or parachute dethermalization. The DT2 can be automatically triggered like the DS2 or started manually with the integral power switch, since split second timing is not required. The size and weight are similar to the DS2. The DT2, like the DS2, comes with an LED for setting the time delay.

Recommended for experienced rocketeers only. Skill level 6.

NOTE: The DT2 is not suitable for the short delay times needed for staging purposes.

Catalog no. DT-2



"YOU WAIT -MY FUSE WILL WORK
AS WELL AS YOUR CNA DT2...
ANY SECOND NOW... ANY SECOND NOW..."

NOW ONLY 12.5g!

MIDI-LAUNCHER 2

FEATURES:

- 9 TO 0 COUNTDOWN
- FLASHBULB IGNITION
- LED DISPLAY
- IC CIRCUITRY
- POWER/RESET KEY
- START/HOLD SWITCH

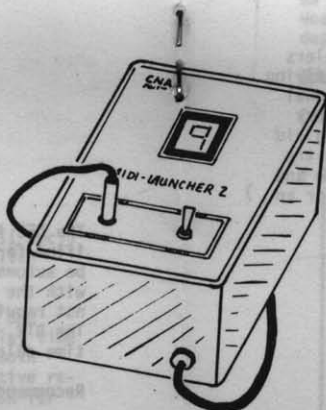

NEW FEATURES:

- 60% LARGER DISPLAY
- LOW POWER CMOS CIRCUITRY
- CONTINUITY CHECK
- BEEPING COUNTDOWN
- AUDIBLE SAFETY KEY
- SINGLE 9V BATTERY SUPPLY
- TEMP-ALARM OPTION

The Midi-launcher is CNA Systems revolutionary new concept in launch systems. Featuring advanced CMOS circuitry for ultra low power requirements and long battery life, the Midi-launcher is the ultimate in personal ground support equipment.

The MIDI is a hand-held automatic digital launch controller with self-contained battery supply for total portability. It can be used with any type launcher and is designed for flash-bulb ignition. Instructions are included for simple modification for any type of ignitor.

Insertion of the safety key turns on the MIDI, at the same time resetting automatically to nine. A buzzer indicating that the MIDI is armed remains on as long as the safety key is inserted. Continuity is indicated by the decimal point of the LED display. The countdown is commenced by pushing the control switch to START. The buzzer turns on and off with each count, indicating to all spectators that a countdown is in progress. The countdown may be stopped at any time by returning the switch to the HOLD position. Reset is accomplished by removal and reinsertion of the safety key. Upon reaching zero, ignition is automatic and your rocket will soar into the proverbial wild blue. The buzzer will continue to sound until the safety key is removed.

The Midi-launcher is available in two versions; fully assembled and kit form. There is also an accessory to add a TEMP-ALARM function to the Midi-launcher. This option is featured on page 10.

- CAT. NO. MD-2B MIDI with buzzer, fully assembled
- MD-2BK MIDI with buzzer, kit

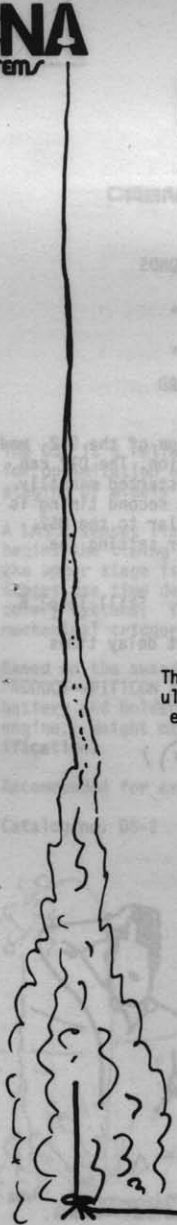

THE FLASHER

The first product specially created for static spacemodelers. Add a little excitement to your models, both static and flying with the CNA FLASHER. Small integrated circuit flashes dual light emitting diodes (LEDs). Runs off any 1.5 volt battery from N-cells to hearing aid batteries; tests with hearing aid batteries have shown 9 days continuous flashing. (Don't try D-cells, unless you are very patient.) Mini-power switch and battery holder included. Additional LEDs may be added for an impressive display.

Catalog no. FL-1



TEMP-ALARM SENSOR

This option allows the buzzer circuitry of the MIDI-2B to be utilized in a TEMP-ALARM function. The temperature probe, when plugged into the power/reset jack, will turn on the MIDI-2B when it senses the sub-critical temperature of 57° C. Turning on a MIDI-2B will activate the audible safety key, causing a loud buzzing.

The TEMP-ALARM sensor may be permanently installed in a range box, thus increasing the MIDI-2B's usefulness during the periods between launches.

No special tools required for construction.

Catalog no. TAO-2

TEAM T-SHIRT

Be an unofficial member of the CNA Systems' factory team! Wear the official competition colors, rocket, and GYRO* design.

Specify size when ordering. Men's size S, M, L, XL.

Catalog no. TS-2

* GYRO -- Get Your Rockets Off!



"I THOUGHT THE T-SHIRT WAS
THEIR BEST PRODUCT"

AUDIBLE CONTINUITY KIT

TIRED OF LOOKING AT DIM CONTINUITY LIGHTS?

GIVE YOUR LAUNCH SYSTEM A VOICE.

This kit will provide audible, beeping continuity indication on any commercial or custom built launch system. The beeper circuitry draws only 12 ma, and is thus below the Bruceton No-fire levels for all ignitors, including electric matches and flash-bulbs. Installation is simple. Full instructions provided.

Catalog no. ACK-1

MAXI-LAUNCHER

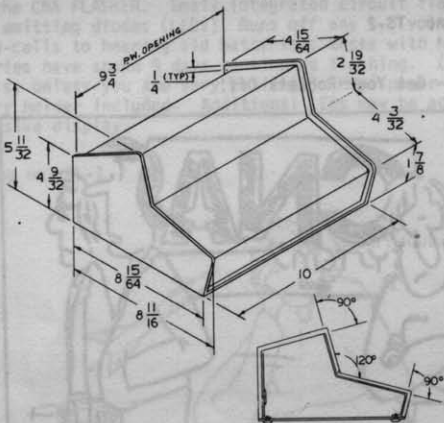

FEATURES:

- CUSTOM DESIGNED AND BUILT**
- COMPUTER STYLE CONSOLE**
- LED DISPLAY**
- STOPWATCH FUNCTIONS**
- MULTIPLE LAUNCH CAPABILITY**
- AUDIBLE CONTINUITY CHECK**
- SELF-CONTAINED RACK**
- MANUAL AUTO COUNTDOWN**

The Maxi-launcher is the ultimate in multiple launch systems. It is custom designed to your specifications. The computer styled control console is equipped with these basic functions: automatic countdown and ignition of up to sixteen rockets, manual fire, start/hold/reset function, individual pad selector switches, safety key, and audible continuity check. The LED display shows countdown and pads selected. The rack is also custom designed for as many positions needed and the configuration desired. The rack also contains all launch support equipment: launch rods, clips, blast deflectors, and collapsible legs for ease of portability to and from the launch site. The Maxi-launcher is powered by a 12 volt automobile battery.

The rest is up to you.

Starting price \$495. Final price will depend upon options.

Serious inquiries only.



"WOW - DID YOU SEE THAT LAUNCH?! I CAN REALLY BUILD 'EM, HUH, GUYS?... GUYS?"

SURVIVAL KIT

A sampling of CNA products to help you survive the cruel world of prangs and catos. Contains everything you need to protect your rockets against the above mentioned evils and shock your friends.

Contains:

- 1 NOMEX Wadding parachute protector
- 3 TEMP-ALERT sensors
- 1 NOMEX Shroud line kit (enough for 1 'chute)
- 8 Tape discs
- 1 CNA G*Y*R*O sticker in fluorescent green
- 1 Official CNA note pad
- 1 KEVLAR cut resistant work pad

KEVLAR is a duPont fiber which is stronger than steel and is very lightweight. It is used in many applications such as tire cords and bullet proof vests. The CNA Kevlar pad is a foldable pad which resists cuts from your hobby knife -- works great for cutting balsa when a cutting board is not available. The whole kit comes in a resealable zip-lock pouch.

Catalog no. SVL-1

ONE OF THOSE DAYS



FROM THE WORKBENCH

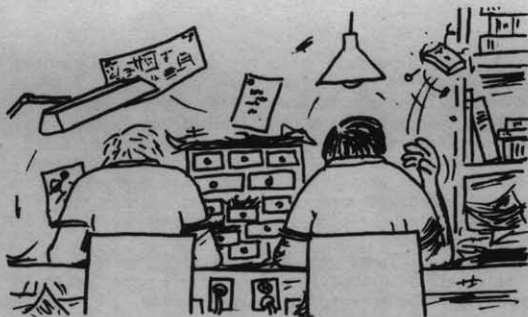

The future holds big things in store for the CNA. We can't give away all of our surprises for '79, but look for an expanded new catalog coming in June. Having twice as many pages or more, it will feature many new products, photos and graphics.

Some of the new products include:

THE BEACON -- a brilliant strobe flash unit to be carried in the payload section of a model. Operates on 3volts (2 N-cells) and provides spectacular night flights.

THE RACK -- An inexpensive multi-position launch system for clubs and schools. Also available with a MIDI option for those of you who like the realism of an automatic countdown.

Also in the works is the T3 Tracker. A version of Trip Barber's award winning tracking head, complete with tripod to provide a complete ready to use system.

Let us know what you think of the CNA and our products. If you have any ideas for products which you would like to see, drop us a line and tell us about them.

P.S. Many thanks to Dave Brooks for his special touches and humorous(?) cartoons. Also to Hugh Blair for technical assistance in printing.

ORDERING

Use order form provided. Keep top copy for your records and send remaining copies. Use ball point pen. A new order form will be provided with each order. Be sure to include the postage and handling charges in the total as well as insurance if desired. Full payment must be included with order. Please use check or money order. No C.O.D.'s, cash or stamps, please. Any overpayment will be refunded with order. We cannot be responsible for orders, coins, or currency lost in the mail.

Orders will be shipped via UPS, if street address is provided. All others will be shipped via parcel post. No orders will be accepted without ZIP code.

Insurance: We recommend that orders which must be shipped parcel post have insurance. If coverage is desired, add \$.50 to order. UPS orders have insurance included.

Maine residents add 5% sales tax.

POSTAGE and HANDLING CHARGES:

<u>Amount of order</u>	<u>Add</u>
under \$3.00	\$.25
\$3.01 to \$10.00	.50
\$10.01 to \$20.00	.75
\$20.01 to \$40.00	1.00
over \$40.00	4% of total

Orders outside of continental U.S. write for details.

Dealer inquiries welcome.

NOTICE OF RESPONSIBILITY

Our model rocketry products are intended for experimental and educational use. You are cautioned to exercise utmost care in the use of our products. We do not accept any responsibility for accidents. User shall determine the suitability of the product for his intended use, and assume all risk and liability in connection therewith.

Electronic products are warranted against defects in parts and workmanship for 100 days after shipment. Responsibility will be to repair or replace unit at our discretion.

Prices and information in this catalog supercede all others.

ORDER FORM

NAME

DATE

ADDRESS

CITY

STATE

ZIP

QUAN. CAT. NO.

PRICE

TOTAL

QUAN.	CAT. NO.	PRICE	TOTAL

CNA
SYSTEMS

P.O. BOX 1252
LEWISTON, ME
04240

SUBTOTAL

SALES TAX 5%
(MAINE RES.)

POST. & HAND.

TOTAL ORDER