

MODEL

ROCKET

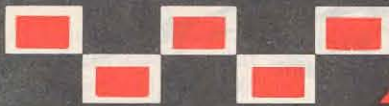

NEWS

VOLUME 9, NO. 3
NOVEMBER 1969

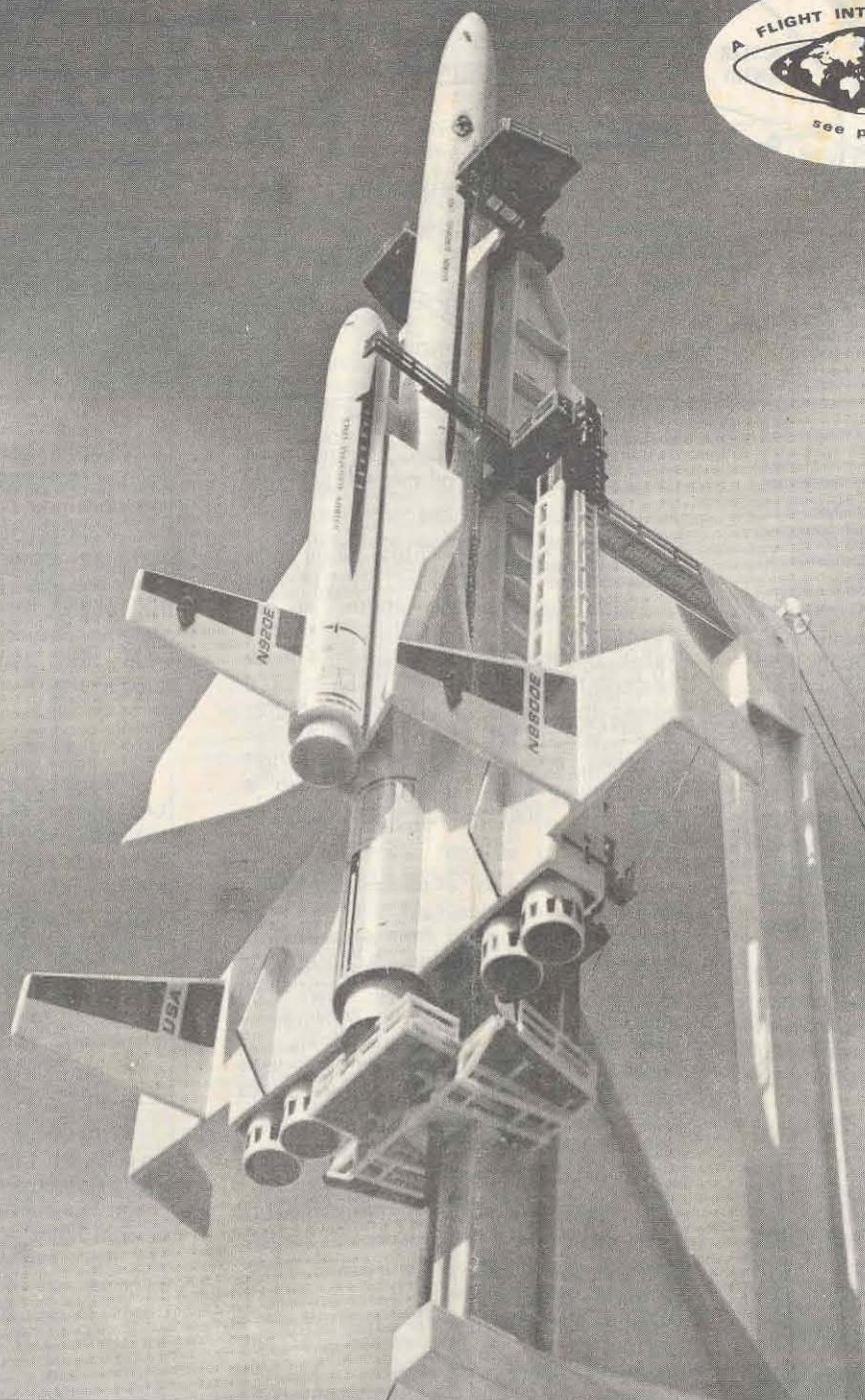

Orbital Transport Concept

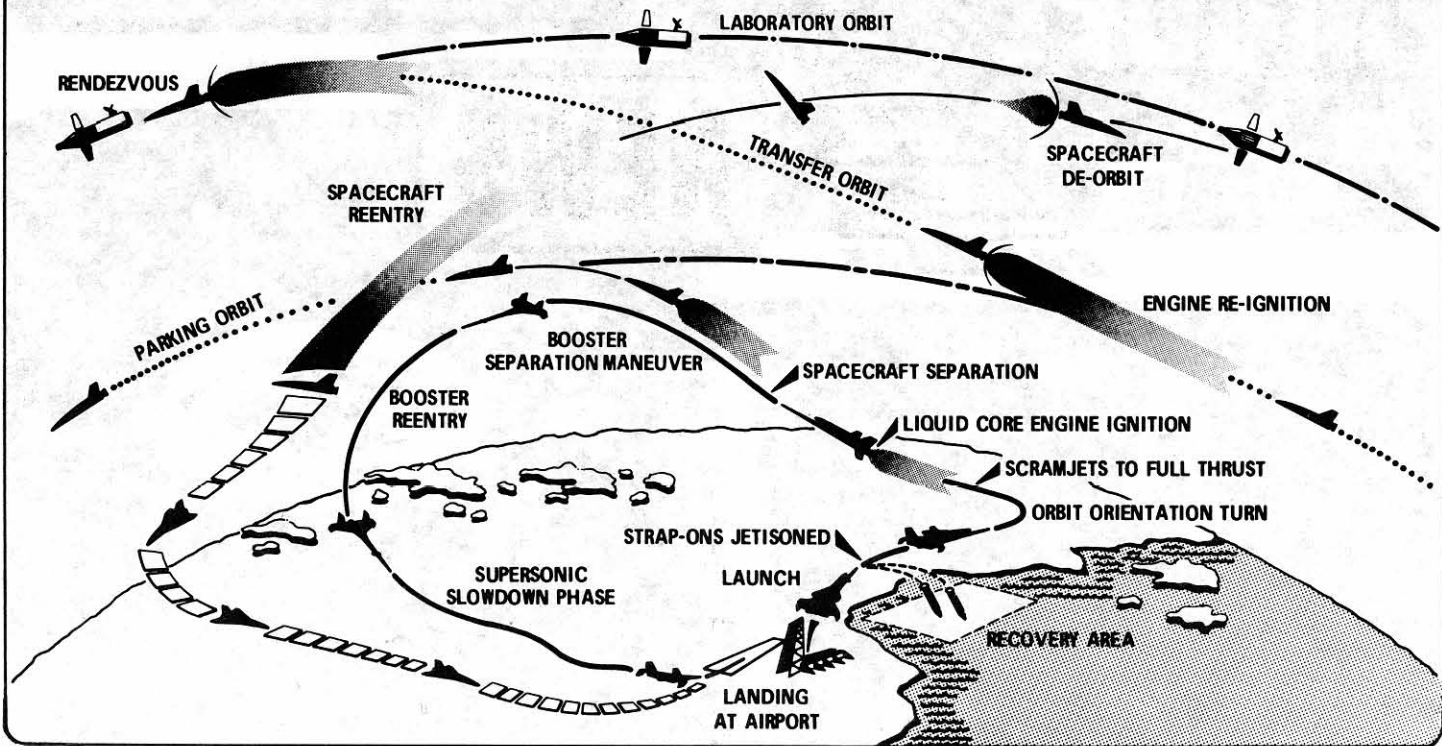

Some day soon you may ride an elevator to the passenger compartment hatch of a liquid-fueled second stage/reentry vehicle. You and 11 other passengers in pressure suits are strapped to acceleration couches while, immediately in front of you, the three man crew runs through final preflight preparations. A small television screen shows similar preparations in the 2-man cockpit of the first stage booster vehicle.

As the countdown proceeds the hatch is closed; the elevator structure rolls away, leaving the rocket supported by the launch tower. At "zero" the two solid propellant strap-on engines roar to life. In a fraction of a second thrust has reached lift-off level and the transport begins to rise from the tower. It begins its pitch-over maneuver almost immediately.

By the time an altitude of 3000 feet is reached you are traveling almost horizontally. In less time than it takes a subsonic jet airliner to become airborne you have broken the sound barrier. The dual mode subsonic/supersonic combustion ramjets begin to produce significant thrust and the solid propellant strap-ons are jettisoned. Your flight

enters its cruise phase, heading east to get in position for the orbital run.

Two hundred miles from the launch site your booster pilot begins a wide turn to the south; as he levels off you are in line with the orbit of the Weather Bureau's new observation laboratory. You cruise along this path for almost a minute. Then you're hit in the back as the engines are brought to full thrust and the nose is pulled up into a gradually increasing climb angle.

It only takes a minute to reach Mach 5.5. You can feel the shock as the ramjets change from subsonic to supersonic combustion. Acceleration jumps to 2.5 g's, then begins to decrease gradually as you pass 100,000 feet altitude. When the liquid-fuel core engine comes to life at 120,000 feet, acceleration again increases reaching a peak of 3 g's before you reach 140,000 feet.

Near 160,000 feet the scramjets are shut down; the transport continues to accelerate under rocket power to its staging velocity of 10,000 miles per hour. The engine cuts off; you feel a jolt as booster and second stage separate. As you coast on up the booster maneuvers down and to the side.

Twenty seconds after separation the second stage engine ignites and you continue on to orbit. Meanwhile the booster is continuing up in a ballistic trajectory. It will coast over the top and plunge back into the atmosphere, its leading edges glowing cherry red as it slows in a wide turn and heads back to the launch site.

The second stage engine thrusts for a total of about three minutes, boosting you into a parking orbit. After one revolution the engine fires again briefly and you enter a transfer orbit, rising to the altitude of the laboratory. Several short correction bursts from the engine are felt, then several more from the attitude thrusters, before you actually dock at the lab.

While arriving passengers are moved into the laboratory and departing passengers take their places, the cargo container is removed from its compartment and secured to the side of the laboratory. Within fifteen minutes of docking the spacecraft casts loose and begins to maneuver for reentry. It will return to the same base from which it was launched. After servicing it will be joined to a booster vehicle for another flight.

Man's efforts in space today are much like a bather dipping his toe into the water to check the temperature; he must decide whether he is going to stay out or plunge in. If the decision to plunge in is made, the first requirement will be a low cost method of placing large payloads in orbit.

Although the cost of putting a pound of payload in orbit has dropped from around \$1,000,000 in 1958 to near \$1,000 in 1969, another reduction of similar proportion is necessary before space travel can become a common activity. The Orbital Transport represents one approach to this cost reduction goal.

Two concepts appear to be the keys to low-cost orbital flight--the reusable vehicle and air breathing (jet) propulsion. By recovering, refurbishing and reflying a vehicle basic manufacturing costs can be spread over many flights. The use of oxygen from the air offers a considerable reduction in propellant costs when compared with liquid oxygen or some exotic oxidizer.

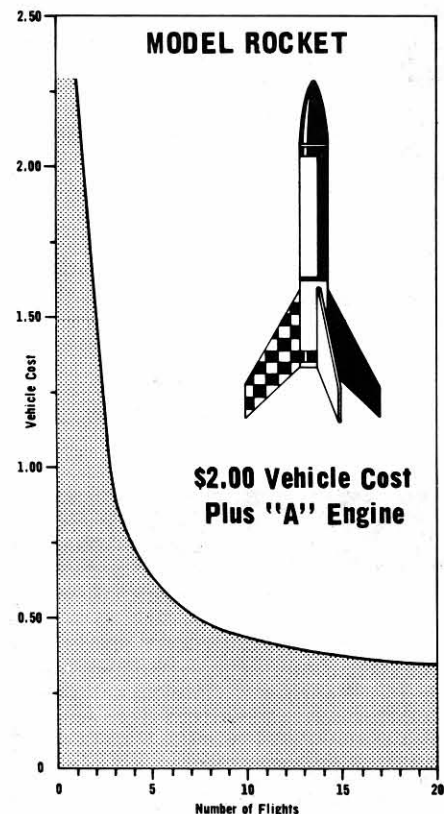

Model rocketry offers a good example of the cost reduction realized when vehicles are reused. The diagram shows the average

cost per flight of an Astron Alpha (including paint, glue, wadding, etc.) when A8-3 engines are used. Notice that although the average cost drops most over the first few flights, it takes many flights to reach a "rock-bottom" figure which is a little more than the cost of engines.

The "pre-flight" cost of a reusable space vehicle would undergo a similar (but not so dramatic) reduction. The costs of recovery and refurbishment are much greater in proportion. Early proposals called for reuse of more conventional vehicles by deploying parachutes on lower stages after reentry, letting the stage land in the ocean and returning it to a remanufacturing center by barge. Recovery costs in this case become quite high.

For smaller, unmanned vehicles, this method may be feasible. However, it would be preferable to have the booster return directly to the point at which it will be serviced and relaunched. The obvious way of doing this is to fit the booster with wings and let it fly back.

Once the decision to use wings has been reached, the addition of airbreathing (jet) propulsion becomes a logical next step. Vehicle costs are roughly proportional to take off weights. Jet engine booster systems offer reductions ranging from one tenth to one half the weight of rocket systems of comparable payload capacity.

Lower initial weight means that less propellant is needed, cutting the cost of each launch. At Mach 12 (roughly half of orbital velocity) the supersonic combustion ramjet can provide 4 times as much thrust per pound of propellant used, compared to the best rocket engine. This increase in efficiency results in a further reduction in propellant costs.

Finally, once a rocket is launched, it must continue on up to orbit or abort. An airbreathing vehicle can go into a holding pattern after takeoff, allowing great flexibility in scheduling and orbital altitudes and angles. Rendezvous missions can be accomplished much more easily since the vehicle can cruise to the ideal location before beginning the actual orbital run.

The big problem facing airbreathers is that no one type of jet engine will operate efficiently over the velocity range of a booster stage. Turbojets cannot be used at velocities much over Mach 4.

Conventional ramjets must be accelerated to several hundred miles per hour before they begin to produce thrust; they in turn cannot be used at velocities much over Mach 6. The supersonic combustion ramjet (scramjet) won't function below Mach 3; it will, in theory anyway, work at velocities in excess of Mach 25 (orbital velocity). As a result an airbreathing vehicle requires a combination of propulsion systems to allow it to function efficiently.

ECONOMIC JUSTIFICATION

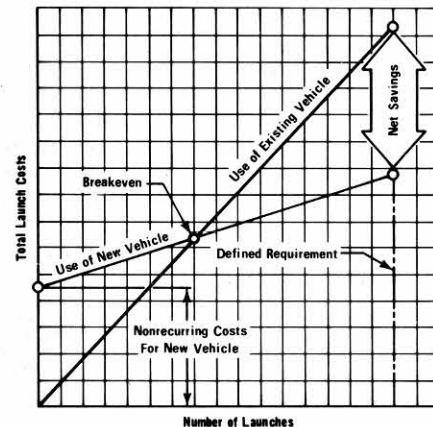

Technology, time and money available will govern the choice of systems for a practical orbital transport. Some groups favor horizontal takeoff systems, others support vertical takeoff. Scramjets are not practical today--but 5 years' research might perfect them. Structural materials for hypersonic velocities at lower altitudes are not yet available--but rocket engines for use at high altitudes are.

Much also depends on traffic requirements. When traffic volume is low, it's better to use one launch site with specialized ground support equipment. When volume increases to the right level it is best to provide several flight origin sites located for the convenience of the passenger. When this level is reached, vehicles which can use conventional airfields with a minimum of special ground support equipment will be necessary. Often the same airfield which handles SST civilian traffic will be ideal for orbital traffic.

The Astron Orbital Transport looks to the nearer future when traffic still originates from one or two points in the United States. Its design is based on technology which is well within reach in the next 15 years. When vehicles like this are flying, we will truly be in the space age.

NOTES FROM THE BOSS

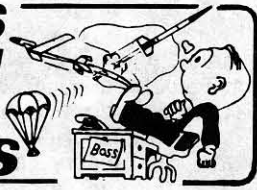

thing I've done for the last ten years, day and night, has been to 'live, breathe, eat, and sleep' rockets. I like my work, I like rocketeers and I wasn't about to give them up. But on the other hand, I also knew that a merger with the right company could have some advantages. For instance, to continue improving our service to rocketeers we need to greatly expand our facilities, and that takes money, which is difficult to find in today's economy.

products and they share a real concern for what a company can do for its customers. I was impressed because, among other things, Damon is in the field of educational devices for science study, space electronics, and the field of medical services and equipment, where their efforts are directed toward providing worthwhile services for mankind.

Some of you may have already heard the good news - the news concerning the joining of Estes Industries with Damon Engineering. But for those of you who haven't, let me tell you about this merger.

As you probably know, Estes got started way back in 1958, the year after the first earth satellite was placed in orbit. The operation began with practically no money, and only the dream that out there was a world of young scientists who would be interested in a safe form of rocketry if it were available.

We worked hard, and when the company was a little less than one year old, "Mabel I" went into production, making the world's first safety engineered - mass produced model rocket engines. It wasn't long until our first kit - the Astron Scout - was marketed through a small classified ad in Popular Mechanics. Then our business began to grow. We moved away from home (Denver) and took up a new residence in Penrose, Colorado. The company continued to develop as we listened to the friendly advice of America's rocketeers, learned what products and services they wanted, and then made them available.

We searched continuously to find ways to keep prices low so you could afford to be a model rocketeer, and at the same time designed only reliable high quality rockets that you and your friends would be proud to own and fly.

Then, a couple of years ago, Estes started getting large enough to be noticed. Big companies began calling to see if we were interested in selling or merging with them. Among those that approached us were businesses involved in activities ranging all the way from professional rocket manufacturing to outfits that made hobby products, bowling balls, and toys. At first, we weren't interested. My thinking was that every-

After a while, I began to visualize a solution. If I could merge Estes Industries with the right kind of company I would still be able to continue my work in model rocketry, and at the same time have the advantage of the larger company's finances and assistance.

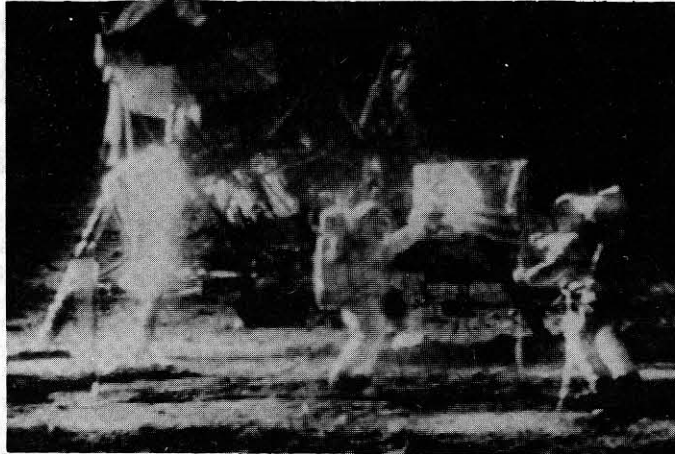

When Man first walked on the moon we saw and heard him because of the use of sophisticated electronic devices such as the voltage controlled crystal oscillators supplied by Damon. Used both in the LEM and the Command Modules, the specialized equipment was made in the Damon Electronics Lab in Boston.

Then one day near the end of August, a phone call came in from Arthur Vash, Vice-President of Damon, and head of their Educational Division. "We've been reading about you, Vern, and we like the way you do things. How about my coming out from Boston to see you so we can discuss the possibility of merging Estes with Damon?"

As Art and I sat and talked, I began to see that this was the opportunity for which I had been looking. Damon Engineering was considerably larger than Estes, deeply involved in science and education, well financed, a public company listed on the American Stock Exchange, and, most important, they think as we do on vital things like the need for good, worthwhile

With both of us thinking alike and enjoying the kind of work we do, the final question remained. If we merged, could I keep on working at model rocketry, and if so, in what capacity? "Of course you would, Vern!", was the answer. "You're the guy who knows about model rocketry, not us! We would want you to continue as President and General Manager of the Estes Subsidiary of Damon. Nothing will change - you'll still live in Penrose and work with rocketeers the same way you do now."

That cinched it! On September 27 the merger took place. Estes Industries is now a wholly owned subsidiary of Damon Engineering, Inc., 115 Fourth Avenue, Needham Heights, Massachusetts 02194. I'm still in the model rocket business and the same Estes crew is still hard at work here at the Model Rocket Capital of the World. But with the joining of our two companies the future looks even brighter for our meeting of the ever expanding needs of America's model rocketeers.

Vern

Model Rocket News

© ESTES INDUSTRIES 1969

The MODEL ROCKET NEWS is published by Estes Industries, Inc., Penrose, Colorado. This publication is written for America's model rocketeers to promote safe youth rocketry, distribute current technical information and make model rocketry more enjoyable and educational. Current issues of the MRN are distributed free of charge to all active Estes customers.

Vernon Estes-----Publisher
William Simon-----Editor
Gene Street-----Chief Illustrator

THE

IDEA BOX



FIN ALIGNMENT GUIDE

Eric Cornish of North Canton, Ohio, submits this.

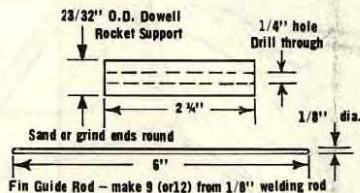
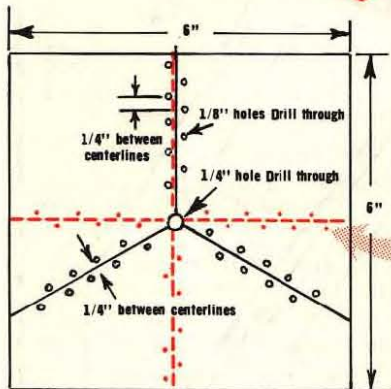

NOTE: BASE MAY BE SET UP FOR BOTH 3 AND 4 FINS BY DRILLING ADDITIONAL HOLES AT POINTS SHOWN.

Use a 1/4" by 8" dowel as a central support. Tape around dowel at the right height to support the rocket body in correct relationship to the fins.

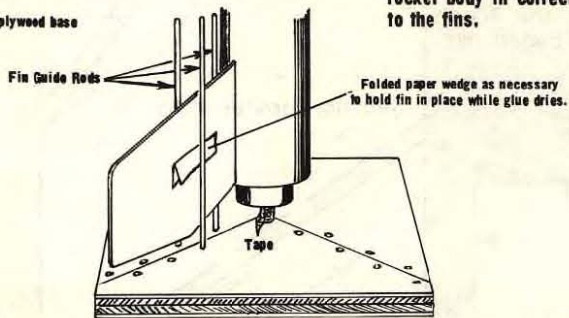

STRONG ENGINE MOUNT

Developed by Randy Gubar of Charlotte, N. C., who says this mount will withstand many series II engine powered liftoffs.

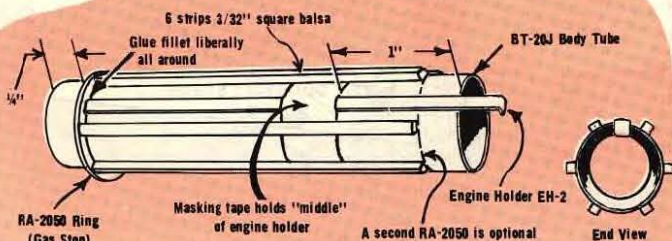

DYMO TAPE MAKES QUICK TRIM MATERIAL

From Denver, Colo., W. L. Schmelzel suggests dymo tape for striping body tubes and labeling the bird with the owner's name, address and phone number. The tape comes in 1/4" and 3/8" widths, and several colors. It can be trimmed with scissors to a variety of shapes--tapers, tear drops, thin strips, etc.

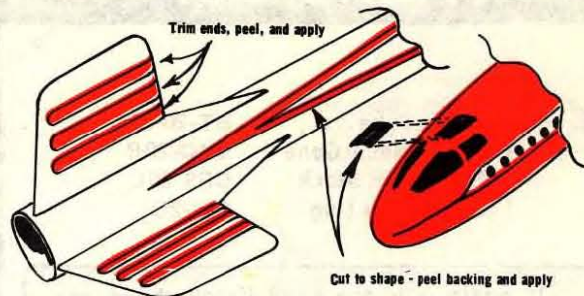

CLUB EMBLEMS

Ron Schweikert of Boulder, Colo., sends this way to make colorful club emblems in smaller numbers. (Better check with Mom first, or buy a new "T"-shirt especially for it, however.)

Draw emblem on T-shirt with ordinary crayon. Take your time and get plenty of each color worked into material.



Set iron for "cotton" and while waiting for it to get up to temperature spread the T-shirt and put a sheet of newspaper under the emblem, and one over the emblem.

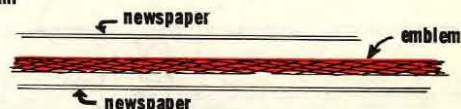

Holding the top sheet in place, iron over the area of the emblem (or if it is small enough, place iron over emblem) for 30 seconds. Lift top sheet of newspaper and allow shirt to cool before moving.

HAND WASHING IS RECOMMENDED!

PAINT CORNER



Pamela Keopsl of Marengo, Wisc., suggests dot detail may be applied by pencil point dipped into the small amount of paint found in the bottle cap. Just wear a point down to the dot size you want--then dip 'n dab....

Terry Schmaier of Saline, Mich., uses the plastic bag from the kit, and masking tape to protect the first color when applying the second color trim.

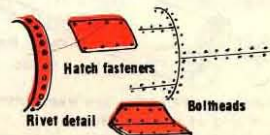

Estes Industries Rocket Plan No. 65

SKY HIGH 3 Stage Rocket

APRIL '69

DESIGN OF THE MONTH WINNER

by Dale Olesberg Coeur D'Alene, Idaho

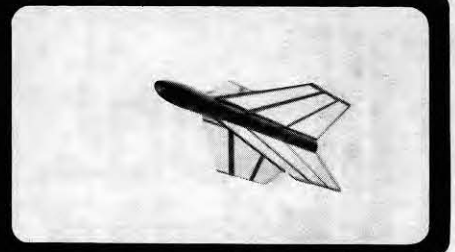

PUBLISHED AS A SERVICE TO ITS CUSTOMERS BY ESTES INDUSTRIES, INC., BOX 227, PENROSE, CO. 81240

© ESTES INDUSTRIES, INC. 1969

PARTS LIST

- | | |
|-------------------|---------|
| 3 Body Tube | BT-20-J |
| 1 Balsa Nose Cone | BNC-20B |
| 3 Balsa Fin Stock | BFS-20L |
| 1 Launching Lug | LL-2B |

In addition to the parts listed above, you will also need white glue, masking tape, scissors, a model knife or razor blade, sandpaper, carbon paper, a piece of heavy paper, a brush and paint or dope.

Mark the three body tubes for 4 fins each

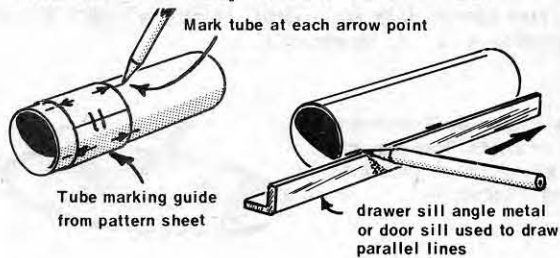

Glue the nose cone into one of the body tubes.

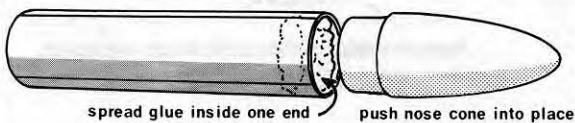

Glue the fins to the body tube for each stage.

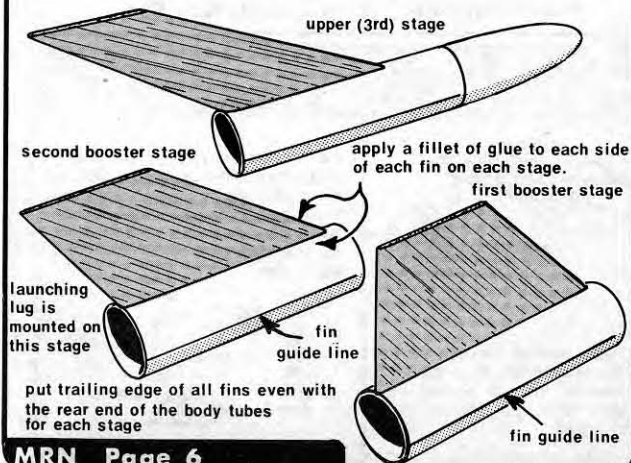

FULL SIZE FIN PATTERNS

Do part of the work necessary for a good paint job before gluing the fins on the model. When all fins have been cut from the sheet balsa stock, sand the leading, tip and trailing edges round. Sand the edges that glue to the body tube-flat.

Trace these patterns onto heavy paper and cut them out. Lay out four parts from each pattern, matching the grain direction of the balsa with that shown on each pattern.

For additional details, refer to the Technical section of your current Estes catalog.

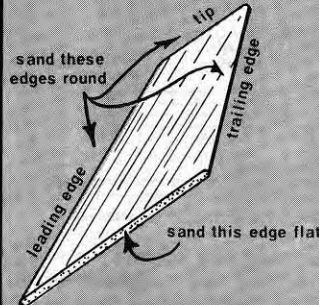

Sand the sides of each fin smooth to the touch with extra-fine sandpaper.

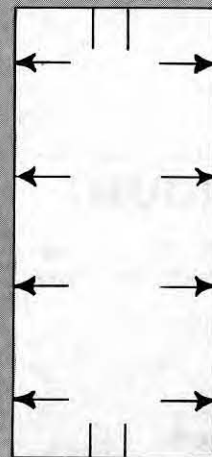
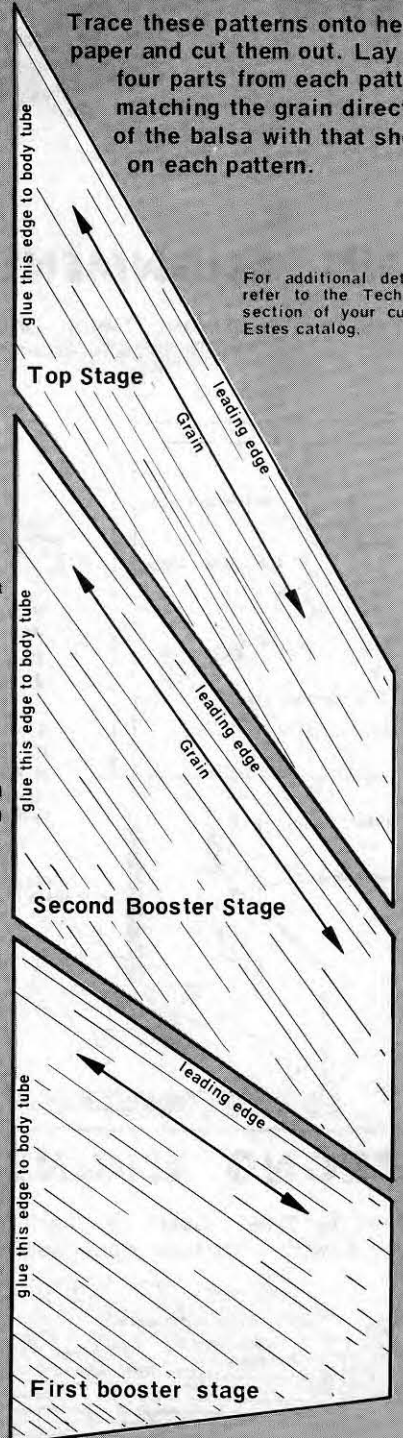

Fin Marking Guide

Trace guide onto typing paper; cut out and wrap around each body tube. Mark the tube at each arrow point, then extend a line through each pair of marks for the length of the tube. Repeat for other two tubes.

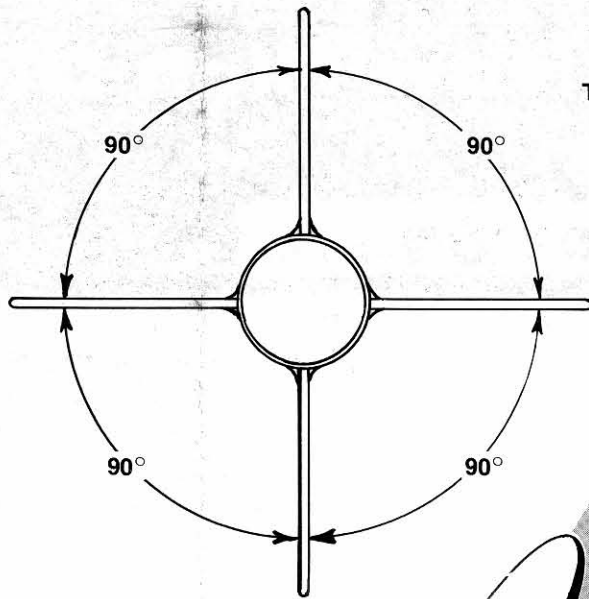
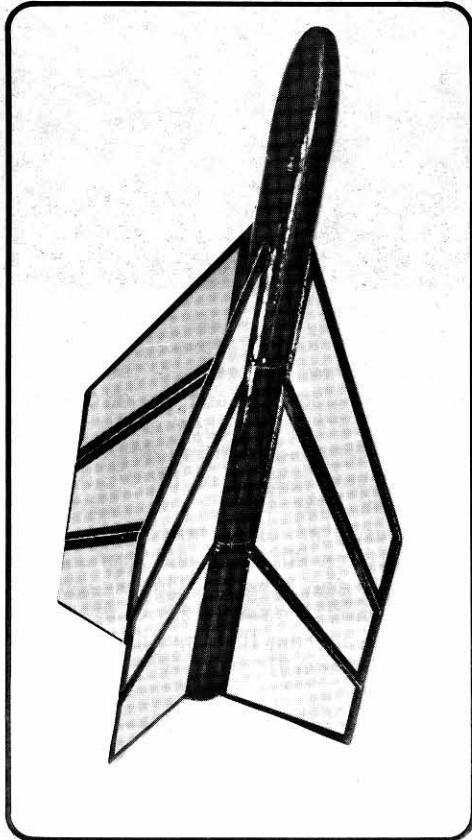

REAR VIEW
Typical of all three stages

For additional details, refer to the Technical section of your current Estes catalog.

FLYING

Since the boosters use tumble recovery and the upper stage has feather-weight recovery, special attention need be paid only to preparation of the engines for stage ignition and for fit in their respective stages.

PAINTING

Since "out-of-sight" flights are easily possible with this rocket, we suggest that you paint your bird with extra high visibility flourescent paints or at least with colors which are not otherwise found in your flying area.

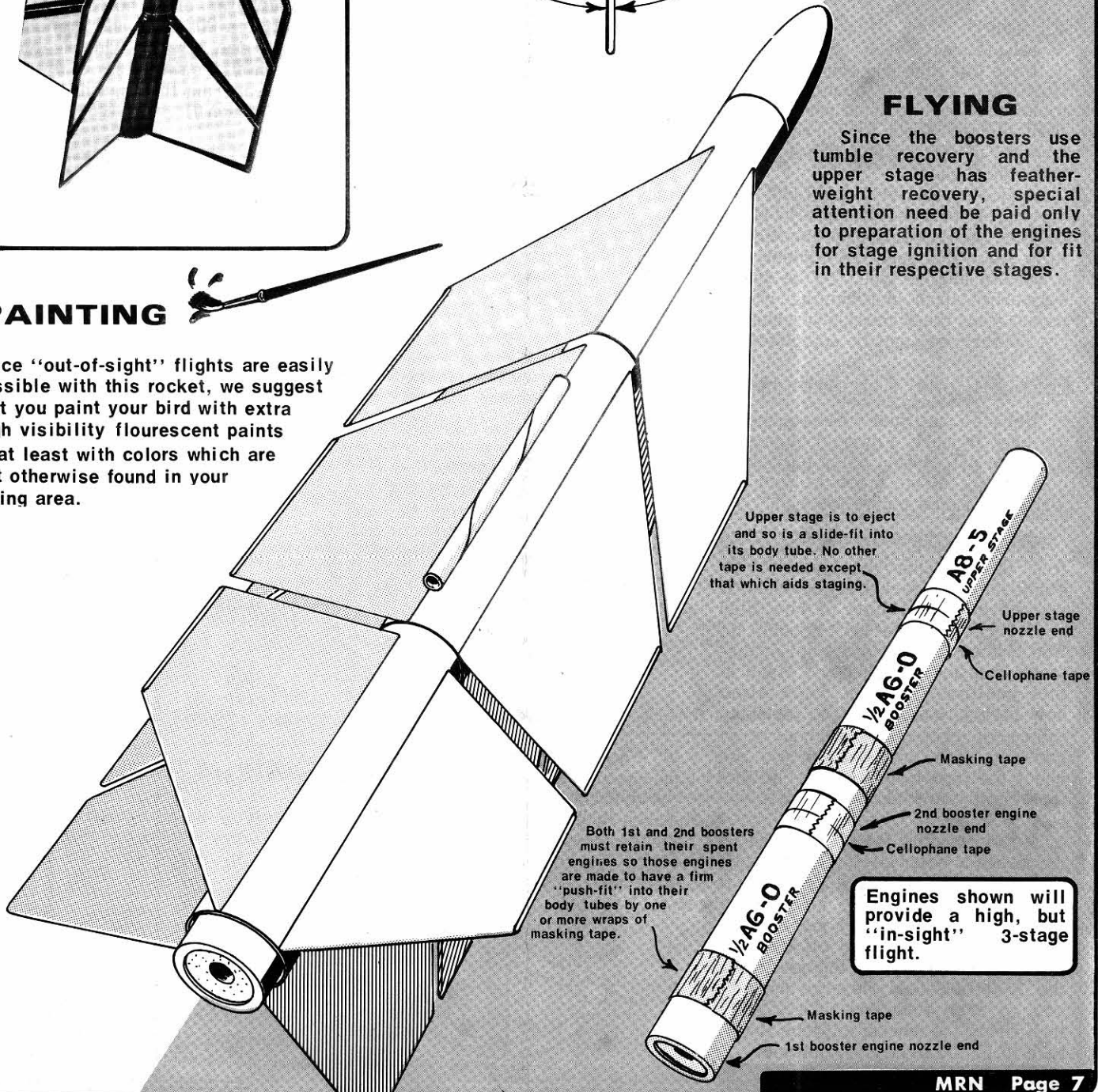

Engines shown will provide a high, but "in-sight" 3-stage flight.



How High Did It Go??

Another **ACTION** Article

by **ROBERT L. CANNON**



"My rocket went higher than your rocket!"

"Did not!"

"Did too!"

"Did not!"

"Did!"

Does this dialogue sound familiar? How often have you heard two *other* rocketeers arguing about whose model went higher? Sheer lungpower is not enough to determine whose rocket went the highest.

One of the easiest ways to judge rockets to find which is the "best" is to see which goes the highest with a certain engine type. To be really scientific about determining whose rocket went the highest, even careful "watching" may not be adequate.

Easy Altitude Calculations

Reliable altitude measurements are easy to make. For most purposes, a simple calculation using only three numbers is all it takes to find the altitude a model rocket reached.

First, measure to find how far from the launcher you are going to stand when the rocket is launched. If you have a good idea of how high your rocket should go, measure to find a place the same amount of distance from the launcher and stand at this position. When in doubt about how high a model will go, checking tables of predicted performance or guessing from past experience are about the best methods of predicting the height your rocket will reach.

Measuring this **BASELINE** can be done with a meter stick (slightly over a yard—39.37 inches), a yardstick if you can't get a meter stick, or a metric tape. If you can't get a better measuring device, pace off the distance. To use pacing for measuring the baseline, first measure how far you go each time you take a step, then figure the number of steps it will take to go the necessary distance.

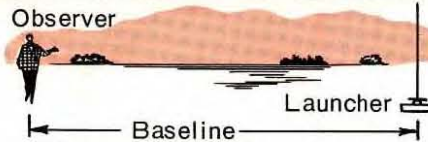

The second number you need is the **ANGULAR DISTANCE** the rocket travels from launch to apogee (highest point of flight). This is measured in degrees of angle.

The angular distance is determined by measuring the angle between the rocket's position on the launch pad (right at the tip of the nose cone) and the highest point (apogee) reached by the rocket.

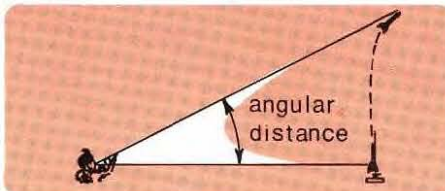

The measuring device used to find this angular distance can be a homemade "sextant", or may be the reliable Altiscope.

Homemade altitude-measuring device

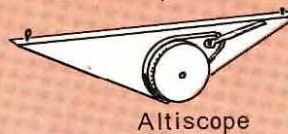
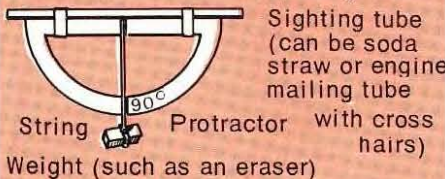

When using the homemade altitude measuring device, angular distance is found by subtracting the reading taken (angle marked) of the rocket at apogee from 90° .

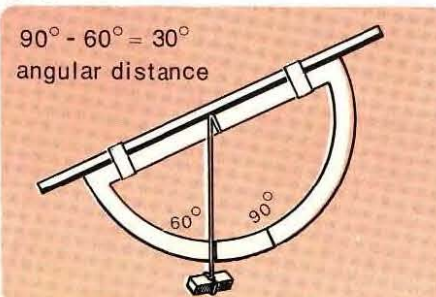

An Altiscope may be easily and quickly adjusted to correct for a difference between the elevation of the observer and the elevation of the launch pad. When using a homemade altitude-measuring device, a sighting must be made on the tip of the rocket on the launch pad and then the angular error noted (difference between 90° mark and the angle marked by the string). This is an error for which you will have to allow when measuring the angular height reached by each flight.

Example

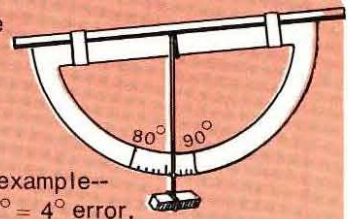

In this example--
 $90^\circ - 86^\circ = 4^\circ$ error,
therefore subtract four degrees from angular distances measured for each flight.

Once the angular distance moved by the rocket is known, simply consult a trigonometry table to find the **TANGENT** of that angle. (A copy of the tangent table is mounted on the Altiscope.)

TABLE OF TANGENTS

Angle	Tan.	Angle	Tan.	Angle	Tan.
1°	.02	28°	.53	54°	1.38
2	.03	29	.55	55	1.43
3	.05	30	.58	56	1.48
4	.07	31	.60	57	1.54
5	.09	32	.62	58	1.60
6	.11	33	.65	59	1.66
7	.12	34	.67	60	1.73
8	.14	35	.70	61	1.80
9	.16	36	.73	62	1.88
10	.18	37	.75	63	1.96
11	.19	38	.78	64	2.05
12	.21	39	.81	65	2.14
13	.23	40	.84	66	2.25
14	.25	41	.87	67	2.36
15	.27	42	.90	68	2.48
16	.29	43	.93	69	2.61
17	.31	44	.97	70	2.75
18	.32	45	1.00	71	2.90
19	.34	46	1.04	72	3.08
20	.36	47	1.07	73	3.27
21	.38	48	1.11	74	3.49
22	.40	49	1.15	75	3.73
23	.42	50	1.19	76	4.01
24	.45	51	1.23	77	4.33
25	.47	52	1.28	78	4.70
26	.49	53	1.33	79	5.14
27	.51			80	5.67

The final step to determine the altitude reached is to multiply this value by the length of the baseline. The product is the height reached by the rocket.

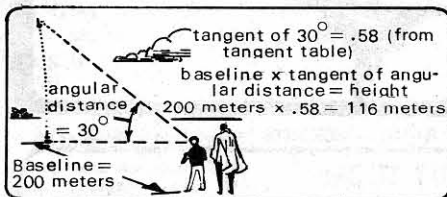

Now, calculate the height reached by this rocket.

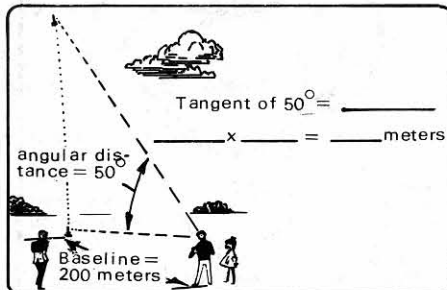

The rocket rose 238 meters

Now let's determine the height reached by another rocket. The information given is similar to the data given to the data reduction crew at a model rocket contest.

Baseline = 250 meters
 Angular distance = 70°
 Altitude reached = _____ meters*

* 687.5 meters

If your altitude for this flight was correct, you can skip the next two problems if you wish.

If your calculated altitude was not accurate, recheck your calculations to find and correct your error. Once you are able to correctly find the altitude, find the correct altitudes for the next two problems to be sure you know how to calculate altitudes.

Baseline = 100 meters
 Angular distance = 53°
 Altitude reached = _____ meters*

* 133.0 meters

Baseline = 500 meters
 Angular distance = 20°
 Altitude reached = _____ meters*

* 180.0 meters

Explanation of Tangents

You may have begun to wonder, "What is this 'tangent' that we've been using?" A tangent is a ratio (a numerical relationship). When working with a right triangle (a triangle with one "right" or 90° angle), the tangent is the ratio between the length of the *opposite* side and the length of the *adjacent* or nearest side.

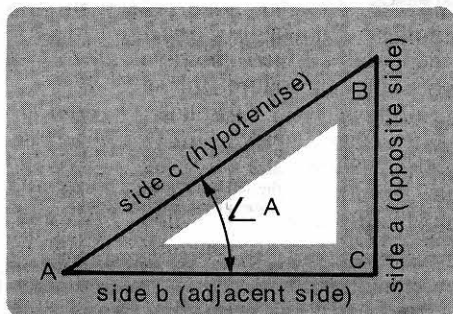

The tangent of angle A is the ratio of the length of opposite *side a* to the length of the nearest *side b*. The longest side of a right triangle is always called the *hypotenuse*. As an equation, the tangent of angle A is written:

$$\angle A = \frac{\text{opposite side}}{\text{adjacent side}}$$

Notice how this triangle resembles the situation when you are tracking a rocket. The rocket is launched from C and reaches apogee at B. The length of *side b* is measured and angle A is measured. To find the length of *side a* (the height reached by the rocket), we just multiply the length of *side b* (baseline) times the tangent of $\angle A$ (ratio of length of *side a* to length of *side b*).

To get a better idea of how this works, consider this situation: A flagpole casts a shadow 10 meters long. The angle the shadow and the tip of the flagpole make with the ground is measured and is found to be 45° . What is the height of the flagpole.

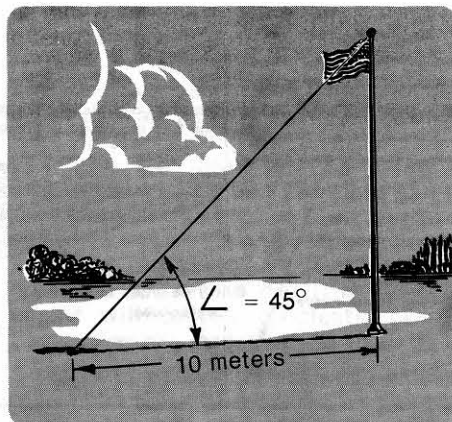

The flagpole in the picture appears to be about as long as its shadow. Checking the tangent table, the tangent of 45° is 1.00. Multiplying 10 meters times 1.00 gives a product of 10.0 meters, so our estimate turns out to have been accurate. A quick examination of the table shows that *rockets reaching angular distances of under 45° do not go as high as the baseline is long, but those going over 45° reach altitudes greater than the baseline's length.*

Two points to remember -

1. Rockets flown on windy days will usually not go straight up and hence will not go as high as they could have gone.
2. To minimize errors in altitude measurements for rockets going into the wind ("weathercocking"), station the tracker at right angles to the wind flow.

View looking down on launch area

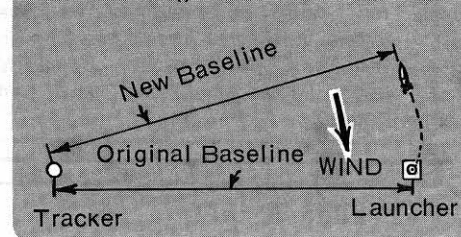

The rocket moves into the wind, causing a slight increase in the length of the baseline. This introduces a small error. The greater this "weathercocking", the greater the error. However, calculations are still based on the original measured baseline, so the altitude measurements computed will actually be a little low. Since every rocket launched from the launch pad will have approximately the same problem with the wind, reasonably accurate comparisons can be made between altitudes reached by different flights.

If the tracker were stationed either upwind of the launcher (into the wind) or downwind of the launcher (away from the wind), the amount of change in length of baseline caused by weathercocking would be fairly great as compared to the change in baseline for a tracking station at right angles to the wind.

For more information on altitude tracking, refer to Estes Technical Report TR-3, *Altitude Tracking*.

SCOTT - B

JUNE '69

DESIGN OF THE MONTH WINNER

by David M. Olsen Platteville, Wisc.

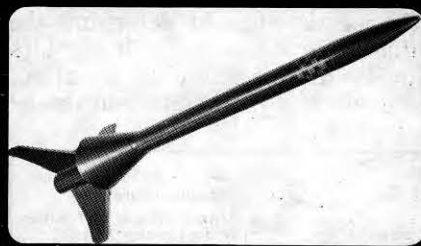

PUBLISHED AS A SERVICE TO ITS CUSTOMERS BY ESTES INDUSTRIES, INC., BOX 227, PENROSE, CO. 81240 ESTES INDUSTRIES 1969

PARTS LIST

1	Nose Cone	BNC-20N
1	Body Tube	BT-20B
1	Body Tube	BT-20G
3	Body Tube	BT-20M
2	Engine Block	EB-20A
1	Sheet Balsa Stock	BFS-30
1	Centering Ring	RA-2050
1	Shock Cord	SC-1
1	Screw Eye	SE-1
1	8" Parachute Kit	PK-8
1	Launching Lug	LL-2B
2	Nose Cone Weights	NCW-1

In addition to the parts above you will need scissors, white glue, a model knife (or razor blade), masking tape, paint brush and paint or dope. Also postcard and carbon paper.

1 MEASURE, MARK AND CUT TUBES

Install Engine Blocks

Draw all location marks and guide lines on all tubes as instructed for each below.

Install both engine blocks as shown. Mark an old engine 1/2" from one end--hold it by the end closest to the mark and use to position upper stage engine block.

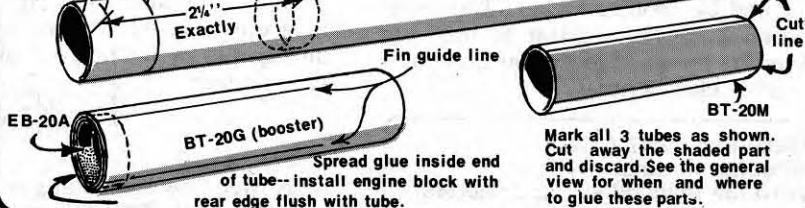
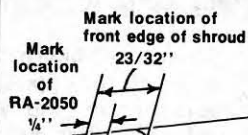

Spread glue inside body tube and locate an engine block as shown.

Lay guide on a flat surface. Place tube over proper part of guide and mark as instructed.

Mark all 3 tubes as shown. Cut away the shaded part and discard. See the general view for when and where to glue these parts.

PATTERNS 'N' INFO

2

STABLIZER SHROUD PATTERN

Trace onto heavy paper or postcard material, cut out, form and glue. See general view for location and fitting.

Trace onto card stock

FIN PATTERN (3 req'd.)

Grain
Leading edge

Glue this edge to booster

Pattern layout on Balsa fin stock

Shroud forming is easier when you pre-form the shroud--hold a pencil or dowel firmly against the shroud material...

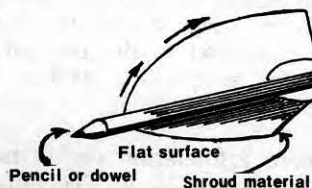

...gently, but firmly, pull the shroud up and across the pencil, forming a shallow, uniform curve in the shroud. Repeating will deepen the radius of the curve.

A great amount of finishing preparation can be done before the fins are glued in place...

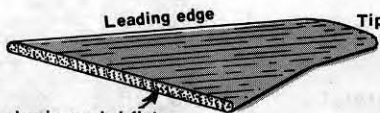

This edge is sanded flat--it will be glued to the booster tube.

Leading, tip and trailing edges are sanded round. Sand both sides of each fin flat and give each fin an additional sanding with extra fine sandpaper or sanding material.

3 INSTALL FINS

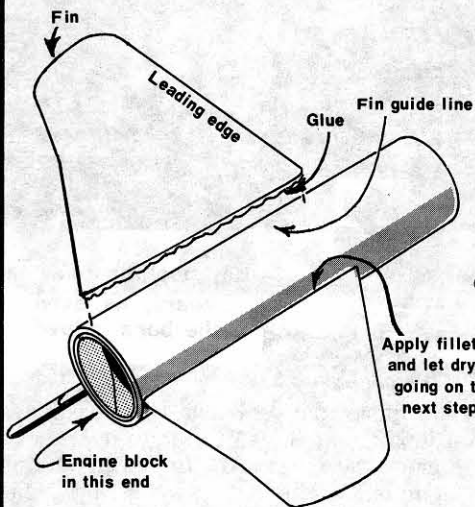

Apply fillet of glue and let dry before going on to the next step.

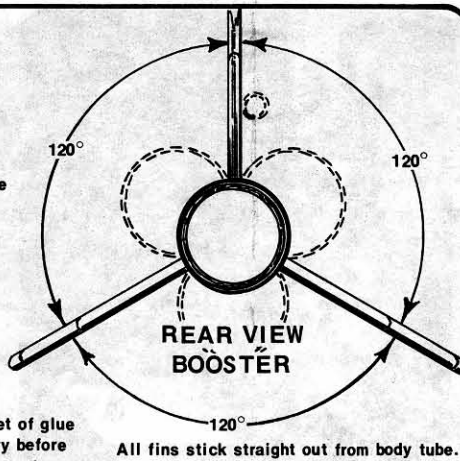

All fins stick straight out from body tube.

4 INSTALLING FAIRING TUBE PARTS and launching lug

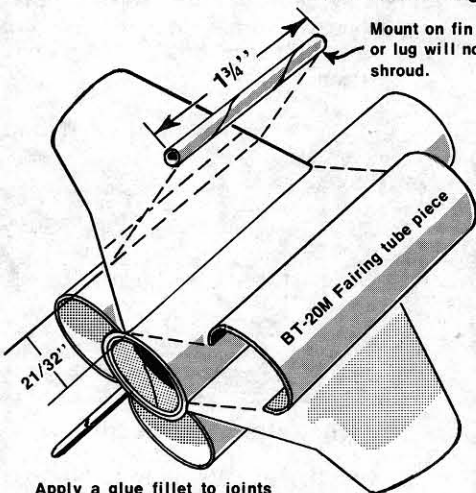

Mount on fin not lower than 2 1/32" or lug will not clear upper stage shroud.

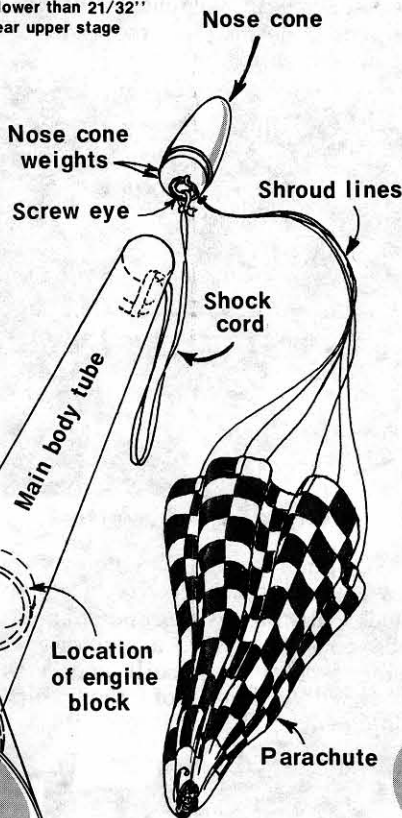

Apply a glue fillet to joints as shown then set a tube piece in place. Repeat with the remaining 2 pieces, holding each in place until the glue has set.

Location of centering ring

Location of engine block

GENERAL VIEW

5 INSTALL SHROUD

Apply a line of glue around the body tube and place the RA-2050 exactly 1/4" in from the rear end of the tube--all the way around.

Coat inside of shroud with high heat aluminum--treat outside with coat of sealer.

Stabilizing cone

6 INSTALL THE SHOCK CORD

Install as directed in the technical section of your current catalog.

Apply glue around tube where you marked in step 1. Slide the shroud into place from the front end.

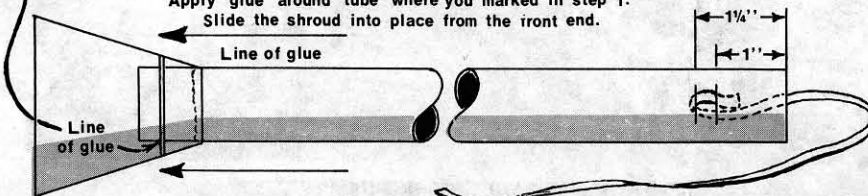

MORE WINNERS! DESIGN OF THE MONTH CONTEST

Design of the Month contest winners for the months of April through September, '69 were recently announced by the Estes Industries judging staff.

The First Place \$50 award for April went to Dale Olesberg of Coeur D'Alene, Idaho for his 3-stage *Sky High* rocket. Top honors for May were given to Justin Otten of Grand Rapids, Mich. for a combined control panel-launcher unit. The winner of the June contest was Dave Olsen of Platteville, Wisc. with the two-stage *Scott B* model. July honors were garnered by Bob Houston of Fremont, Nebr. with his *SST Scorpion*. The August award was given to Ivan Joe Sandman, Lewistown, Mont. and his *Blue Lightning*. September went to Douglas W. Johnson of Randolph A.F.B., Texas for the twin-engined *Antenoid - 3*.

All Estes rocketeers are encouraged to enter the Design of the Month Contest. Plans for rockets, launchers, instruments, etc., may be entered. A new contest begins on the first of each month so entries compete only with other entries received in that month.

Any plan or design received at Estes Industries that is not specifically addressed to some other contest or department is automatically entered in the Design of the Month Contest. For complete details, see the contest information in your current Estes catalog.

7 FLYING

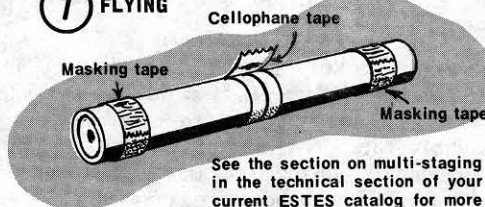

See the section on multi-staging in the technical section of your current ESTES catalog for more details. The upper stage engine must fit tightly into place so the recovery system will work correctly. The booster engine must fit tightly into its stage to prevent the section from being left behind at lift-off.

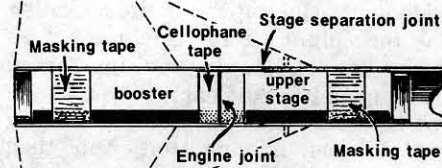



KIT PACKING

“BFS-20” “Check” “BT-20AE” “Check” “PK-8A” “Check”..... “Everything’s here, let’s get these Beta kits packaged.”

This is part of the work of Kit Packing, the largest department at Estes. Packaging the kits and engines which go out to keep America’s model rocketeers launching keeps this department busy 24 hours a day.



Kits and engines...go out...24 hours a day.

Every rocket kit a rocketeer assembles and flies started out as a series of pieces or parts on an assembly table. After double checking to make sure all of the correct parts are there, they are carefully loaded into plastic bags, one kit at a time. A “header” is applied to the open end of the bag and the whole unit is sealed with heat.

Kit Packing is the home of the “Moose.” Making the weirdest noise in the plant, this machine glues paper caps on engine mailing tubes. Each model rocket engine from Estes is inserted into a tube containing instructions and igniters and then sealed by the Moose.



...“header” is applied...and the whole unit is heat sealed.

Other kits packed in this department include the Electro-launch, the Altiscope, the Tilt-A-Pad and the many other support items necessary for successful launches. Keeping up with the demand on these items is quite a task in itself.



Every kit starts as pieces...

Originally, kit packing was done as a spare time activity by shipping and mail processing personnel. As the company grew, a separate shipping facility was built and packing became a part of the shipping department.



Kit packing over the years, as even the boss helped.

Time passed, and the combined department moved to larger quarters — and then moved to even larger quarters. Finally, a year ago, the demand for model rocket kits reached such proportions that it was necessary to split into two separate departments. Since then, Kit Packing has grown larger than its “parent” department.

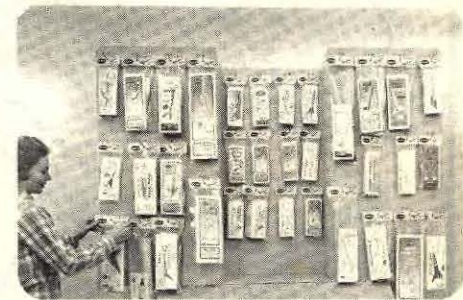

Kits, kits and more kits...

Even though it’s grown, however, the Kit Packing department’s goals are still the same: to provide you with the kits you want, to make sure every kit you get is complete and to make sure each part is of the highest quality. Each and every department is important at Estes; Kit Packing is a vital link in the chain of service essential to safe and enjoyable Model Rocketry.



...even larger quarters