





**ESTES INDUSTRIES**  
 1295 H STREET  
 PENROSE, CO 81240 USA



# Sunbird

#1936

**SHOCK  
CORD  
MOUNT**

SEC. 3

SEC. 2

SEC. 1

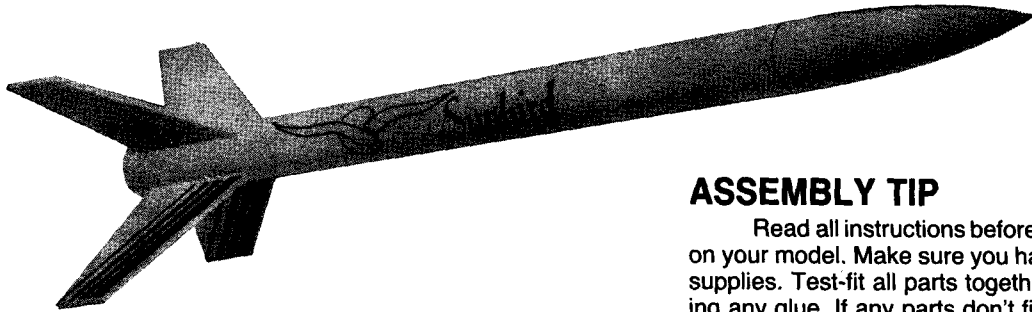

## ASSEMBLY TIP

Read all instructions before beginning work on your model. Make sure you have all parts and supplies. Test-fit all parts together before applying any glue. If any parts don't fit properly, sand as required for precision assembly.

## PARTS AND SUPPLIES

Locate the parts shown below and lay them out on the table in front of you. In addition to the parts included in the kit you will also need:

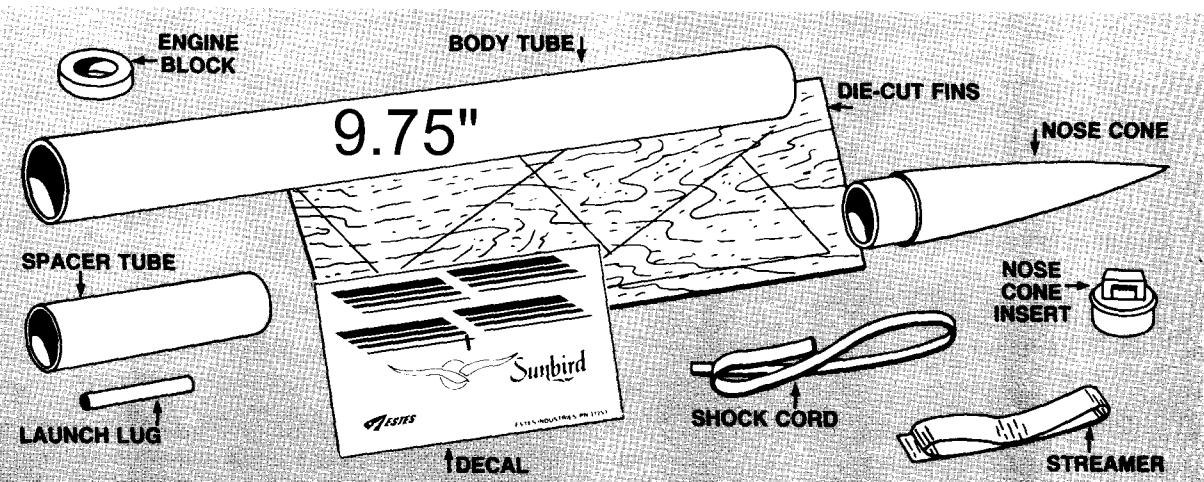
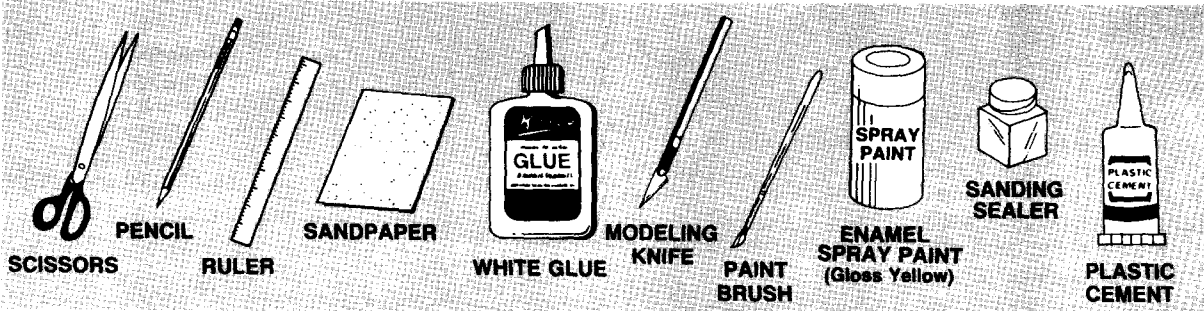

# ROCKET ASSEMBLY

## 1

- A. Mark spacer tube 1/4 inch from one end.
- B. Apply a ring of glue to inside of body tube about 1 inch from rear of tube.
- C. Insert engine block into end of tube.
- D. Push engine block into tube with spacer tube until mark is even with end of tube.
- E. Remove spacer tube quickly before glue sets. Discard spacer tube.

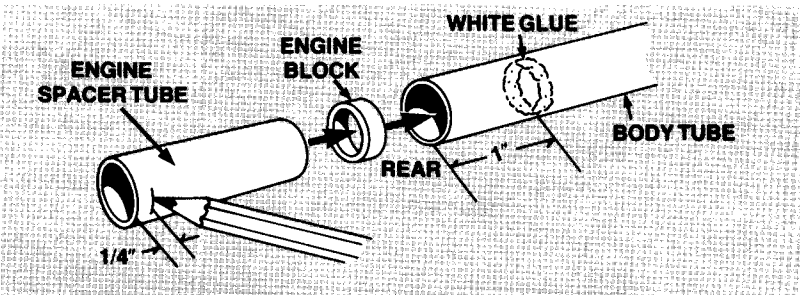

## 2

- A. Stand the body tube upright on the fin guide and mark all fin positions.
- B. Draw straight lines from marks approximately 2 - 3 inches down the body tube.

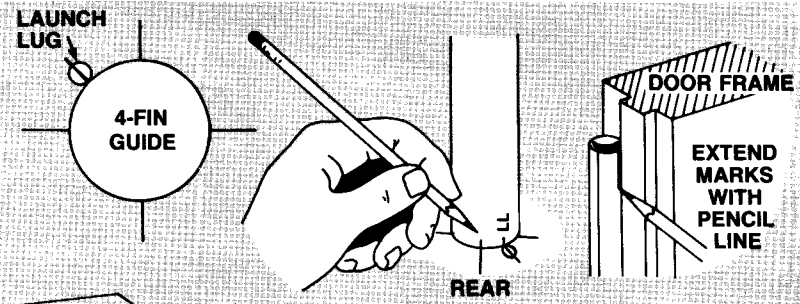

## 3

- A. Fine sand balsa die-cut sheet. Carefully remove fins by freeing with a knife.
- B. Stack fins together. Sand all edges smooth. Round leading edges and trailing edges with sandpaper. Leave root edges and tip edges square.
- C. Glue fins on alignment lines one at a time. Let each dry several minutes before applying next one.
- D. Adjust fins to project straight out from tube. Do not set rocket on fins while glue is wet.

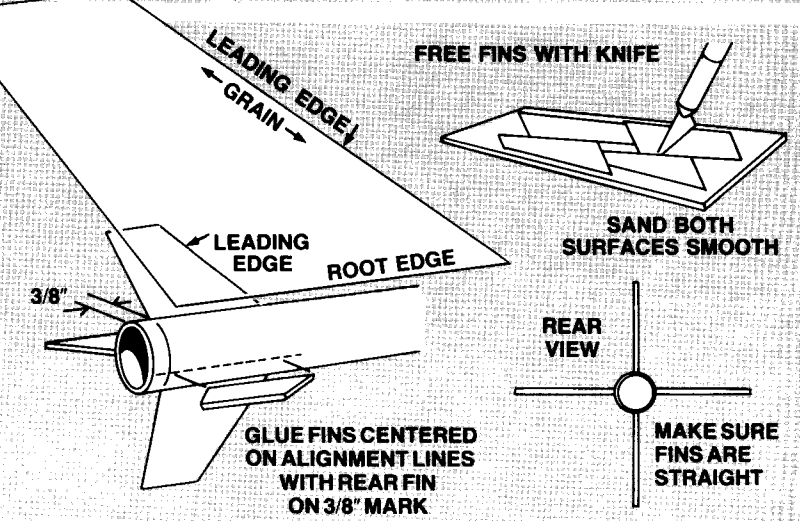

**FINS MUST BE ATTACHED CORRECTLY FOR STABLE FLIGHT!**

## 4

- A. Glue launch lug 2 1/4 inches from rear of rocket on its alignment line.
- B. Apply a glue reinforcement to each fin/body tube joint.
- C. Support rocket as shown until glue dries.

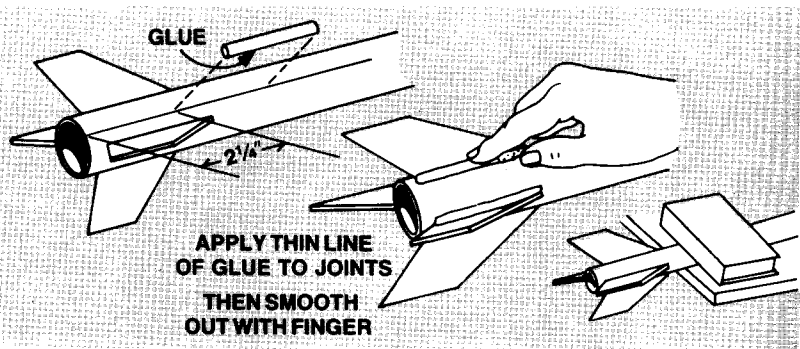

- 5**
- Cut out shock cord mount from front of instructions
  - Crease on dotted lines. Spread glue on section 1 and lay end of shock cord into glue. Fold over and apply glue to back of first section and section 2. Lay shock cord as shown and fold over again.
  - Clamp unit together with fingers until glue sets.

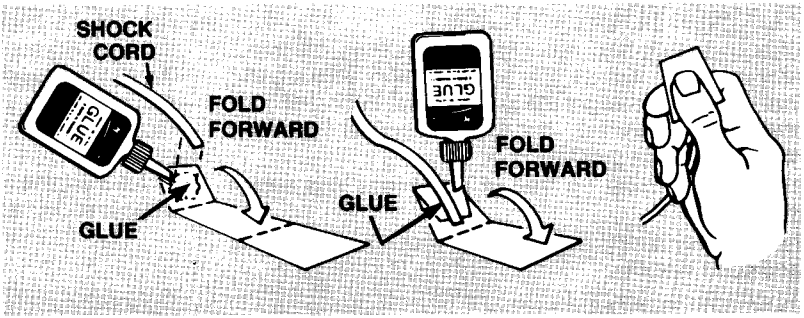

- 6**
- Apply glue to back of shock cord mount.
  - Gently position mount down into front of body tube far enough from front edge of tube to allow nose cone to fit.
  - Press shock cord mount firmly into position.

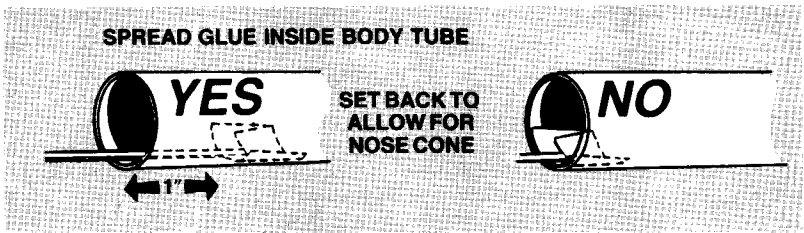

- 7**
- Cement nose cone and nose cone insert together with plastic cement.
  - When cement is dry, tie end of shock cord to nose cone loop with double knot.
  - Tie shock cord around plastic streamer with a double knot as shown.
  - Roll streamer up and put it into body tube along with shock cord and nose cone.

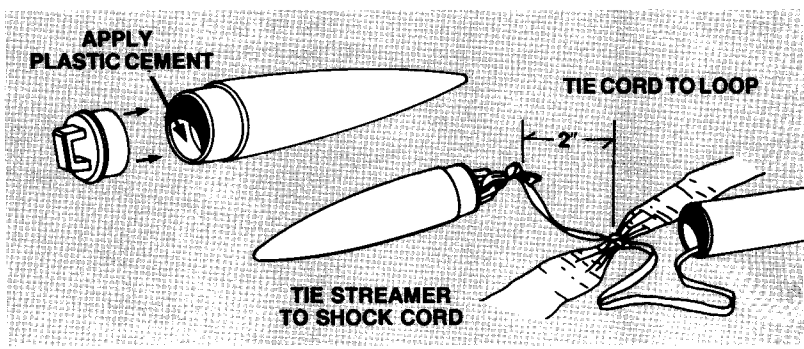

- 8**
- Apply sanding sealer to all wood parts with small brush.
  - When sealer is dry, lightly sand all sealed surfaces. Repeat sanding and sealing until balsa grain is filled and smooth.
  - When sealer and glue are completely dry, paint rocket with yellow spray enamel. Refer to instructions on spray can for best results.



- 9**
- Apply decals as shown. Cut out each decal.
  - Dip decal in lukewarm water for 20 seconds and hold until it uncurls.
  - Slip decal off backing sheet and onto model. Blot away excess water.

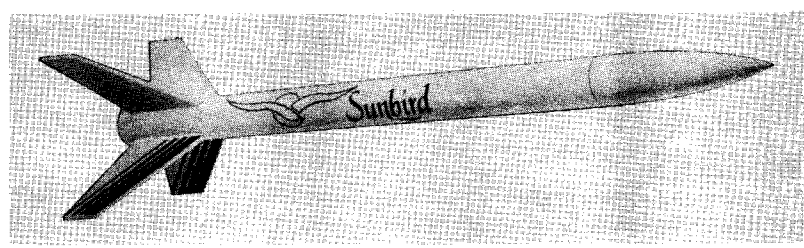

## FLYING YOUR ROCKET

Choose a large field away from power lines, tall trees, and low flying aircraft. Try to find a field at least 250 feet square. The larger the launch area, the better your chance of recovering your rocket. Football fields and playgrounds are great.

Launch area must be free of dry weeds and brown grass.

Launch only during calm weather with little or no wind and good visibility.

## LAUNCH SUPPLIES

To launch your rocket you will need the following items:

—An Estes model rocket launching system

—Estes Recovery Wadding (No. 2274)

—Recommended Engines: 1/2A6-2, A8-3, B4-4, B6-4, B8-5, C6-3, C6-5.

Use A8-3 engine for your first flight, to become familiar with your rocket's flight pattern.

## ROCKET PREFLIGHT

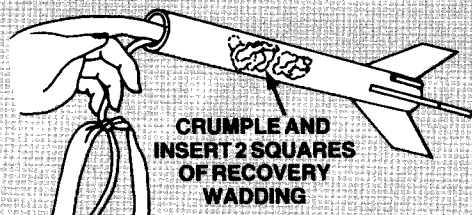

NOTE: If streamer fits too tightly into body, remove and reroll. A too-tight fit could cause an ejection malfunction during flight.

## PREPARE ENGINE

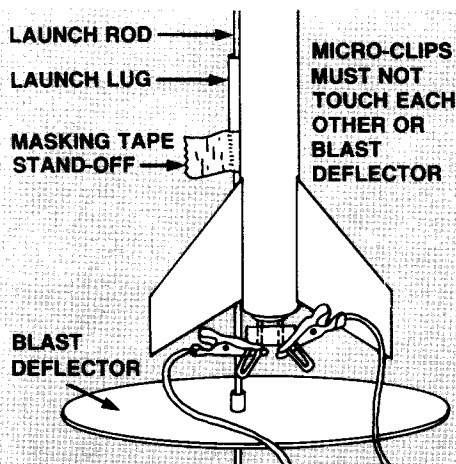
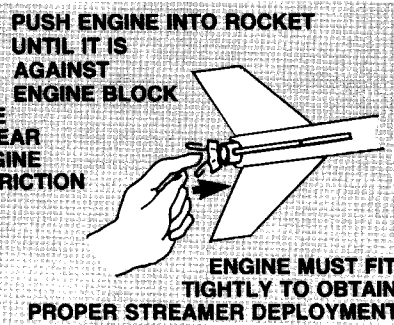
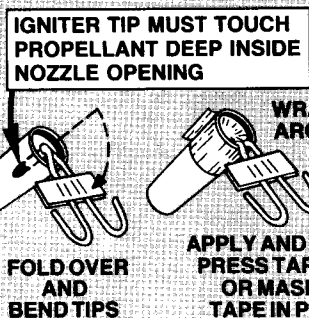
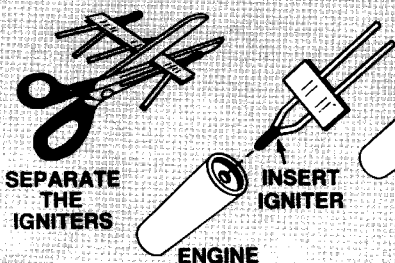

## LAUNCH PROCEDURE

- ⑤ REMOVE SAFETY KEY to disarm the launch controller.
- ④ Remove safety cap and slide launch lug over launch rod to place rocket on launch pad. Make sure the rocket slides freely on the launch rod.
- ③ Attach micro-clips to the igniter wires. Arrange the clips so they do not touch each other or the metal blast deflector. Attach clips as close to protective tape on igniter as possible.
- ② Move back from your rocket as far as launch wire will permit (at least 15 feet).
- ① INSERT SAFETY KEY to arm the launch controller.

**LAUNCH!!!** PUSH AND HOLD LAUNCH BUTTON UNTIL ENGINE IGNITES

Remove safety key—Replace cap on rod.

## MISFIRES

Failure of the rocket engine to function properly is nearly always caused by a failure to install the igniter correctly. This failure permits the igniter to heat and burn into two pieces without igniting the engine.





*Sunbird*



A DAMON COMPANY

ESTES INDUSTRIES PN 37253

# Sunbird

## FLYING MODEL ROCKET

SKILL LEVEL 1

1-Beginner 2-Intermediate 3-Ordinary  
4-Advanced 5-Expert

- Die-Cut Fins
- Streamer Recovery
- Sport Flyer

Length: 13 in. (33 cm)

Dia: .736 in. (18.7 mm)

Weight: .64 oz (18.2 g)

Engine Types: 1/2A6-2,  
A8-3 (First Flight), B4-4,  
B6-4, B8-5, C6-3, C6-5,  
C6-7

FLIGHTS  
UP TO  
1,200 FEET!

Recommended for ages 10 to adult.  
Adult supervision suggested for  
those under 12 years of age when  
flying model rockets. This is a hobby  
kit requiring assembly. Engines,  
launch system, glue and finishing  
supplies are not included.



#1936

ESTES INDUSTRIES  
GREENSBORO, NC 27409 USA

