

THE BLACK HOLE

Space Probe

SKILL LEVEL 2
- Recommended for Intermediate Rocketeers

BEFORE YOU START

COMPLETE THESE INSTRUCTIONS FIRST
(Pages 1 - 4)

Read all instructions before beginning work on your model. Make sure you have all parts and materials. When you are thoroughly familiar with the assembly procedure, begin construction. Check off each step as you complete it. In each step, test-fit the parts together before applying any glue. If some part doesn't fit properly, sand lightly or build-up as needed for precision assembly.

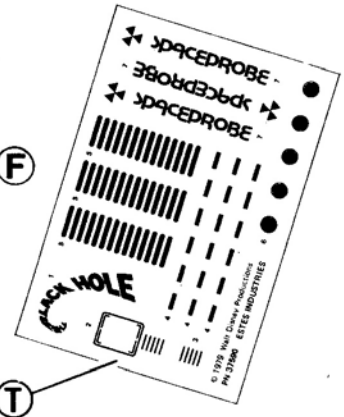
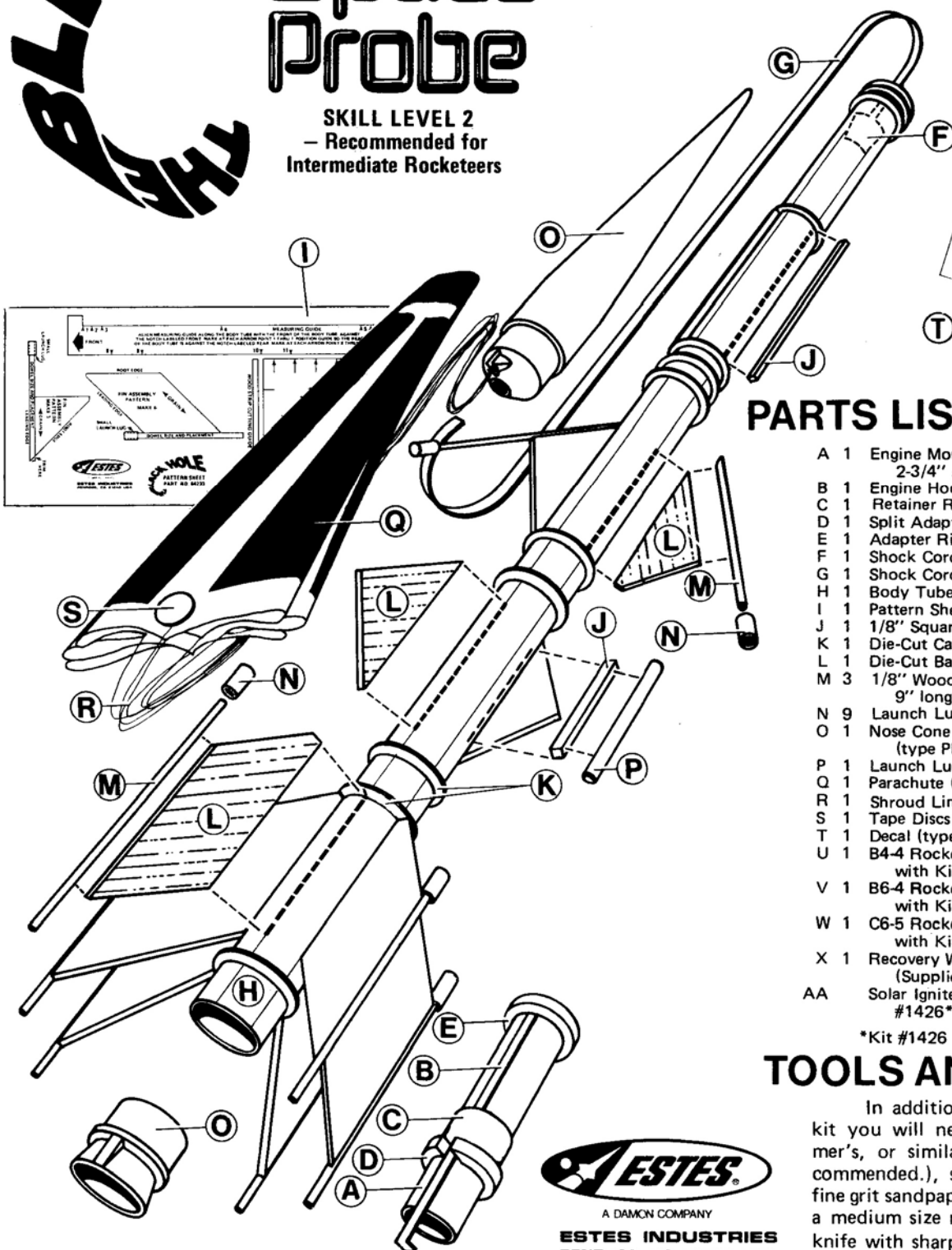

PARTS LIST KIT NO.1426

- A 1 Engine Mount Tube (type BT-20J) 2-3/4" long 30326
- B 1 Engine Hook (type EH-2) 35025
- C 1 Retainer Ring (type HR-20) 30168
- D 1 Split Adapter Ring (type AR-2050S) 80425
- E 1 Adapter Ring (type AR-2050) 30164
- F 1 Shock Cord Mount (type SCM-50) 84444
- G 1 Shock Cord (type SC-1) 85730
- H 1 Body Tube (type BT-50) 18" long 30352
- I 1 Pattern Sheet (type SP-1350) 84233
- J 1 1/8" Square Wood Strip 12" long 85923
- K 1 Die-Cut Card (type TA-1350) 32950
- L 1 Die-Cut Balsa Sheet (type BF-1426) 32380
- M 3 1/8" Wooden Dowels (type WD-1S) 9" long 85904
- N 9 Launch Lugs (type LL-2AM) 3/8" long 38176
- O 1 Nose Cone and Display Nozzle (type PNC-508B) 71027
- P 1 Launch Lug (type LL-2B) 2-3/8" long 38178
- Q 1 Parachute (type PK-12A) 85564
- R 1 Shroud Line (type SLT-72) 72" long 38237
- S 1 Tape Discs (type TD-3F) 38406
- T 1 Decal (type KD-1350) 37590
- U 1 B4-4 Rocket Engine (Supplied Only with Kit #1426*) 80252
- V 1 B6-4 Rocket Engine (Supplied Only with Kit #1426*) 80260
- W 1 C6-5 Rocket Engine (Supplied Only with Kit #1426*) 80292
- X 1 Recovery Wadding (type RP-1C) (Supplied only with Kit #1426*) 85717
- AA Solar Igniters (Supplied Only with Kit #1426*) 85551

*Kit #1426 is the Estes Black Hole Starter Kit.

TOOLS AND MATERIALS

In addition to the parts included in this kit you will need: white glue, (Titebond, Elmer's, or similar household white glue is recommended.), scissors, pencil, fine and extra-fine grit sandpaper, sanding sealer, masking tape, a medium size modeling paint brush, modeling knife with sharp blade, ruler, and metallic light blue enamel spray paint, and a bottle of chrome silver enamel paint (for optional decor).



ASSEMBLY INSTRUCTIONS

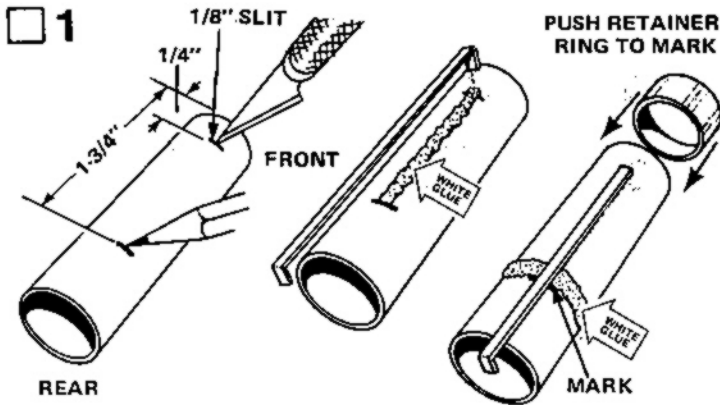

Mark the engine mount tube (part A) at 1/4" and 1-3/4" from one end. Cut a 1/8" long slit in the tube at the 1/4" mark as shown. Apply a dab of white glue to the slit and a line of glue between the slit and the 1-3/4" mark. Push one end of the engine hook (part B) into the slit. Be sure that the hook runs straight along the tube. Apply a line of glue around the engine mount tube just ahead of the 1-3/4" mark. Slide the retainer ring (part C) onto the front of the tube over the engine hook and back to the mark.

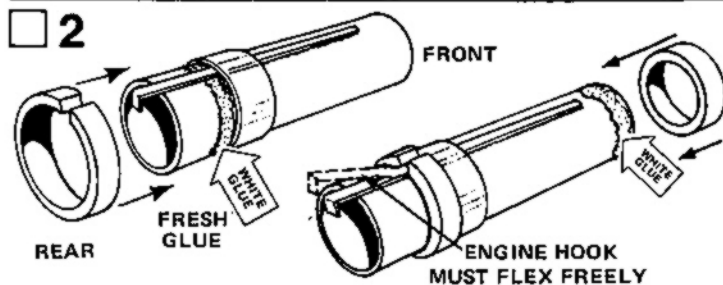

Apply another line of glue around the engine tube just behind the retainer ring. Slide the split adapter ring (part D) onto the rear of the tube and up against the retainer ring. Be sure the notch is centered over the hook, and the hook is straight along the tube. The engine hook must be free to flex slightly as shown. Glue the other adapter ring (part E) to the front of the tube.

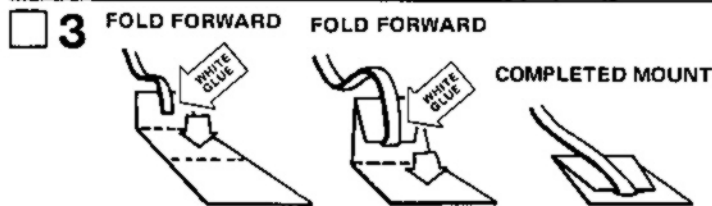

Cut out the shock cord mount (part F). Crease it on the dotted lines by folding. Spread glue on the first section (1) and lay the end of the shock cord (part G) into the glue. Fold over and apply glue to the back of the first section and the exposed part of section (2). Lay the shock cord as shown and fold over again. Clamp the unit together with your fingers until the glue "sets".

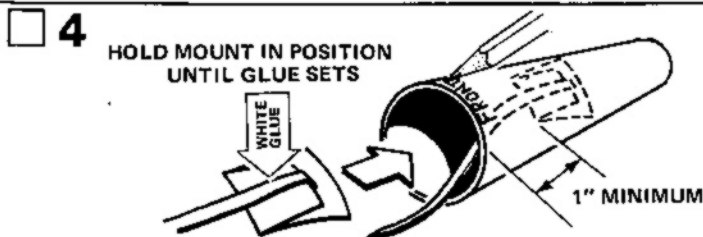

Smear glue over the entire back side of the shock cord mount. Hold the mount as shown and press it into place inside one end of the rocket body tube (part H). Make sure the front of the mount is at least 1" from the end of the tube. Hold the mount in place until the glue "sets". Mark this end of the tube "front" as shown.

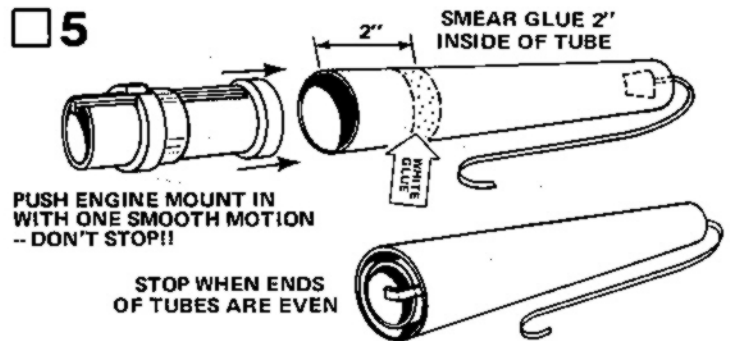

Be sure that glue on the engine mount tube (from step 2) is dry before doing step 5. Smear a 1/8" wide line of glue around the inside of the other end of the rocket body tube (the end away from the shock cord mount). Use a small stick or wood dowel to apply the glue approximately 2" from the end of the tube. Push the engine mount unit in so that the hook will stick out of the end of the body tube! Push the engine mount in with one smooth motion (DON'T STOP!) until the end of the tubes are even. This end of the body tube is the "rear".

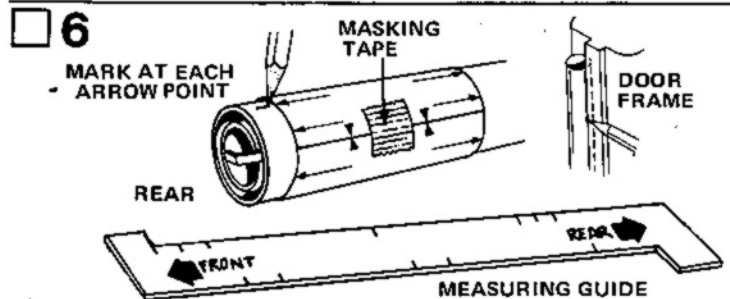

Cut out the body tube marking guide and the measuring guide from the pattern sheet (part I). Wrap the marking guide around the body tube. Match the printed guide marks and tape the guide ends together. Align this joint in the marking guide with the engine hook and mark the tube at each arrow point, front and rear. Draw a straight line connecting each pair of marks. Place the body tube against the inside edge of a door frame as shown. Draw all lines the entire length of the tube.

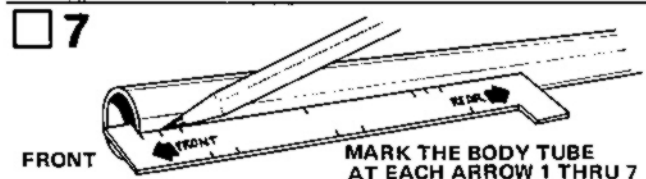

Place the measuring guide along the rocket body tube so that the measuring guide is midway between two fin lines. Place the front of the rocket body tube against the notch in the measuring guide so that the arrow labeled front is pointed toward the front of the body tube. Mark the body tube at each arrow 1 thru 7.

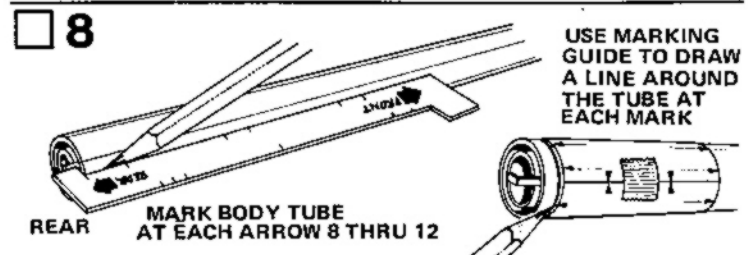

Then place the measuring guide along the tube so the rear of the rocket body tube is against the notch in the measuring guide and the arrow labeled rear is pointed toward the rear of the body tube. Midway between the same two fin lines mark the body tube at each arrow 8 thru 12. Slip the fin marking guide back onto the body tube and using one end of the marking guide as a guide, draw a line all the way around the tube at each of the 12 marks as shown, and mark its corresponding number on the tube.

9

CAREFULLY SAND AND CUT 1/8" WOOD STRIPS

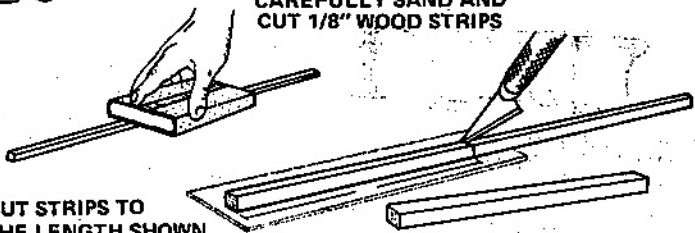

CUT STRIPS TO THE LENGTH SHOWN ON THE PATTERN SHEET

Locate the 1/8" square wood strip (part J) and fine-sand all the sides until smooth. Using the drawing on the pattern sheet labeled 1/8" square strip, lay the wood strip on the drawing and cut to the length shown. Make three identical pieces. Save the left-over wood to be used later.

10

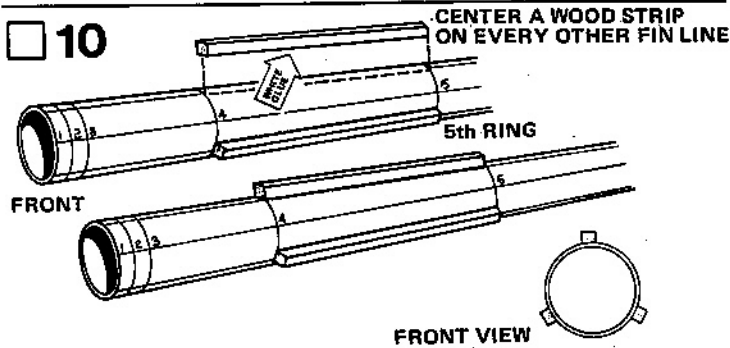

Glue one of the three wood strips centered on any one of the fin lines. The rear of the strip must be at the fifth tube line from the front of the tube. Then skip a fin line and glue another wood strip centered on the next fin line with the rear of the strip on the same fifth tube line as before. Then skip another fin line, and glue the last wood strip centered on the next fin line. Make sure the rear of the strip is in the same position as the two previous strips. Looking from the front end of the tube rearward, the strips should be positioned as shown in the front end view.

11

CAREFULLY REMOVE RINGS WITH A SHARP KNIFE

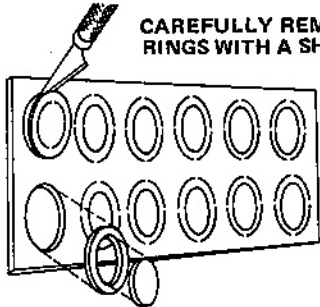

Remove all twelve rings from the die-cut card (part K). Use a sharp knife to free the parts.

12

DIE-CUT RINGS

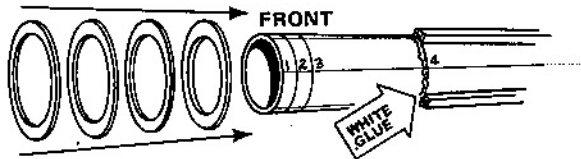

SLIDE A RING TO LINE OF GLUE AND BACK AGAINST THE WOOD STRIPS

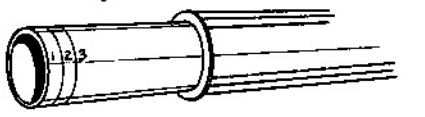

REPEAT FOR OTHER RINGS BY APPLYING GLUE AT RING MARKS AND POSITIONING RINGS AS SHOWN

COMPLETED FRONT RING ASSEMBLY

Apply a thin line of glue around the body tube at the fourth tube line from the front and on the front ends of the wood strips. Slide one of the 12 rings down the body tube onto the line of glue and against the wood strips. Then apply another thin line of glue around the body tube at the third tube line from the front. Slide another ring in place on this tube line. Repeat adding rings for number 2 and number 1 tube lines.

13

DIE-CUT RINGS

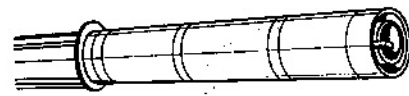
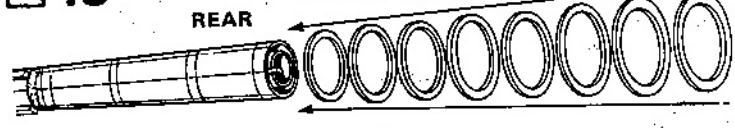

SLIDE A RING TO LINE OF GLUE AND BACK AGAINST THE WOOD STRIP

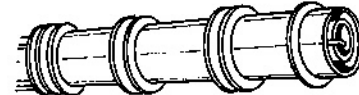

REPEAT FOR OTHER RINGS BY APPLYING GLUE AT RING MARKS AND POSITIONING RING AS SHOWN

After glue has "set" on the first four rings, turn rocket body around so the rear of the body is in your right hand. Apply a thin line of glue around the body tube at the tube line ends of the wood strips. Apply glue to the ends of the wood strips. Slide a ring down the tube onto the glue and against the wood strips. Repeat, applying glue on the tube lines and positioning all the remaining rings. Set the assembly aside to dry.

14

CAREFULLY SAND AND REMOVE FINNS

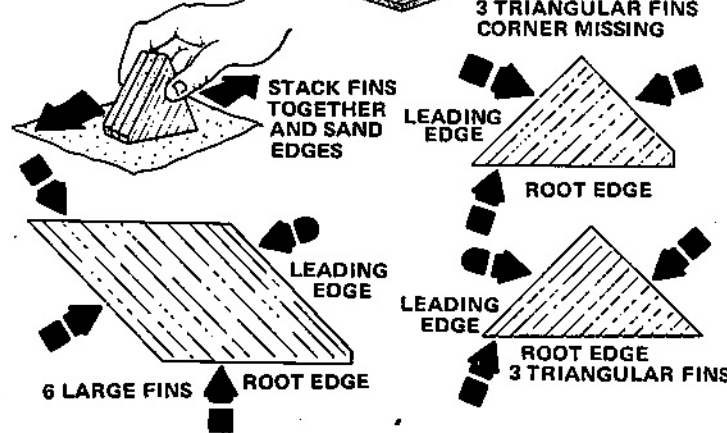
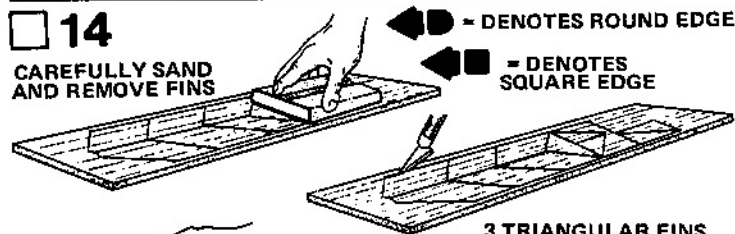

Fine-sand both sides of the balsa fin sheet (part L). Carefully remove the fins from the sheet. Use a sharp knife to cut free the corners and edges. Stack the six large fins, the three triangular fins, and the three triangular fins with one corner missing as shown. Sand all edges smooth and straight. Sand round the leading edges only. The root edges (body edges) must be square. Be sure to sand the three triangular fins with the corner missing to shape shown on the kit pattern sheet.

15

CUT DOWELS TO LENGTH SHOWN ON PATTERN SHEET

CUT MASKING TAPE TO 3/8" WIDE AND 1-1/4" LONG

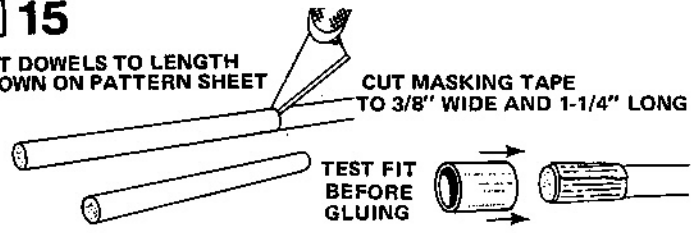

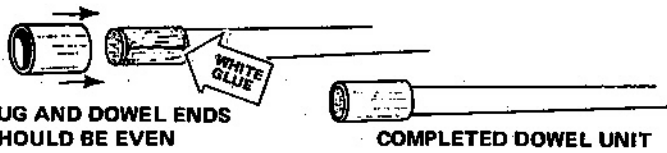

Locate the wooden dowels (part M), and cut 9 dowels to the length shown on the pattern sheet. Cut nine strips of masking tape 3/8" wide and 1-1/4" long. Wrap a strip around one end of each dowel. Test-fit a small launch lug (part N) over the tape. If it is too tight, remove tape 1/16" at a time until the lug fits smoothly on one end of the dowel. Repeat for the other eight dowels. Smear glue over the tape and glue the lug in place on each dowel.

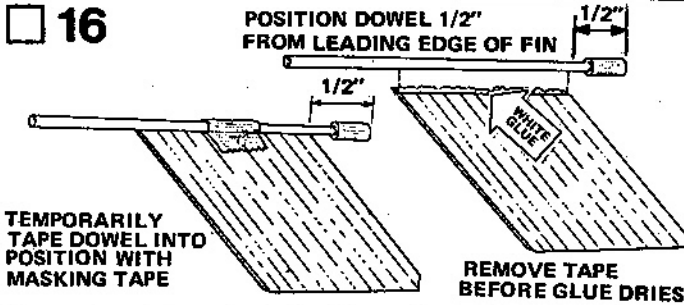

Glue a dowel to each of the 6 large fins as shown on the pattern sheet. The launch lug end of each dowel should project 1/2" forward from the leading edge of each fin. Temporarily tape each dowel in position with a short strip of masking tape until glue dries. Remove tape as soon as glue has set. DO NOT wait till the glue is completely dry.

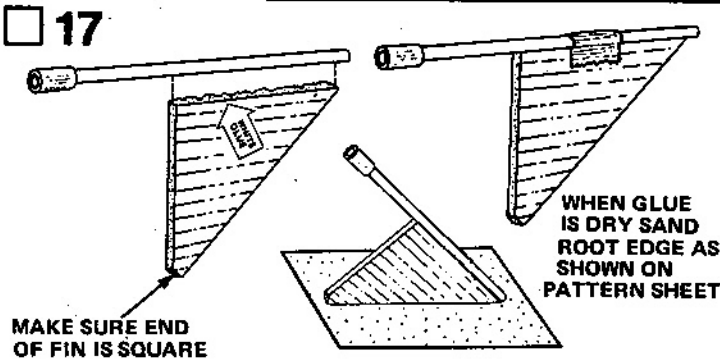

Locate the three triangular fins with the corner missing and glue the remaining three dowels to them as shown on the pattern sheet. When glue is dry, sand root edge of each fin square as shown above.

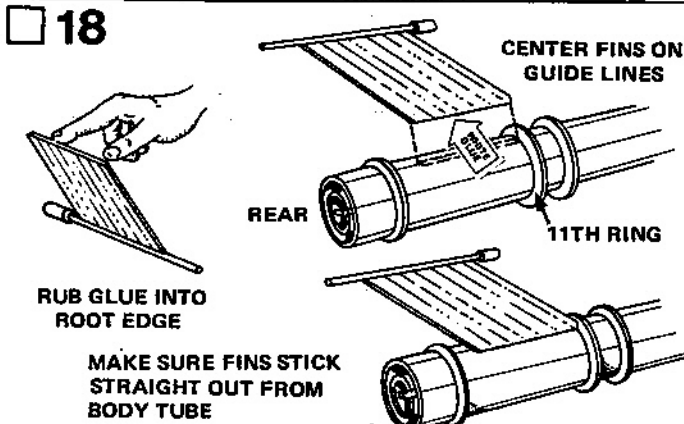

Rub a little glue into the root edge (the edge that attaches to the body) of each of the six large fins. Let the glue set, then apply another line of glue to the fin. Position the fin to the body tube on a fin line as shown. The front end of the fin should be positioned against the number 11 ring as shown. Repeat this procedure for the other five fins. Refer to the illustration to be sure you position the fins correctly.

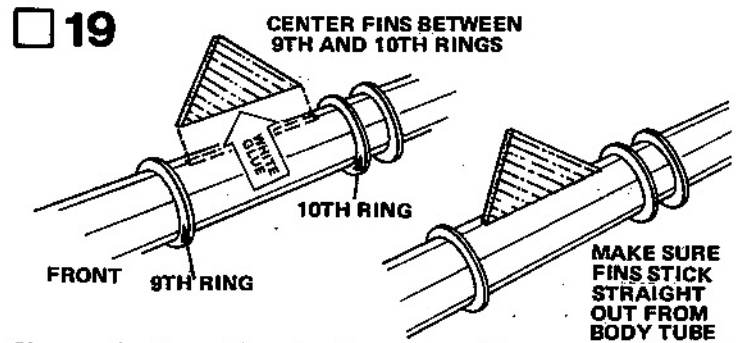

Glue on the three triangular fins, centered between the 9th and 10th rings on the tube. Make sure you use the fin lines between (not same lines as) the three wooden strips at the front of the tube attached in step 10.

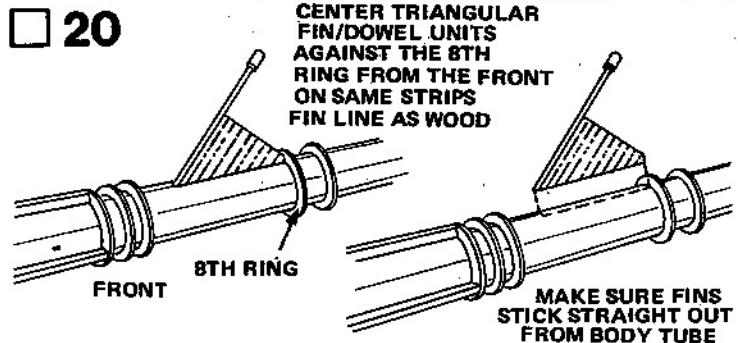

Glue the remaining triangular fin/dowel units against the 8th ring from the front end on the same fin lines as the wood strips. DO NOT set the rocket on its fins while glue is wet. To be sure you positioned all the fins correctly, refer to parts illustration on Page 1.

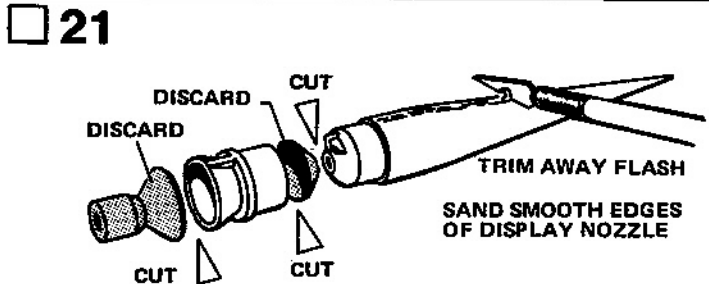

Cut the nose cone (part O₁) and display nozzle (part O₂) from the molded plastic piece (part O). Use a modeling razor saw (This step can be done by the careful use of a modeling knife.) to cut through the separation grooves as shown. Make repeated light cuts around the grooves until the parts are cut free. Work carefully to avoid tearing or scratching the plastic. Discard the two shaded sections. Trim and sand smooth all excess plastic (called "flash") from around the plastic parts. Sand smooth the cut edges of the display nozzle. Remove carefully any excess plastic from inside the nose cone eyelet. Wash the nose cone and nozzle in lukewarm, soapy water. Rinse well and dry.

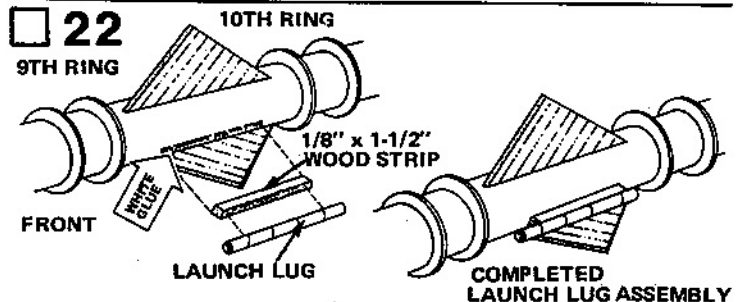

Locate the 1/8" x 1-1/2" long square wood strip left from step 9. Glue strip to tube and fin side of one of the triangular fins centered between the 9th and 10th rings as shown. Then glue launch lug (part P) to the top of the strip so it is centered on the strip and fin.

23

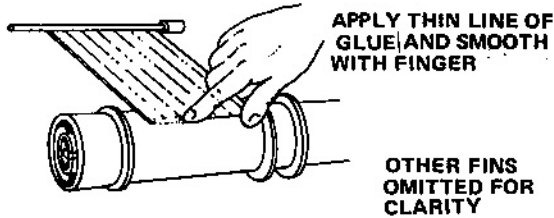

When the fin joints have dried, apply glue reinforcements to each fin. Hold the model level and apply a line of glue to both sides of each fin joint. Rub glue into the balsa fin and the body tube at the joint. Smooth out the glue with your finger. Keep the model level until the glue dries.

24

APPLY TWO COATS SANDING SEALER

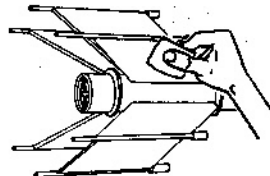
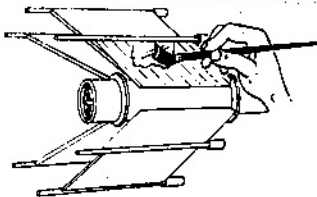

SAND WITH EXTRA-FINE SANDPAPER

When all glue on the outside of the model is dry, prepare the balsa fins for painting. Apply at least two coats of sanding sealer to the fins and wood strips. Let dry and sand lightly with extra-fine sandpaper between coats. Do this until the tiny grain lines in the wood are filled and everything looks and feels smooth.

25



PRESS TAPE DISC DOWN FIRMLY

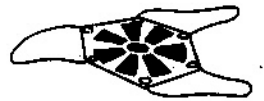

COMPLETED 'CHUTE

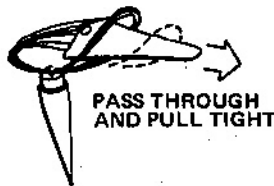

PASS THROUGH AND PULL TIGHT

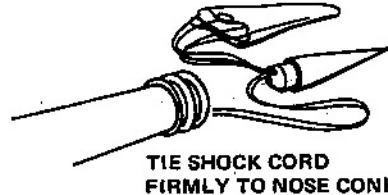

TIE SHOCK CORD FIRMLY TO NOSE CONE

Cut out the parachute (part Q) on its edge lines. Cut three 24" lengths of shroud line (part R). Attach line ends to the top (printed side) of the parachute with tape discs (part S) as shown. Pass the shroud line loops through the nose cone eyelet. Pass the parachute through the loop ends and pull the lines tight against the eyelet. Tie the free end of the shock cord to the eyelet with a double knot. Pack 'chute and shock cord into rocket body. Slide nose cone into place.

PAINTING AND DETAILING

26

Paint entire rocket body and nose cone light metallic blue. Apply at least two light coats of spray paint. Hold spray can 8-12 inches from model and use long, even strokes to cover entire rocket. Allow each coat of paint to dry completely. Follow painting instructions on spray can for best results. As optional decor, paint display nozzle with chrome silver bottle paint and a brush.

DECAL PLACEMENT

27

DIP IN WATER 10-20 SECONDS



HOLD UNTIL IT STARTS TO UNCURL

THE SPINNO WINDITION

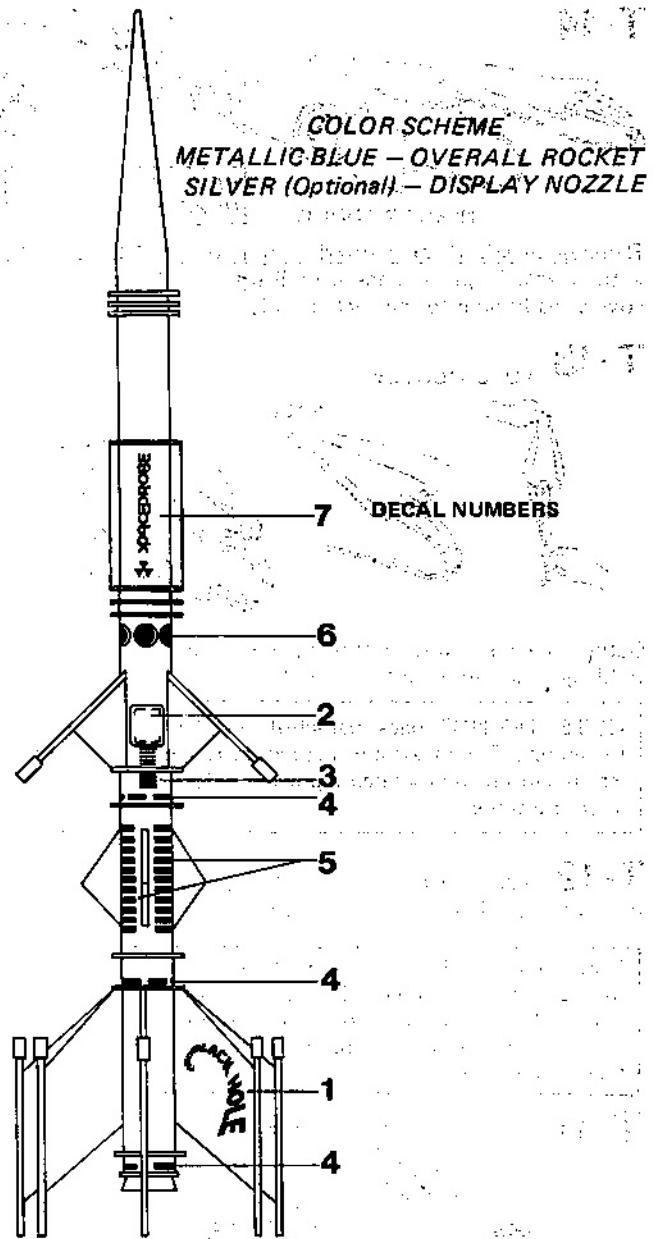

When the paint is completely dry, apply decals (part T). To apply decals, cut out decal section and dip it in lukewarm water for 10-20 seconds. Hold decal until it starts to uncurl or slides easily on the backing sheet. Use a brush to "wet" the model surface where decal will be applied. Slide decal off backing sheet and onto model. Blot excess water away with a cloth. Allow decal model to dry overnight. Apply a final light coat of gloss clear spray enamel over entire model to protect the decals.

LAUNCHING COMPONENTS

- To launch your rocket you will need the following items:
- An Estes model rocket launch system
- Parachute recovery wadding (Estes Cat. No. 2274)
- Recommended engines: AB-3, B4-4 (First Flight), B6-4, C6-5

Be sure to follow the HIAA-NAR* Model Rocketry Safety Code when carrying out your model rocket activities.

*HIAA - Hobby Industry Association of America
NAR - National Association of Rocketry

COUNTDOWN CHECKLIST

T-14

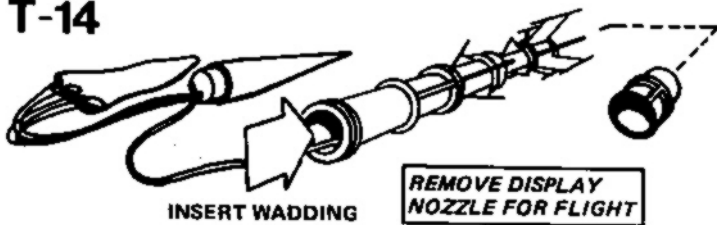

Remove plastic display nozzle from rocket. DO NOT fly rocket with nozzle in place. Pack 4 or 5 squares of loosely crumpled recovery wadding into the rocket body.

T-13

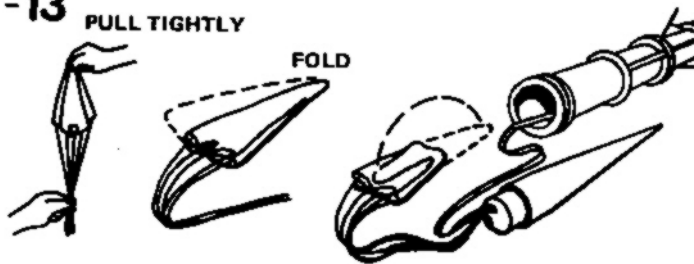

Gather the parachute as shown, then fold into a triangular shape. Fold again and insert into rocket body.

NOTE: DO NOT pack parachute until you are actually ready to launch. For maximum parachute reliability, lightly dust the 'chute with ordinary talcum powder before each flight, especially in cold weather.

T-12

Pack parachute, shroud lines, and shock cord neatly into rocket body. Slide nose cone into place.

Nose cone should separate easily from rocket body tube, but should not be extremely loose. If fit is too tight, sand inside of body tube and shoulder of nose cone with fine sandpaper. If fit is too loose, add a wrapping of transparent tape or masking tape to shoulder of nose cone.

T-11

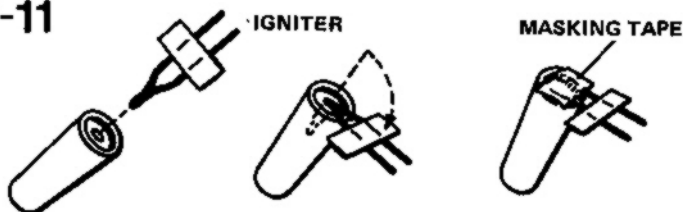

Select an engine and install an igniter as directed in the engine instructions. Use a B4-4 engine for your first flight.

T-10

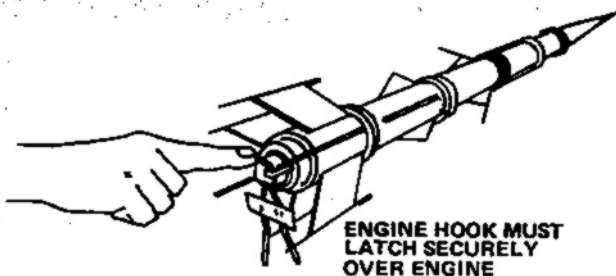

Insert engine into rocket engine mount. Engine hook must latch securely over end of the engine.

T-9

Disarm the launch panel - REMOVE SAFETY KEY!

T-8

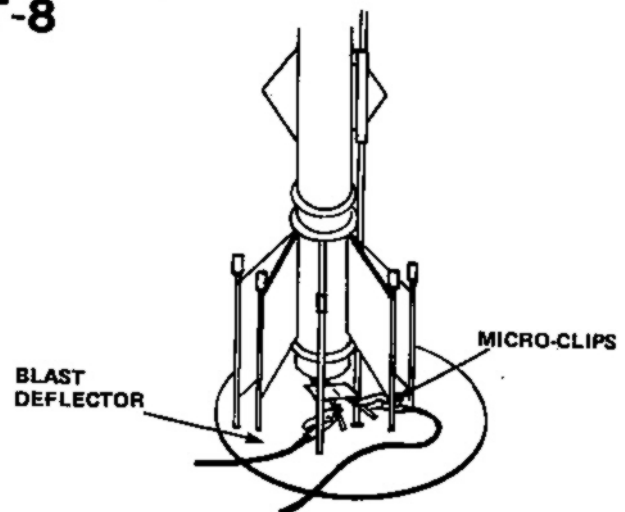

Slide launch rod through rocket launch lug and place rocket on launch pad. Make sure the rocket slides freely on launch rod. Clean the micro-clips and attach them to the igniter wires. Arrange the clips so they do not touch each other or the metal blast deflector. Attach clips as close to engine as possible.

T-7

Clear the launch area, alert recovery crew and trackers. Check for low flying aircraft and unauthorized persons in the recovery area.

T-6

Arm the launch panel - INSERT SAFETY KEY!

-5-4-3-2-1-LAUNCH!!

Repeat Countdown Checklist for each flight.

MISFIRE PROCEDURE

Occasionally the igniter will heat and burn into two pieces without igniting the engine. This is almost always caused by a failure to install it correctly. REMOVE SAFETY KEY from launch panel, remove the model, clean the igniter residue from the engine nozzle, and install a new igniter. Repeat the Countdown Checklist.

CAUTION - WARNING: For your safety DO NOT alter, dismantle, or unwrap model rocket engines or their ingredients in any way. Soak unwanted engines in water to destroy.

ESTES
A DAMON COMPANY
ESTES INDUSTRIES
PENROSE, CO 81260 USA

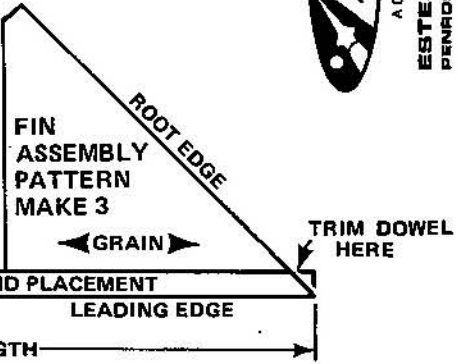
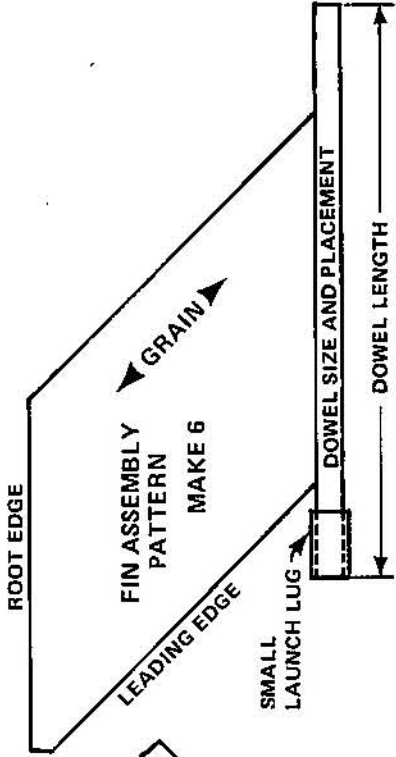
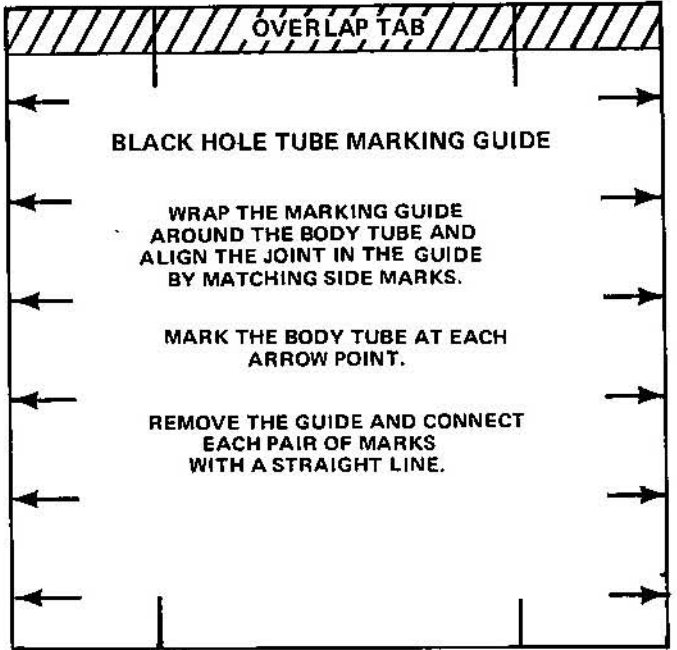
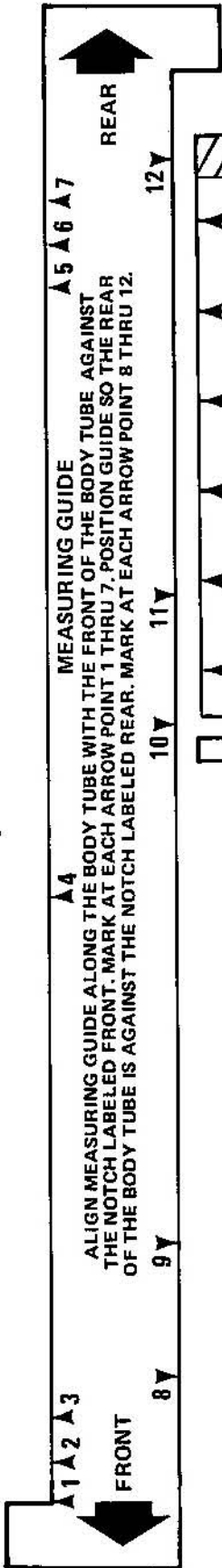

BLACK HOLE
 PATTERN SHEET
 PART. NO. 84233



A DAMON COMPANY
ESTES INDUSTRIES
 PENROSE, CO 81240 USA

THE BLACK HOLE

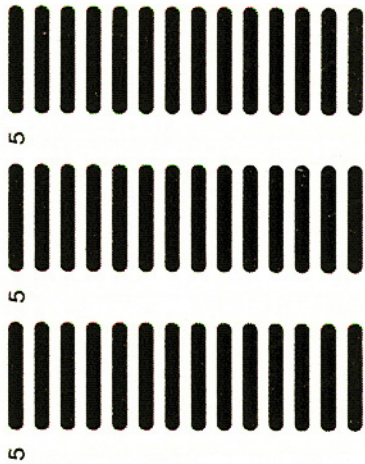

SPACEPROBE 7

SPACEPROBE 7

SPACEPROBE 7

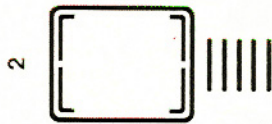

© 1979 Walt Disney Productions
PN 37590 ESTES INDUSTRIES



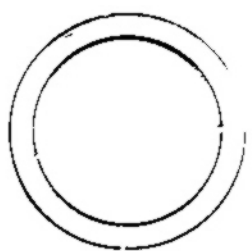
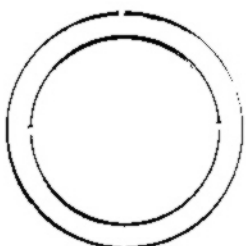
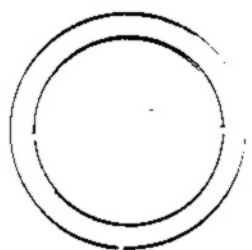
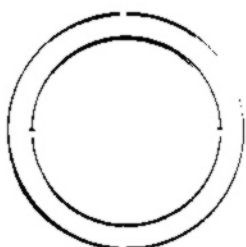
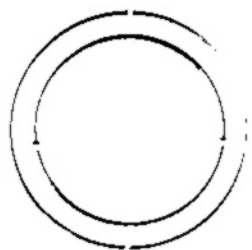
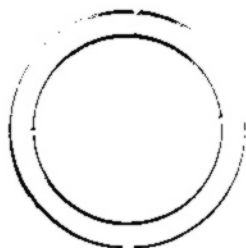
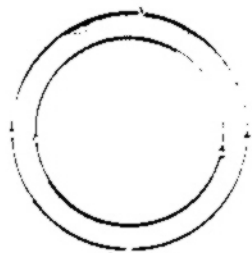

1000

