

SOLAR SAILER

FLYING MODEL ROCKET



GLEAMS LIKE
A JEWEL
HIGH UP
IN SPACE!

SKILL LEVEL 3

1-Beginner 2-Intermediate
3-Craftsman 4-Advanced
5-Expert

Giant 24" Aluminized Solar Sail Recovery 'Chute!

Simulates one of the newest, most sophisticated NASA space concepts for the 1980's. Features printed balsa fins, quick-release engine mount and realistic decals simulating solar panels and girder construction. Truly spectacular recovery with giant 24" Solar sail 'chute.

This is a hobby kit requiring assembly. Recommended for ages 10 to adult. Engines, launch system, glue and finishing supplies are not included. Adult supervision is suggested for those under 12 years of age when flying model rockets.

Flights
Over
600 Feet!

Specifications:

Length: 39" (100 cm)
Diameter: .976" (24.8 mm)
Weight: 2.8 oz (80 g)
24" Solar Sail Recovery 'chute
Recommended Engines:
B6-4 (First Flight) C6-5



A SUBSIDIARY OF DAMON

ESTES INDUSTRIES

PENROSE, COLO. 81240



KIT NO. 1297

solar sailer

Skill Level 3 This kit is suggested for Craftsman Rocketeers.

PARTS LIST

A)	2	Body Tube (type BT-20L)	30330
B)	1	Body Tube (type BT-50FE)	30359
C)	1	Body Tube (type BT-50)	30352
D)	3	Adapter (type AR-2050)	30164
E)	1	Adapter-split (type AR-2050S)	80425
F)	2	Launch Lugs (type LL-2A)	38175
G)	1	Engine Holder (type EH-2)	35025
H)	1	Retainer (type HR-20)	30168
I)	1	Tube Coupler (type JT-20C)	30254
J)	1	Shock Cord (type SC-3)	85744
K)	1	Nose Cone (type BNC-50J)	70256
L)	1	Screw Eye (type SE-1A)	38251
M)	1	Tape Discs (type TD-8)	38408
N)	1	Parachute (type PK-24SS)	38206
O)	1	Shroud Lines (type SLT-216)	38245
P)	1	Printed Balsa (type BF-97) fins	32303
Q)	1	Printed Balsa (type BF-97A) truss	32304
R)	4	Wood Dowel (type WD-1)	32056
S)	1	Decal Sheet (type KD-97)	37102
T)	1	Pattern Sheet (type SP-97)	84037

IMPORTANT:

Read all instructions before beginning work on your model. Make sure you have all parts and materials. When you are thoroughly familiar with the assembly procedure, begin construction. Check off each step as you complete it. In each step, test-fit the parts together before applying any glue. If some part doesn't fit properly, sand lightly or build up as needed for precision assembly.

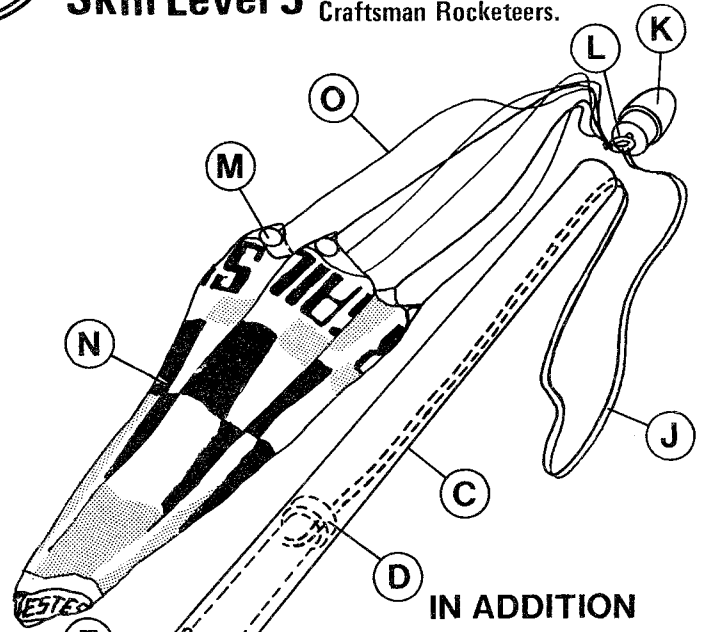

IN ADDITION

You will need a few tools and supplies, so collect them before you start. Here's the list:

- A. White Glue: Estes Rocket Glue, Elmer's, or similar.
- B. Scissors: Almost anything which will cut paper is fine.
- C. Knife: A sharp model knife or single edge razor blade.
- D. Pencil: A pencil is best; ball point ink can show through the paint.
- E. Ruler: Measure distances — don't guess.
- F. Sandpaper: Fine and extra-fine for a smooth finish on your fins.
- G. Sanding Sealer: Fills the holes in the balsa.
- H. Paint: White enamel spray and red enamel spray or "brush-on".
- I. Masking Tape: To anchor shock cord and to mask off for painting red nose.

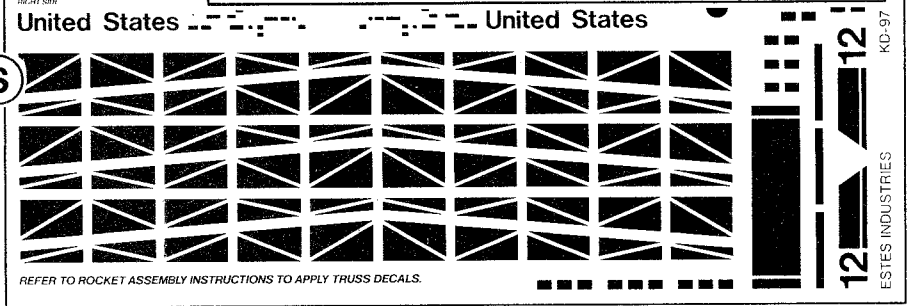
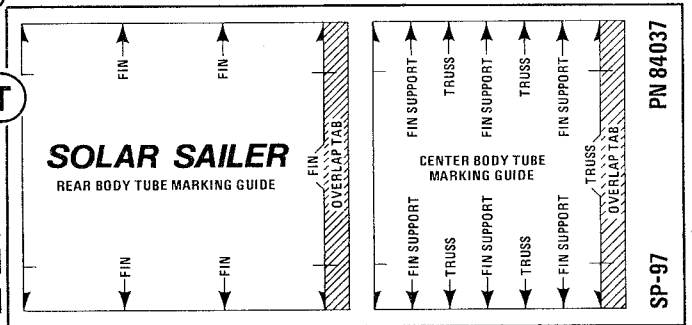
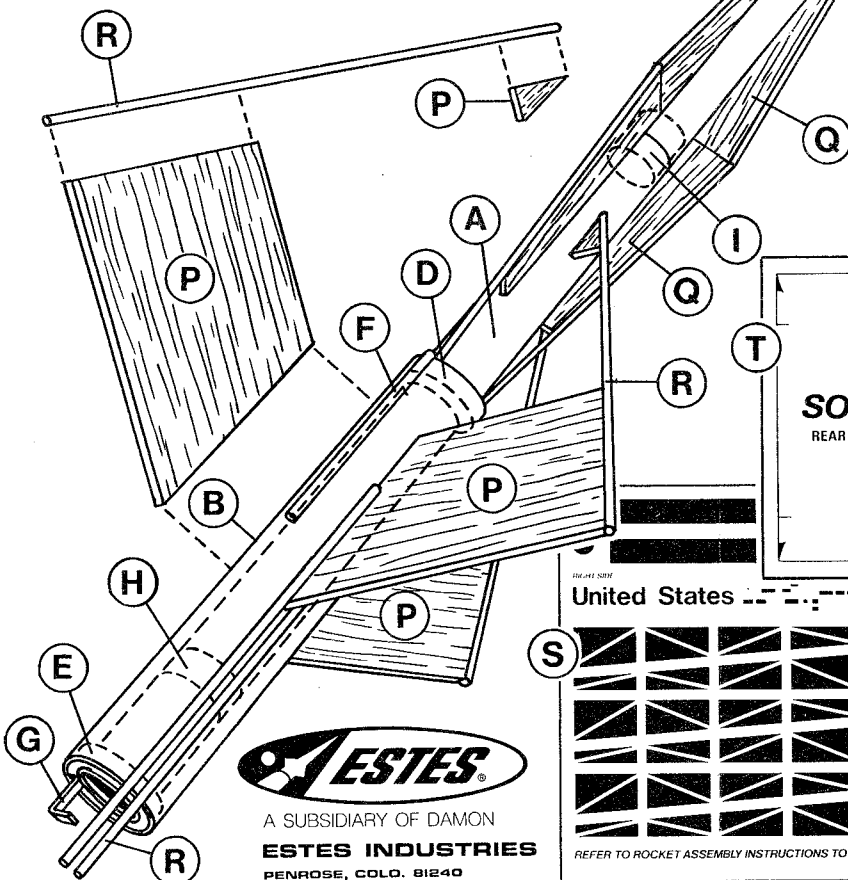

ESTES
A SUBSIDIARY OF DAMON
ESTES INDUSTRIES
PENROSE, COLO. 81240

REFER TO ROCKET ASSEMBLY INSTRUCTIONS TO APPLY TRUSS DECALS.

PN 84037
SP-97
12
ESTES INDUSTRIES
KD-97

ASSEMBLY INSTRUCTIONS

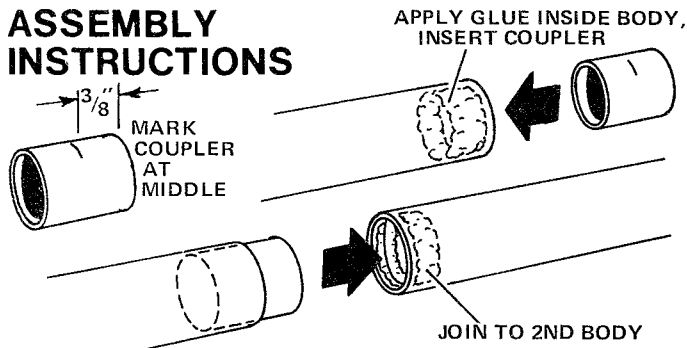

1 Assemble the main body. Mark the tube coupler (part I) at its middle. Smear glue around the inside of one end of a 12" body tube (part A). Insert the coupler into the glued body end so half of the coupler is in the tube. Let the glue set, then smear glue inside one end of the other 12" tube and slide glued end onto the coupler to join the tubes. Lay the assembly on a flat table top and roll gently to make sure the tubes are straight.

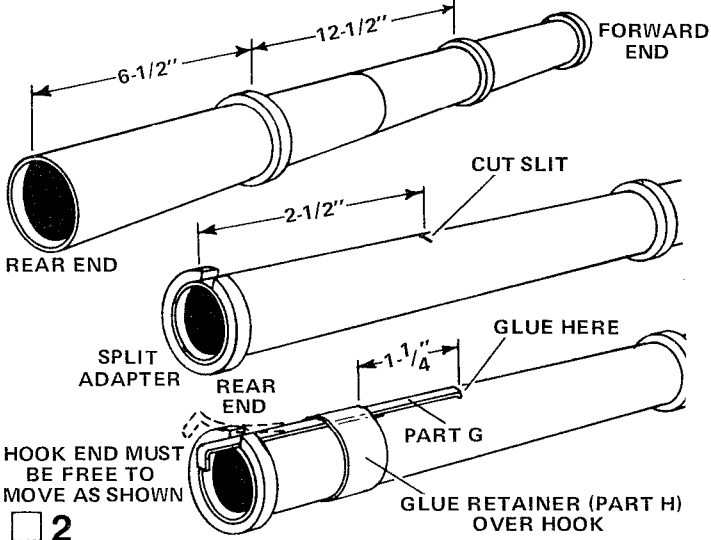

2

- Mark main body tube 6-1/2" from one end (This will become the rear end.) and again 12-1/2" from the first mark (This will be where trusses will be located.)
- Slip adapters (part D) onto tube and glue in place as illustrated.
- Cut a 1/8" wide slit 2-1/2" from the rear end of body tube. Insert one end of the engine holder (part G) in the slit and glue.
- Slide retainer (part H) over engine holder and body tube and glue in place as shown.
- Glue the split adapter ring (part E) flush with the rear end of body tube and so the end of engine holder is free to move up and down in the slit of the adapter.

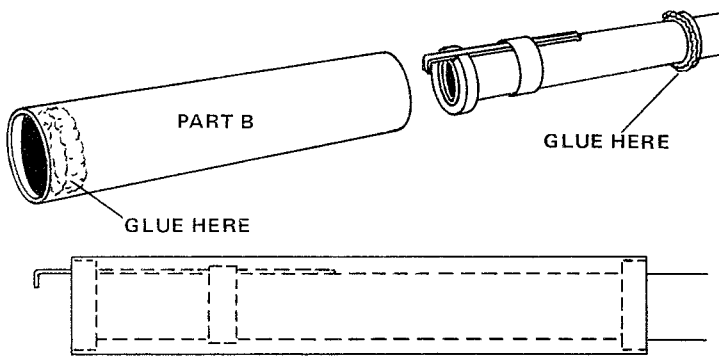

3 Apply glue to the inside of one end of body tube (part B) and to the adapter ring just forward of the engine holder. Slide body tube (part B) into place matching its ends with the adapter rings. Wipe away any exposed glue.

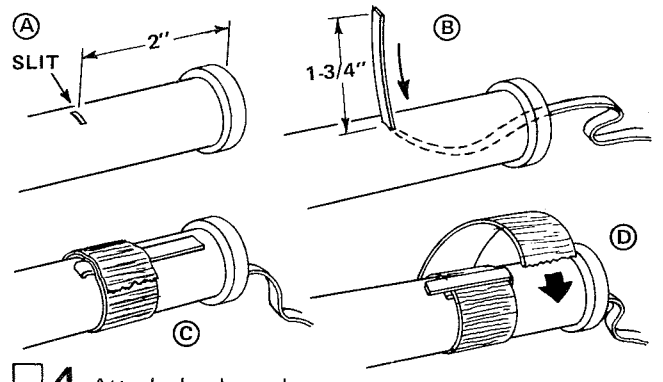

4 Attach shock cord:

- Cut 1/32" X 3/16" slit in forward portion of body tube 2" back from front face of tube.
- Thread shock cord (part J) thru slit and out forward end of body tube. Leave 1-3/4" of shock cord extending out of side of tube.
- Fold shock cord forward and wrap tightly with 3/4" wide masking tape (twice around).
- Fold shock cord back down over tape and wrap a second piece of masking tape twice around body tube over shock cord.

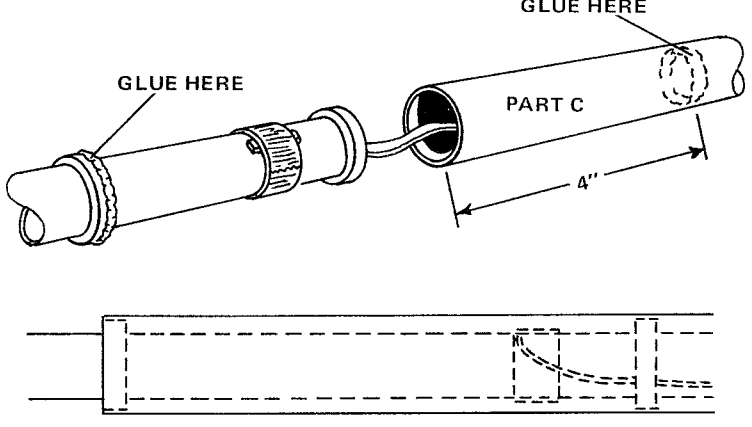

5 Glue body tube (part C) to the two forward adapter rings as shown. Use a small stick or dowel to apply glue to the inside of part C tube approximately 4" in from the rear end.

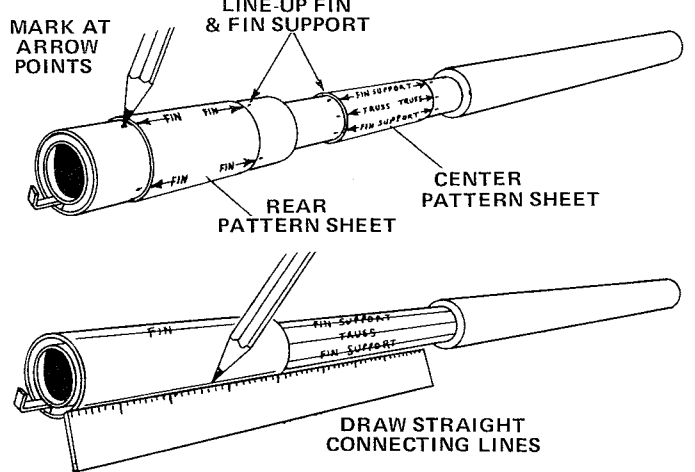

6 Cut the rear and center body tube marking guides out of the pattern sheet (part T). Wrap the marking guides around the respective body tubes and mark tubes at each arrow point as shown. Make sure the points on the center tube guide marked "fin support" are exactly in line with the rear tube "fin" marks. Use a ruler to draw a straight connecting line between each matching pair of marks. Have lines marked "truss" on the center tube extend the full length of the center tube. Mark each line "truss", "fin", etc. so you know which line is which.

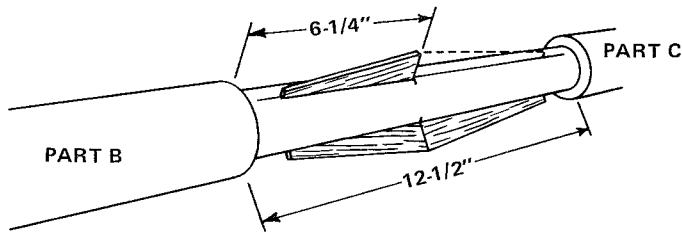

7 Cut out the six parts marked "truss" from the printed balsa sheet (part Q) using a ruler or straight edge and a sharp knife (or single edge razor blade). Sand off lettering on each part. Mark the center line of the center tube, 6-1/4" from each end as shown. Glue each of the six balsa truss sections in place making sure to butt-glue together the high point of each truss piece at the center line of the 12-1/2" space.

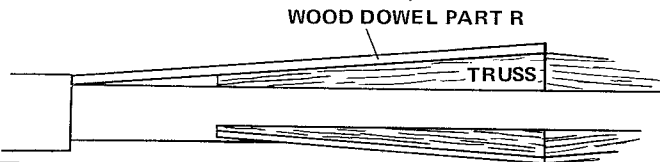

8 When glue in step 7 has hardened, cut sections of wood dowel (part R) to fit on the top edge of each balsa truss part. Sand the ends at a slight angle to fit against the tube adapters and snugly against each other in the center.

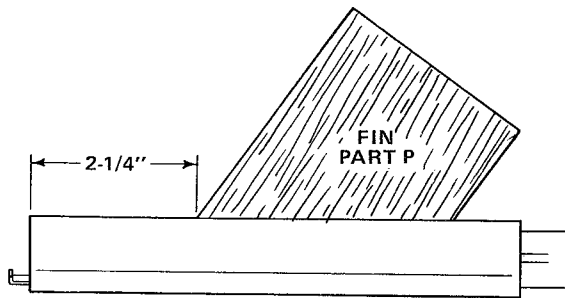

9 Repeat operation 7, cutting fins from balsa sheet (part P) and gluing them in place 2-1/4" from the back edge of rear body tube. Make sure that each fin extends straight out from the body.

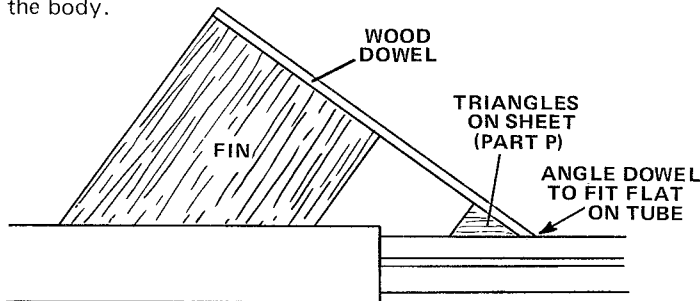

10 When glue applied in step 9 has completely hardened, cut lengths of wood dowel to fit along the top edge of each fin and extending down to the center body tube between trusses. Angle the end of each dowel to fit flush with the tube. When the glue has hardened, cut the small triangles out from balsa sheet (part P) and glue in the intersection of dowels and tube.

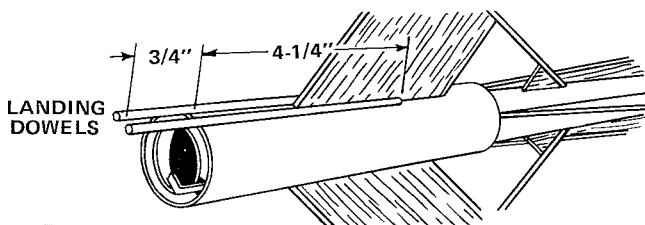

11 Cut two 5" lengths of dowel and glue them to body tube and along each side of one fin so they extend rearward of the back edge of the body tube 3/4". These will protect the engine holder on landings.

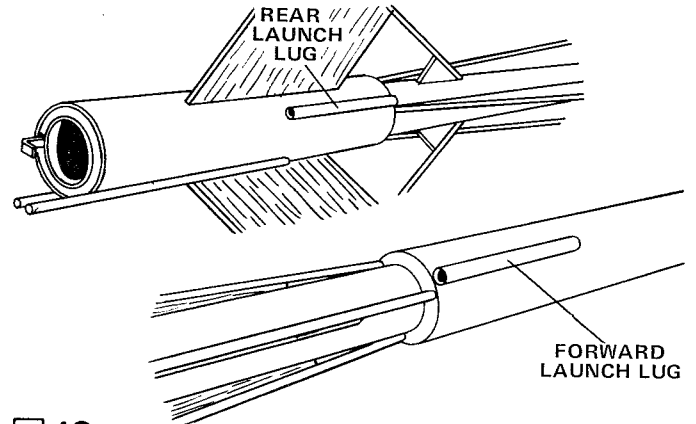

12 Glue the two launch lugs (part F) in position as shown. Make sure they are in line with one another and along side of one truss so launch rod does not rub on side of truss dowels.

A FILLET IS... A smooth joint - built up between body and fin by applying glue along the joint and smoothing the glue with a finger.

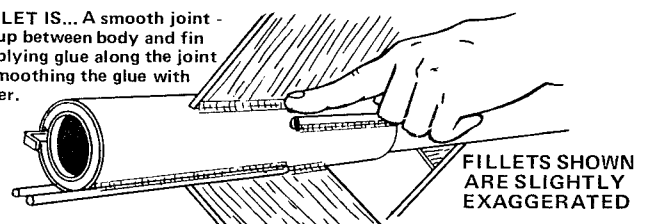

13 Apply a glue "fillet" to each balsa fin joint. Holding the rocket horizontally (level) apply a line of glue to both sides of each joint. Smooth out the glue with your finger. Keep the rocket level until the glue dries.

INSERT SCREW EYE, REMOVE, SQUIRT GLUE INTO HOLE

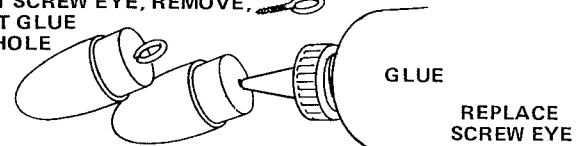

14 Insert the screw eye (part L) into the base of the nose cone (part K). Remove screw eye and squirt a small amount of glue into the hole. Reinsert the screw eye.

(A) BE SURE ALL GLUE HAS DRIED HARD AND CLEAR

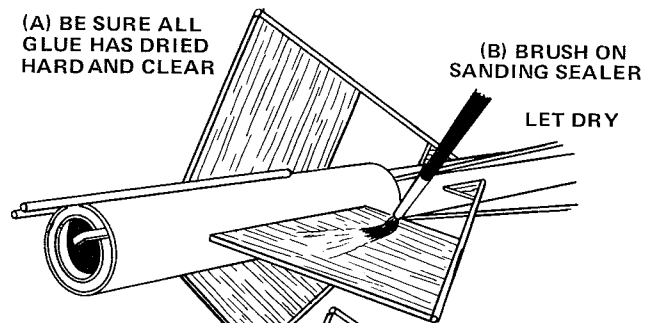

(C) SAND WITH EXTRA FINE SANDPAPER

REPEAT (B & C) AS NECESSARY TO COMPLETELY FILL PORES IN WOOD

15 When all glue on the outside of the model is dry, prepare the balsa parts for painting. Apply at least two coats of sanding sealer to all wood surfaces. Let dry and sand lightly between coats. Do this until the tiny holes in the wood are filled and everything looks and feels smooth. After the sanding sealer

SPRAY PAINT FOR BEST RESULTS. USE STICK OR DOWEL FOR ROCKET HOLDER. SHAKE CAN BEFORE SPRAYING.

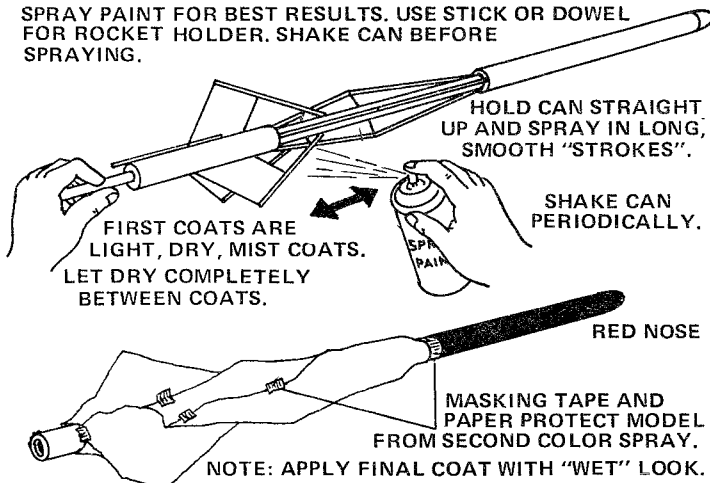

FIRST COATS ARE LIGHT, DRY, MIST COATS. LET DRY COMPLETELY BETWEEN COATS.

SHAKE CAN PERIODICALLY.

RED NOSE

MASKING TAPE AND PAPER PROTECT MODEL FROM SECOND COLOR SPRAY.

NOTE: APPLY FINAL COAT WITH "WET" LOOK.

TO OBTAIN GLOSS, FINAL COAT SHOULD BE SLIGHTLY HEAVIER:

is completely dry, paint the entire model flat white. Let this dry overnight. Next, paint entire model gloss white and allow this to dry overnight. When the gloss white is thoroughly dry, mask off approximately 15" down from front end and paint front end bright red. When red has completely dried, remove masking and proceed with applying decals.

GLOSS WHITE—OVERALL ROCKET
RED—15" OF FRONT END OF ROCKET

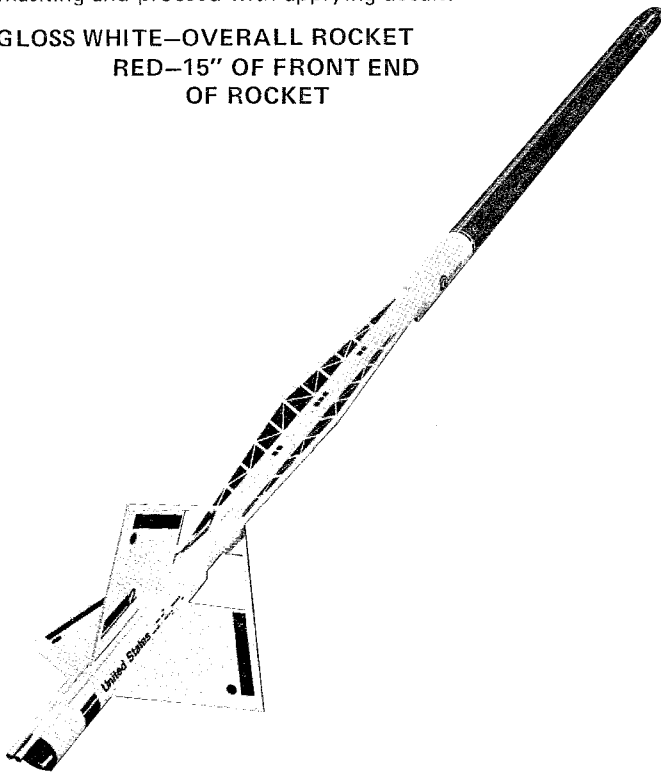

16 When all paint is dry, apply decals (part S). To apply the water transfer decals, cut out an individual section of the decal and dip in lukewarm water for about 10 seconds. When the decal slides freely on the backing paper, slip it from the backing sheet onto the model in the desired position.

Wet desired model locations lightly with water, then slide decal into desired position. Blot excess water away with a damp cloth. Allow decals to dry overnight.

17 Follow instruction steps 1 through 4 on your Solar Sail parachute to attach shroud lines and tape discs to chute and then attach shroud lines and shock cord to nose cone.

As an alternate to the chute instructions and to allow printed side of Solar Sail to be on the under side and more visible during descent, locate the attachment of shroud lines and tape discs on the unprinted side, simply make a small pin hole in each printed disc center, and then center each tape disc on this hole on the unprinted side.

COUNTDOWN CHECKLIST

T-14 Pack four squares of crumpled recovery wadding loosely into body tube.

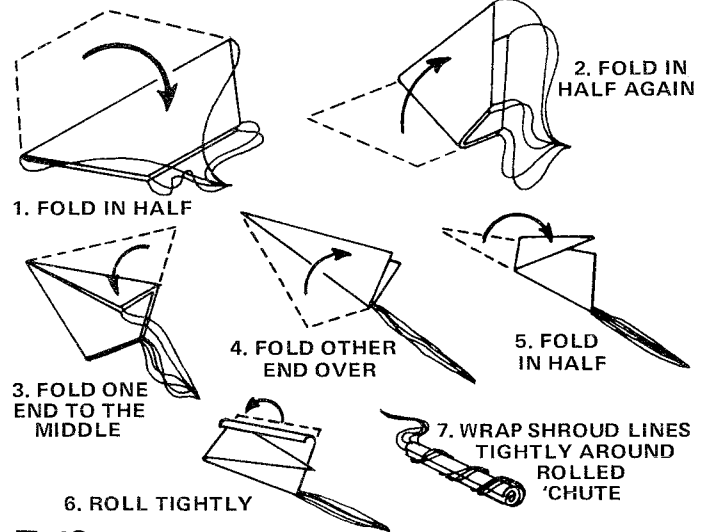

T-13 Make as small a "package" of your "Solar Sail" as possible, see illustration above. "Sail" should slide easily in and out of body tube.

T-12 Pack shock cord neatly into rocket.

NOTE: DO NOT pack parachute until you are actually ready to launch. For maximum parachute reliability, lightly dust 'chute with ordinary talcum powder, especially in cold weather.

Slide nose cone into place. Nose cone should separate easily from rocket body tube, but should not be extremely loose. If it is too tight, sand inside of body tube and shoulder of nose cone with extra fine sandpaper. If nose cone is too loose, add a wrapping of transparent tape or masking tape to shoulder of nose cone.

T-11 Select an engine and install an igniter as directed in the engine instructions. Engines recommended for use with this rocket are B6-4 and C6-5.

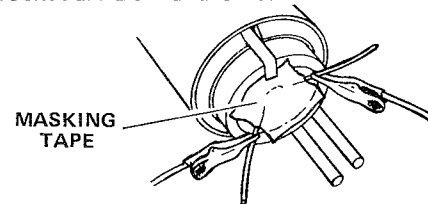

T-10 Insert engine into rocket. Engine hook must latch securely over end of engine.

T-9 Disarm launch panel--remove safety key.

T-8 Place rocket on launch pad making sure rocket slides freely on launch rod. Clean micro-clips and attach them to igniter leads.

T-7 Clear the launch area, alert recovery crew and trackers. Check for low flying aircraft and unauthorized persons in recovery area.

T-6 Arm launch panel--insert safety key.

-5-4-3-2-1-LAUNCH!!

MISFIRE PROCEDURE

Occasionally an igniter will heat and burn in two without igniting the engine. This is almost always caused by a failure to install it correctly. Disarm launch panel, remove the model, clean igniter residue from nozzle and install a new igniter. Follow launching procedure again.

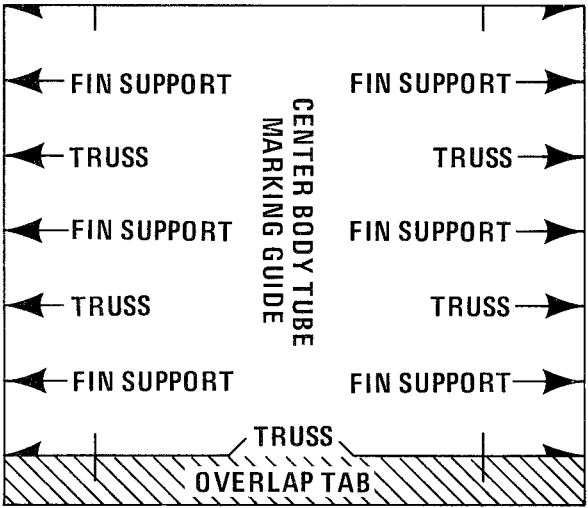
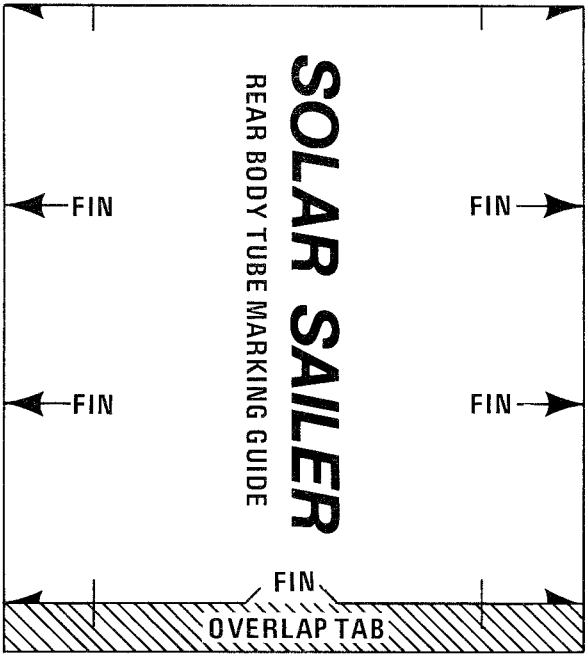

SP-97

PN 84037

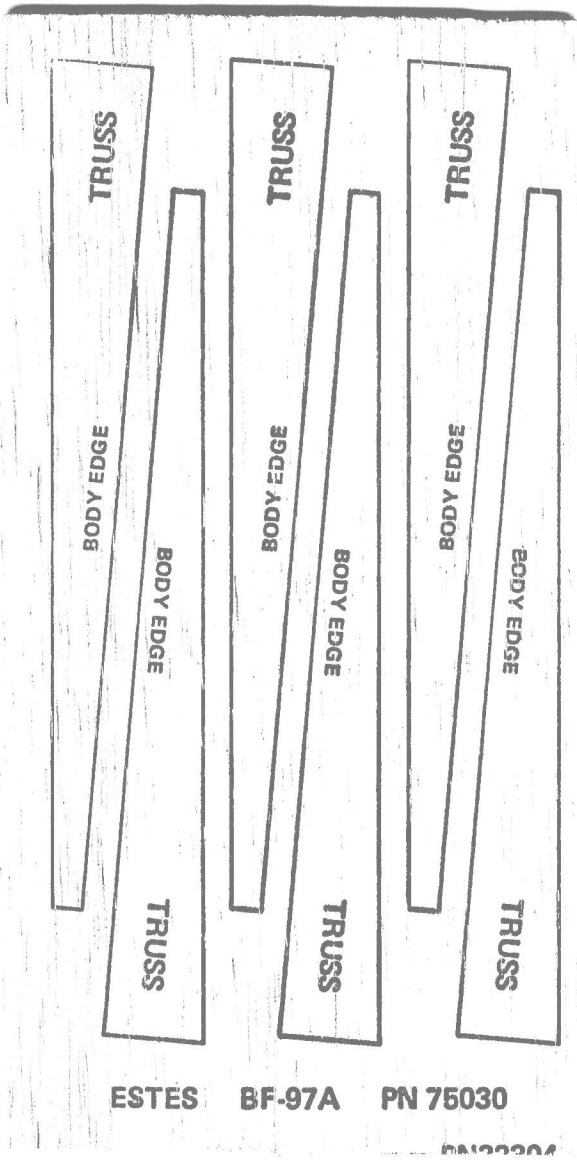
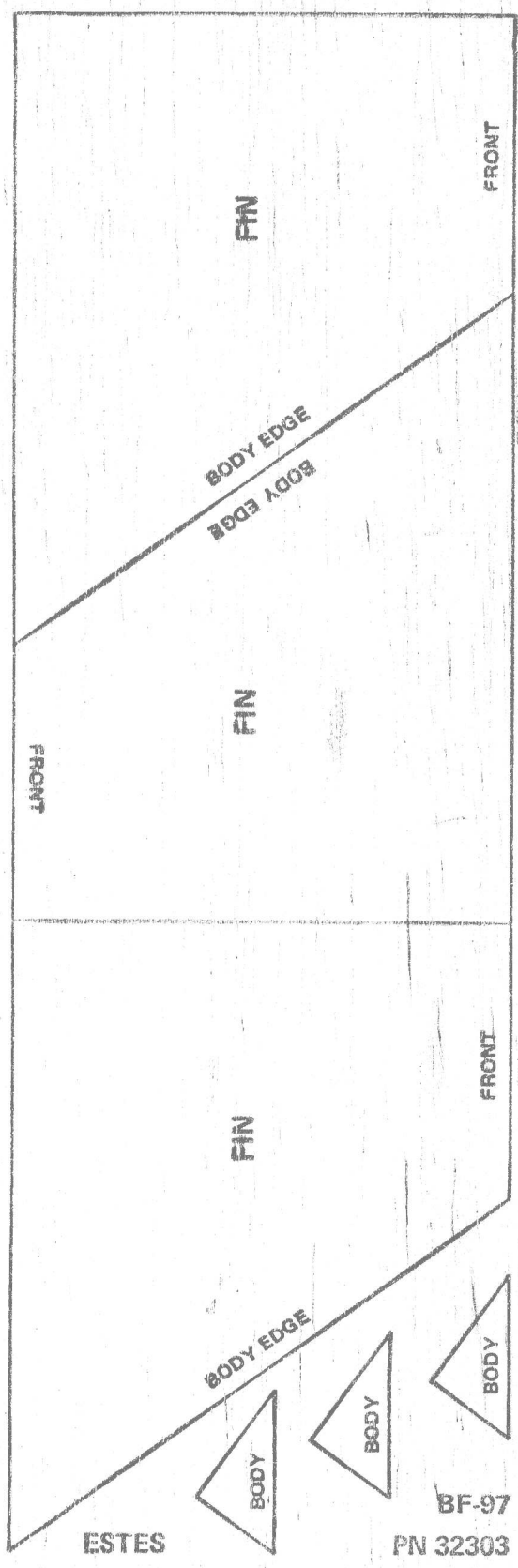



SOLAR SAILER



RIGHT SIDE

United States



United States

LEFT SIDE

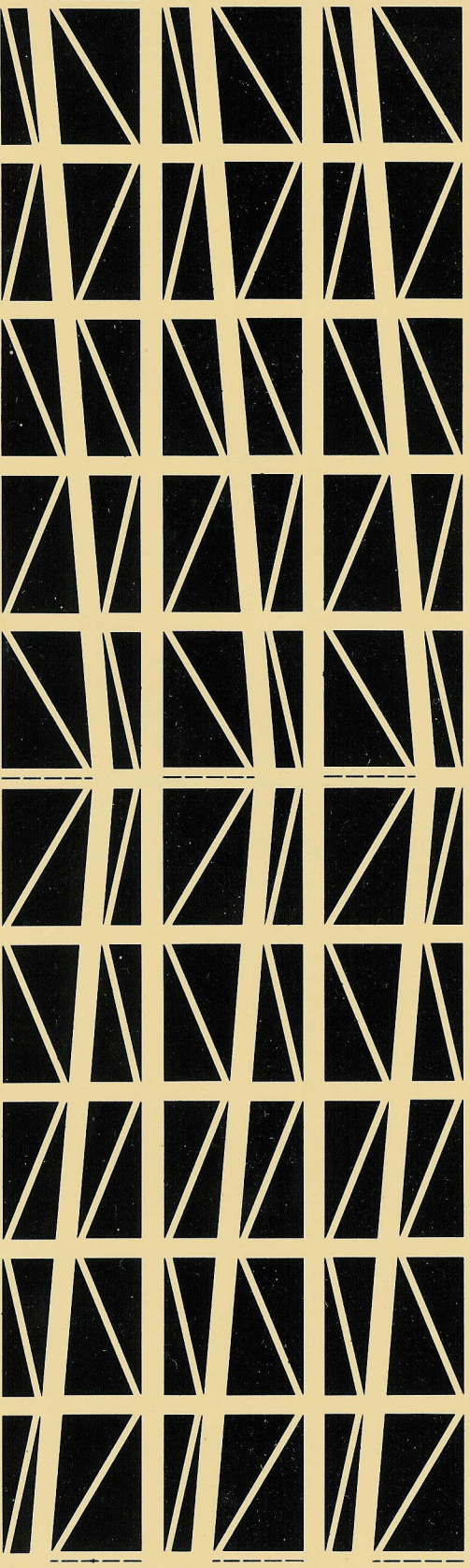

REFER TO ROCKET ASSEMBLY INSTRUCTIONS TO APPLY TRUSS DECALS.



12

12

ESTES INDUSTRIES

KD-97

PN 37102

SOLAR SAILER