

# Space Shuttle™

## FLYING MODEL ROCKET

### SKILL LEVEL 4

1—Beginner 2—Intermediate 3—Craftsman  
4—Advanced 5—Expert

Dramatic 1/162nd scale reproduction of America's newest space vehicle. Designed as a reusable near-space transportation system, NASA's Space Shuttle will be a multi-mission vehicle designed to perform such missions as the delivery and recovery of orbital payloads and space laboratory research. Our semi-scale orbiter employs glider recovery just like the real thing while boosters and external tank return via 18" parachute recovery. The model features special stabilizer fins for atmospheric flight which remove easily for display. Kit components include injection molded and vacuformed plastic and die-cut parts plus quick-release engine mount.

This is a hobby kit requiring assembly. Recommended for ages 10 to adult. Glue, paint, engines and launch system are not included with this kit.

#### Specifications:

Shuttle Length . . . . . 13.6" (34.5 cm)  
Diameter . . . . . 2.04" (51.8 mm)  
Orbiter Length . . . . . 9.0" (22.9 cm)  
Orbiter Wingspan . . . . . 7.1" (18.0 cm)  
Weight . . . . . 4.37 oz. (124 g)

Recommended Engine . . . . . C6-3



A SUBSIDIARY OF DAMON

ESTES INDUSTRIES  
PENROSE, COLO. 81240

#1284



Made in U.S.A.



# Space Shuttle

#1284



A DAMON COMPANY

**ESTES INDUSTRIES**  
 1295 H STREET  
 PENROSE, CO 81240 USA

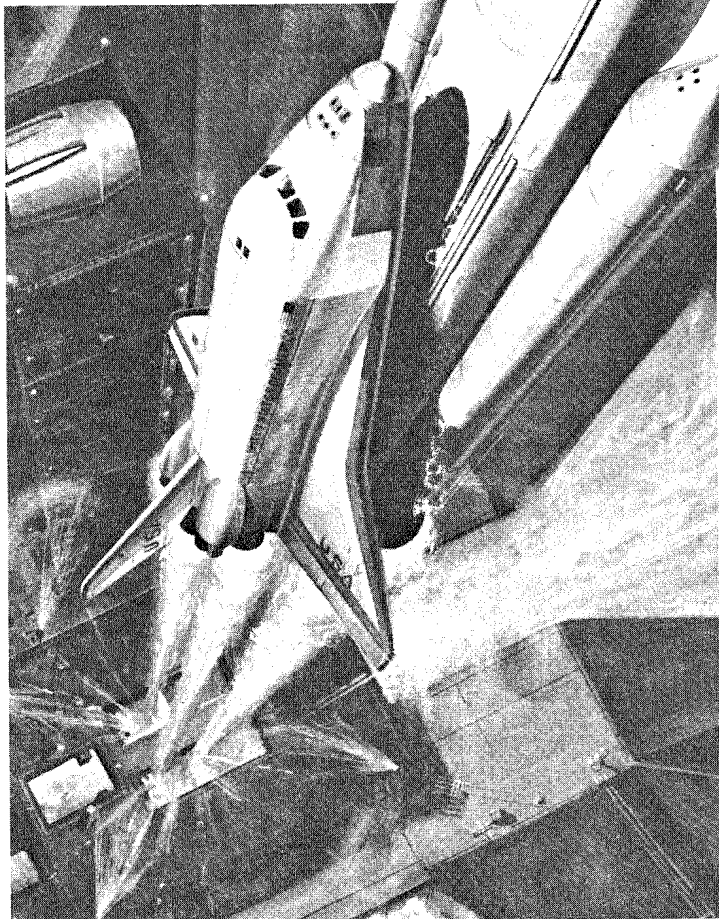

ET, SRB, OMS—Abbreviations like these tell the story of a transportation system for a new era in space. This is the age of the Space Shuttle, the system that gives America a true operational capability in space.

The key is the reusable Orbiter. This delta-winged, airliner-sized vehicle, flown by a crew of three, is designed to carry payloads—up to 65,000 pounds into orbit and up to 32,000 pounds from orbit to Earth.

The Orbiter is carried aloft by two 2.65 million pound thrust Solid Rocket Boosters (SRB) and its own three 375,000 pound thrust main engines which use propellant from the External Tank (ET). The SRB motors drop off after using up their fuel and parachute down for recovery and reuse. The main engines continue to burn until just before orbital velocity is reached. The ET is jettisoned to re-enter and burn up. The Orbiter's Orbital Maneuvering System (OMS) engines provide the needed kick to enter orbit. The OMS engines are fired again to slow the spacecraft for re-entry. Typical missions will remain in orbit for seven days, but longer missions are possible.

Re-entry is made into the atmosphere at a high angle of attack. At low altitude, the Orbiter goes into an aircraft-type approach and landing. The Orbiter is then towed to a hanger to be prepared for another flight.

Satellites, manned laboratories, telescopes and countless other scientific packages will be carried into orbit by the Shuttle. Coming back the Shuttle may bring a satellite needing repair, or its cargo may be super precision ball bearings, electronic components, or vaccines—products made possible only by space manufacturing techniques. The real payload from the Space Shuttle, though, will be knowledge—and a chance for a better life for Earth's people through that knowledge.

**MODEL NOTE:** Your Space Shuttle kit is a precision 1/162 scale model of America's manned launch vehicle for the 1980's. Because the "real" Space Shuttle employs complex electro-mechanical systems for guidance and stability, your model requires added fin area for safe flying. Auxiliary fin units are provided in the kit: **DO NOT ATTEMPT** to fly your model without the fin units or without the Orbiter (glider).

The booster portion of your model returns by parachute. When the parachute ejects the booster slows abruptly. This automatically releases the Orbiter for a glide return.

**SKILL LEVEL 4—This Kit is Recommended For Master Modelers**

## ASSEMBLY TIP

Read all instructions before beginning work on your model. Make sure you have all parts and supplies. Test-fit all parts together before applying any glue. If any parts don't fit properly, sand as required for precision assembly.

## PARTS AND SUPPLIES

Locate the parts shown on page 8 & 9 and lay them out on the table in front of you. In addition to the parts included in the kit you will also need:

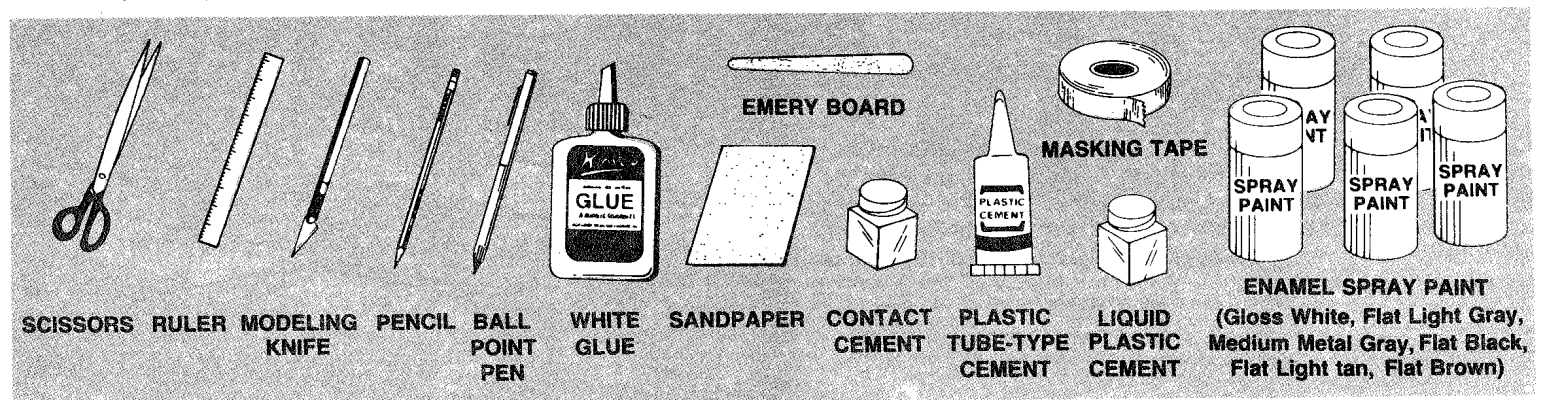

## IMPORTANT:

Read all instructions before beginning work on your Space Shuttle scale model. When you are thoroughly familiar with the way the model goes together, begin construction. Check off each step as you complete it. Pay extra attention to the three special instructions below:

A. Trim any "flash" or gate marks from the injection molded plastic parts. Wash all plastic parts in mild soapy water, rinse thoroughly and dry with a clean towel. Avoid unnecessary handling of the plastic parts after washing to keep dirt and skin oils from interfering with cement joints and paint finish.

## BOOSTER ASSEMBLY INSTRUCTIONS

1 Mark the engine mount tube (part E) 5/8" from one end. (This end will be the rear of the tube.) Cut out the engine mount marking guide from the pattern sheet (part F). Wrap it around the engine mount tube so the seam in the guide is next to the mark on the tube. Mark the tube at each arrow point. Draw a straight line connecting each matching front and rear mark. Extend the center line the entire length of the tube. Mark the center line 2-1/2" from the rear of the tube.

2 Cut a 1/8" long slit in the engine mount tube on the mark, 2-1/2" from the rear of the tube as shown. Insert one end of the engine hook (part G) into the slit and position the hook on the tube, centered between the hook guide marks. Hold the hook in place temporarily with a piece of masking tape near the rear.

3 Carefully separate the large rings from the large die-cut card (parts C1 and C2). Use a sharp knife to free the edges. Cut completely through the outer circle, exactly on the score line, next to the inner circle. Position and glue the ring with the engine hook cut-out (notch) so it is centered on the engine hook and is 1-5/16" from the rear of the engine mount tube. Position and glue the other ring 1/16" from the front of the engine mount tube so the alignment mark on the ring exactly matches the center line on the tube. Glue the retainer ring (part H) over the tube and against the rear ring as shown.

4 Cut out the fin tube marking guide from the pattern sheet. Wrap it around a fin tube (part I) at one end and mark the tube at each arrow point. (The marked end of the tube will be the rear.) Draw a straight line connecting each pair of matching marks. Mark the tube 2-1/4" from the opposite end. Repeat these steps for the other fin tube.

B. Test fit the parts together in each step before you apply any glue. In this way, should some part not fit perfectly, you can build up or sand down as appropriate for a precision fit and a perfect model.

C. Pay special attention to the type of glue, cement or adhesive called for in each step. Glue refers to white glue or aliphatic resin glue. Adhesive refers to the contact adhesive. Cement refers to styrene model plastic cement, both liquid and "tube-type" varieties. Make sure you use the exact material specified in each step.

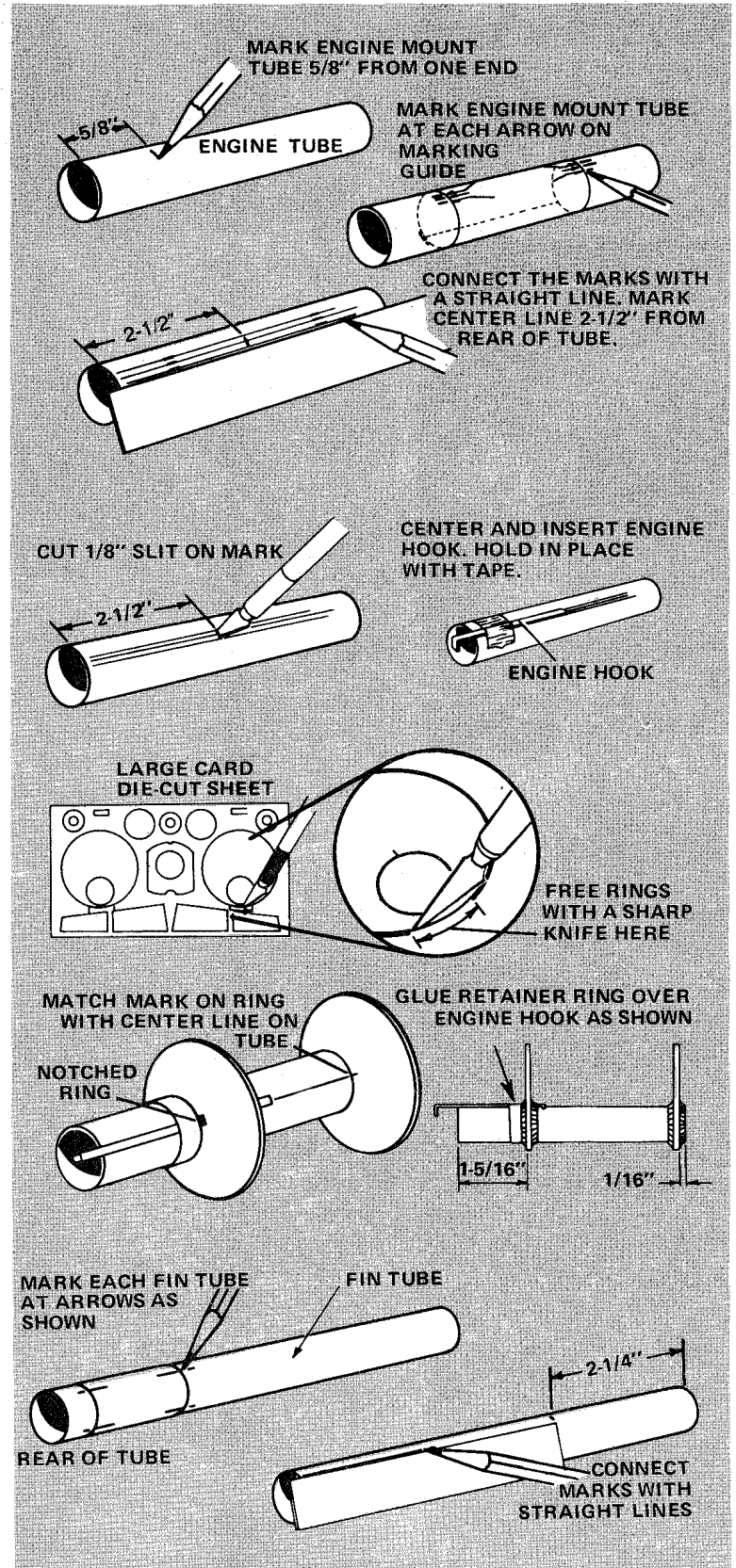

**5** Carefully separate the two cap discs (part C3) from the large die-cut card sheet. Glue one disc centered on the rear end of each fin tube. Glue a centering ring (part J) on each fin tube with the ring's rear on the mark, 2-1/4" from the front of the tube as shown. Glue the remaining centering rings on the fin tubes with their front edges even.

**6** Carefully cut out the fins from the pre-printed fin sheet (part K). Use an extra-sharp knife and a metal straight-edge to guide the knife. Make the cross-grain cuts first, then the outer edge cuts, and finally the angled cuts between fins. Use extra-fine sandpaper to round the leading (slanted) edge of each fin. Sand the other edges smooth and square. Smooth the sides of the fins.

**7** Glue the fins to the fin tubes using the lines drawn in step 4 as a guide. Apply glue to the root edge of each fin and rub the glue into the wood. Apply another line of glue to the root of each fin and position the fins on the fin tubes with the left edge of each fin next to the alignment line. The rear of each fin should be even with the rear of the cap disc. Check to be sure the fins project straight out from the tube and support the assemblies on their ends while the glue dries.

**8** Cut three pieces, each 3-1/8" long, from one 12" long X 1/12" diameter dowel (part L). Cut another 3-1/8" long piece from one end of another 1/12" dowel and save the rest of this dowel for use in step 35. Glue the dowel pieces to the rear edges of the fins and to the cap discs on the tubes as shown.

**9** Install the engine mount assembly in the ET body tube (part M) after first sanding away any burrs on the inside of the ET tube ends. Carefully slide the mount into one end of the tube until the rear mark on the engine mount tube is even with the end of the ET body tube (5/8" of the engine mount tube will project from the ET). Without disturbing the engine mount, apply a line of glue to cover the joint between the rear ring and the ET tube all the way around. Use one end of an uncut 1/12" dowel to help spread the glue. Apply glue to the joint between the front ring and the ET body in the same way and set the assembly on its front end while the glue dries.

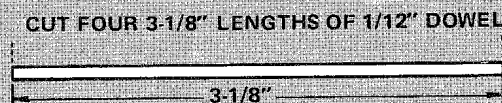
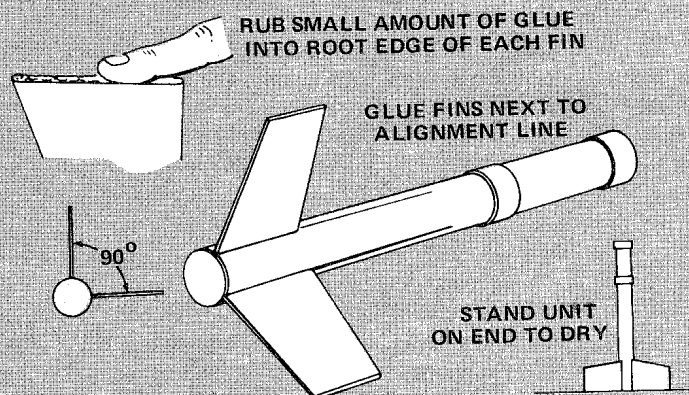
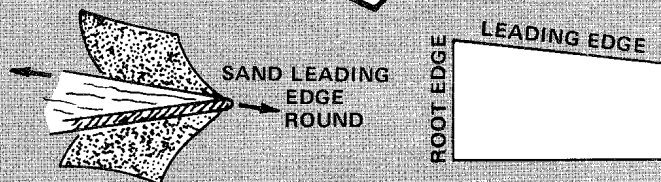
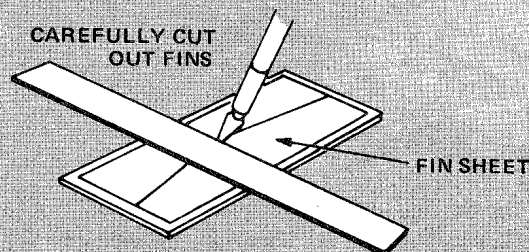
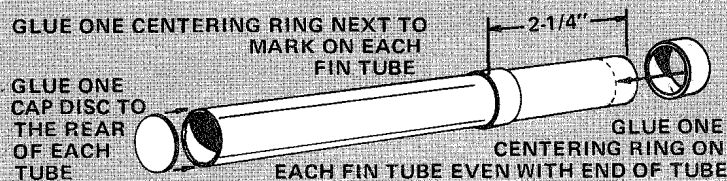

GLUE DOWELS TO REAR OF FINS AS SHOWN

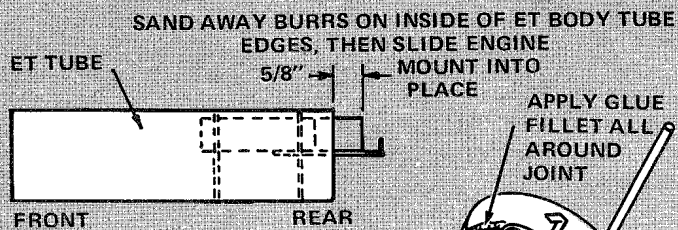



□ **10** Cut out the SRB tube marking guide from the pattern sheet. Wrap it around an SRB tube (part N), align the edges, and mark the tube at each arrow point, front and rear. Draw a straight line connecting each matching front and rear mark. Repeat step 10 for the other SRB tube.

□ **11** Apply a thin layer of tube type plastic cement around the last 1/8" of the outside of one end of each SRB tube. Locate the SRB aft skirt pieces (parts A1 and A2). Cement the skirt pieces to the coated ends of the SRB tubes. **IMPORTANT:** The conduit line end detail on each skirt must be centered exactly on one of the lines drawn in step 10.

□ **12** Separate the SRB rings from the small die-cut card (part O). Glue each ring to an SRB tube against the front of the skirt. For best results, first apply a very fine line of glue around the tube just ahead of the skirt, then slide the ring into place. Seat the ring squarely against the front of the skirt.

□ **13** Cut two 8-1/2" long pieces from the uncut 1/12" diameter dowels. Glue one dowel to each SRB tube, centered on the alignment line above the conduit end detail on the SRB skirt. The rear of each dowel should be against the card ring. Remove the SRB attachment bands (part D4) from the embossed card and glue them to the SRB tubes. Position each band so that its front edge is 2" from the SRB ring and its ends just touch the dowel. Bevel the front end of each dowel at a 45° angle as shown.

□ **14** Locate the separation motors (parts A3 and A4). Notice that one is marked "L" and the other "R" on the bottom. Find the SRB skirt marked "L" and write "left" on that tube in pencil. Use liquid plastic cement to attach the left separation motor to the skirt so the front of the separation motor is exactly on the position line on the skirt. Repeat with the right SRB assembly. **MASTER MODELER NOTE:** Sand lightly the mounting lugs on the separation motors using sandpaper wrapped on the SRB body for a precision fit.

□ **15** Temporarily install the ET base dome (part A5) on the rear of the ET tube. Position it so the engine mount tube is exactly centered in the rear opening. **DO NOT GLUE.** Mark the end of the ET tube exactly at the alignment marks on the sides of the base dome. Remove the dome.

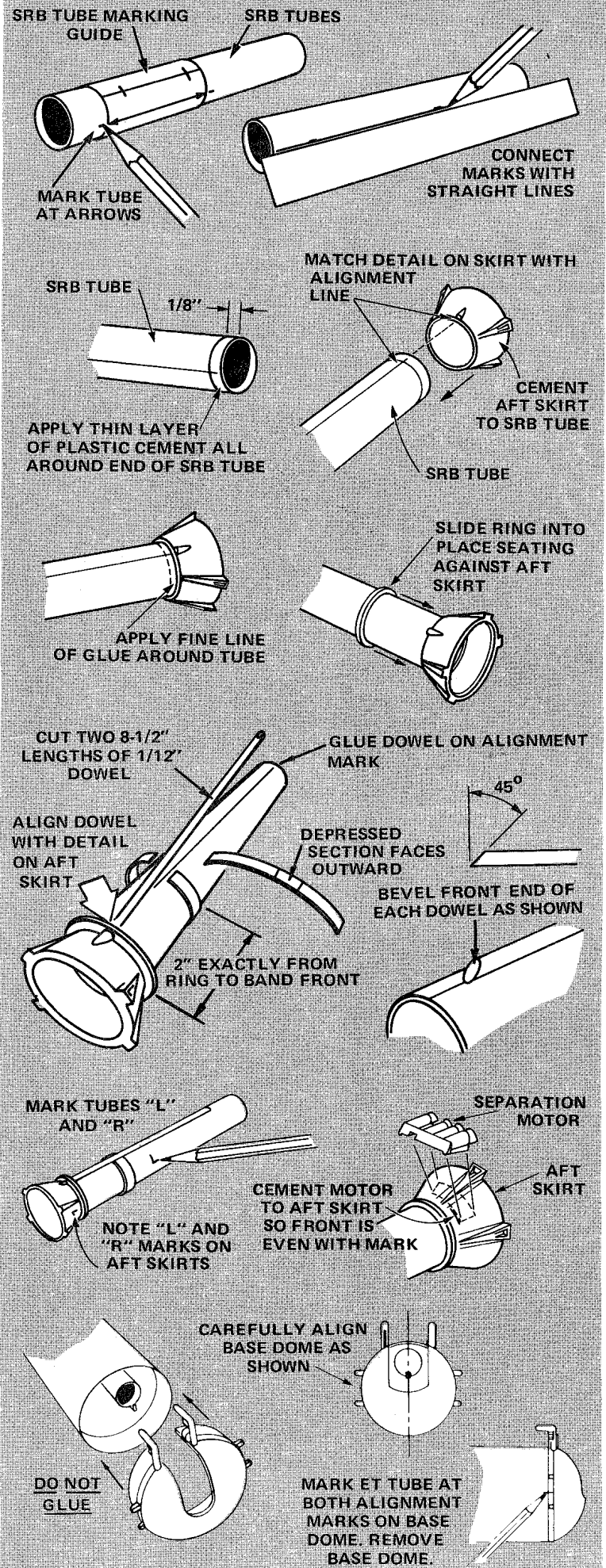



□ **16** Cut out the ET tube marking guide from the pattern sheet. Wrap it around the ET tube, matching precisely the SRB arrows with the marks made in step 15. Mark the tube at each arrow point, front and rear. Remove the guide and draw a straight line connecting each matching front and rear mark. Copy (in pencil) the identification of each line from the guide to the tube.

□ **17** Carefully separate the ET wrap (part D1) from the embossed card sheet. Use a sharp knife to free all edges including the two rectangular openings. Separate the rectangular detail stiffener (part D2) and glue it in place beneath the protruding ET detail as shown. Cut the border of the plastic fairing detail piece (part AA) to size as shown. Apply a line of plastic cement around the piece's border and press into place through the back of the ET wrap as illustrated. Cut a 7" length from one end of the shroud line cord (part P). Pass one end of the cord through the small hole in the ET wrap so that 1/4" protrudes from the back side. Apply a small drop of glue to the cord and press it down and forward, onto the back of the ET wrap as shown.

□ **18** Starting with one end of the ET wrap placed against the left SRB line on the ET body, position the wrap around the front of the ET body so the projecting line detail is even with the front of the tube. When the wrap is in exactly the correct position, mark all around its edges as shown, then remove the wrap.

□ **19** Apply a line of glue to the back of the ET wrap starting at the left SRB end and continuing for about 1" along the sides. Refer to the illustration. Be sure to keep the glue line about 1/8" in from the edges. Carefully position the edge of the wrap against the left SRB line and using the outline drawn in step 17 as a position guide, press the wrap into place. Hold the wrap in this position for about one minute until the glue sets. Then carefully apply two more short lengths of glue behind the ET wrap and press this portion into place. Repeat this procedure until the ET wrap is completely bonded all around the ET tube.

□ **20** Separate the ET lines detail piece (part D3) from the embossed card sheet. Apply a thin layer of glue to its back side. Notice the corresponding line detail on the ET wrap. Position the lines detail piece so it matches and extends the detail on the wrap and press it into place using the guide lines on the tube to be sure it is straight.

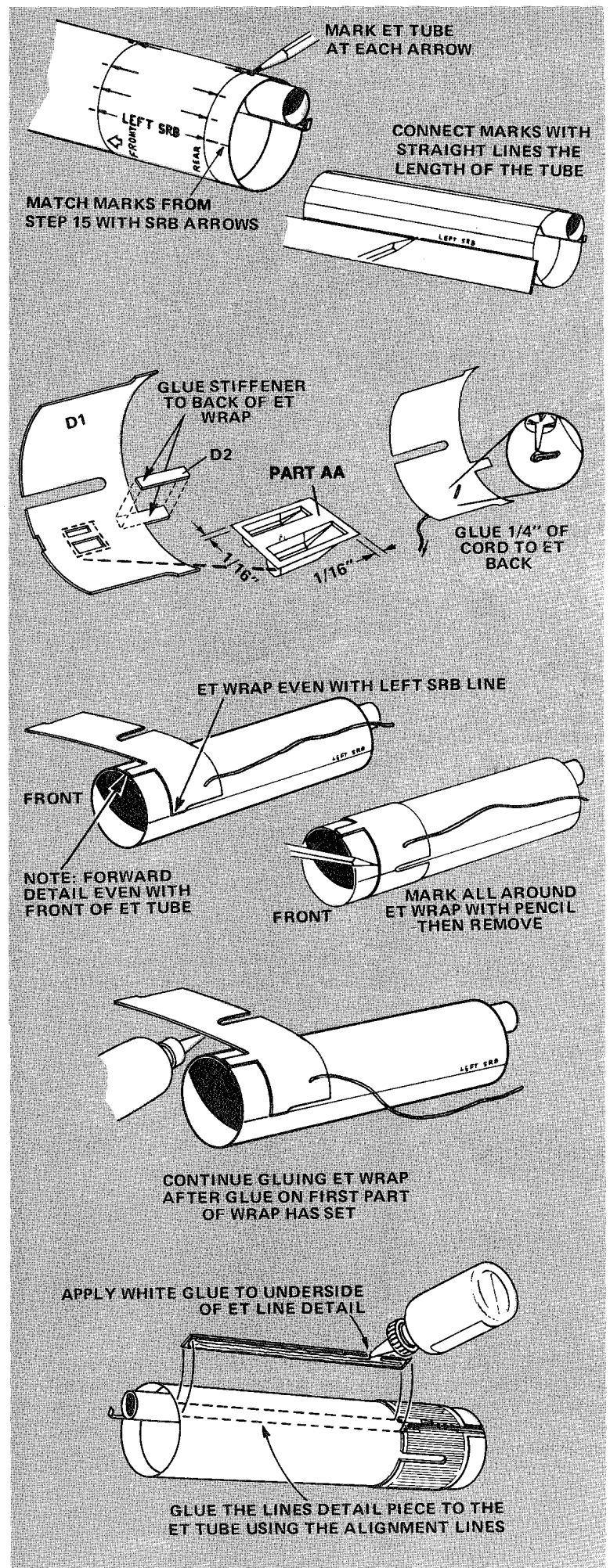



**21** Cut a 1/16" long slit in the rear end of the body tube at the pressurization line mark as shown. Pull the cord (attached to the ET wrap) tightly into the slit. (But don't pull so hard you pull the cord loose from the wrap.) Secure with glue. When glue is dry, cut off the excess line inside the body tube. **MASTER MODELER NOTE:** Clear butyrate dope, applied carefully with a very fine brush, will anchor the cord to the body tube and seal the cord so it takes paint well.

**22** Cement the ET base dome in place on the rear of the ET. First, smear a thin layer of tube-type plastic cement around the inside of the tube over an area extending 1/4" in. Carefully align the small SRB line marks on the dome with the SRB lines on the body and press the dome into place. (Note: Precise alignment is important.)

**23** Install the molded plastic Orbiter/ET fittings (parts A6 and A7). Notice that one is for the left side and the other for the right. Test-fit the parts, then use tube-type plastic cement to attach them to the ET base dome and the ET body as shown. Use the alignment lines on the body to be sure the flat plates on the fittings are straight on the body.

**24** Cut a 1-7/16" long piece from the 1/8" diameter dowel (part R) and save it for later use. Fit one end of the remaining dowel into the socket in the ET base dome. Mark the point on the dowel where it just reaches the rear of the oxygen feed line fitting on the ET wrap. Remove the dowel and cut it "square" at the mark. Glue the dowel in place.

**25** Glue the 1-7/16" long piece of dowel cut in step 24 to the stand-off piece (part R) as shown. Mark the center line on the ET body 4-3/8" from the rear of the tube. Glue the dowel/stand-off assembly to the ET body so the front of the stand-off is on the mark and the stand-off is centered on the line.

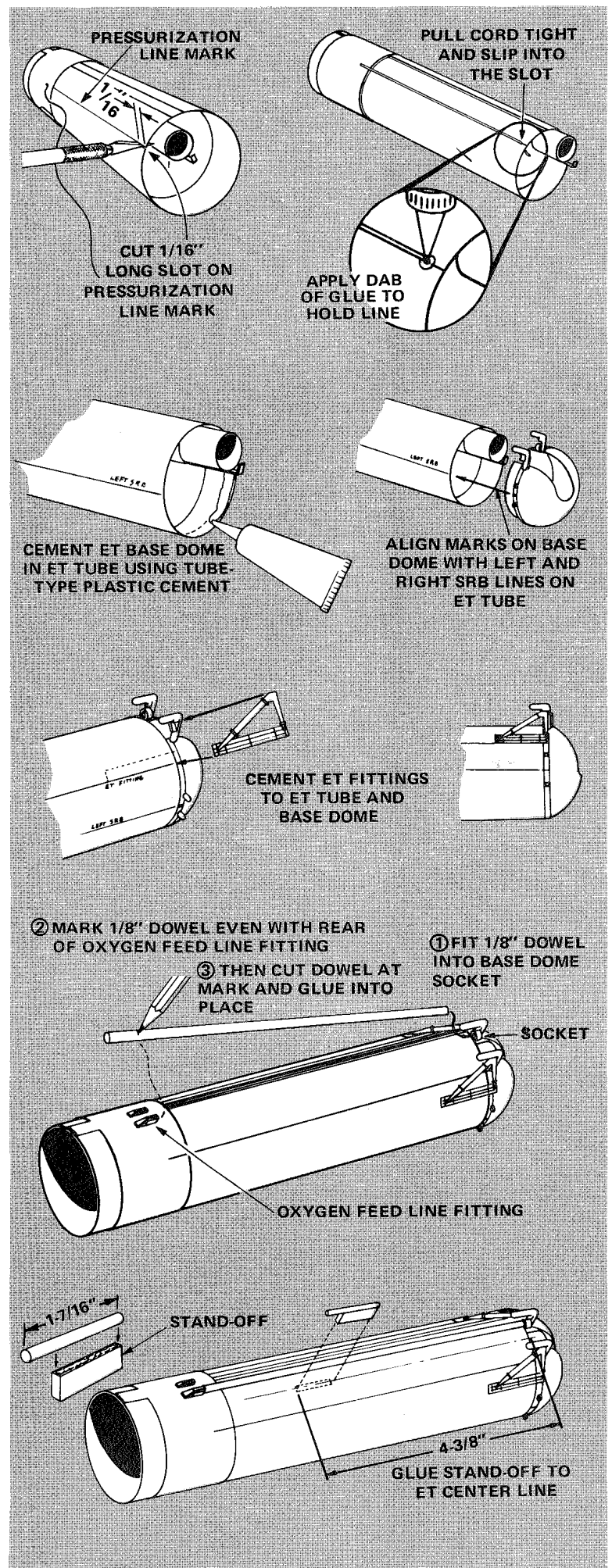



**26** Glue the two small launch lug spacers from the die-cut card to the ET tube next to the oxygen feed line. Glue one so that its front edge is 4-1/4" from the rear of the ET tube. Glue the other one so it is even with the rear of the ET tube. Glue two of the launch lugs (part S) **NEXT** to the launch lug guides as shown.

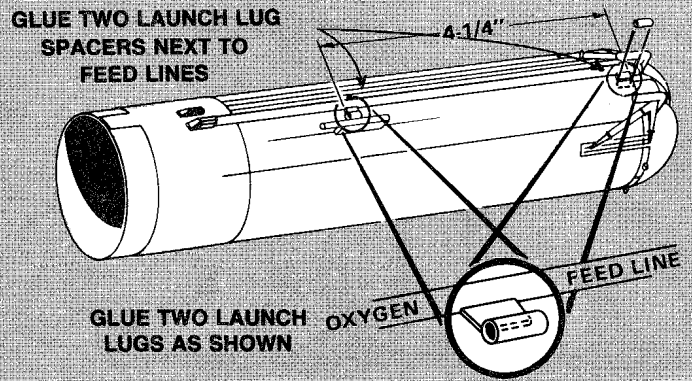

**27** Mark the SRB location lines on the ET body tube 1-1/8" behind the front of the ET body on both sides of the tube. Mark the inside of each SRB body at the front exactly in line with the unused guide line on the outside of the tube. Do this by marking the end of the tube first, then use this mark as a guide to mark the inside. Mark the inside of the ET body in line with the SRB location lines on both sides in the same way.

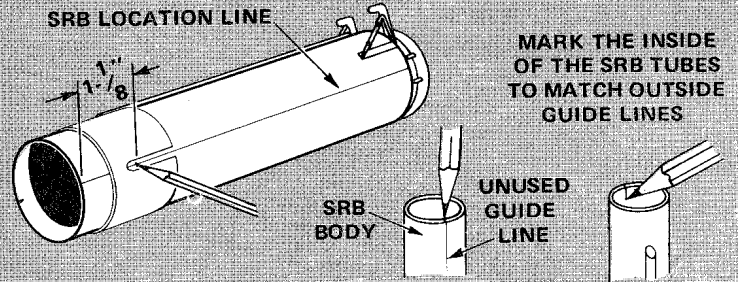

**28** Glue the SRB assemblies to the ET body. First apply a line of glue to the ET body along the left SRB position line from the mark (1-1/8" from the front) to the rear of the tube. Carefully position the left SRB assembly, starting with the front as illustrated. Holding the front in place, press the SRB into position so the alignment mark on the ET base dome matches the line on the SRB tube. Make certain that the alignment mark made inside of the SRB tube in step 27 is exactly in line with the SRB position line. Check alignment by sighting across the tops of the tubes as shown. Attach the right SRB in the same way. Set the assembly on its nose until the glue dries.

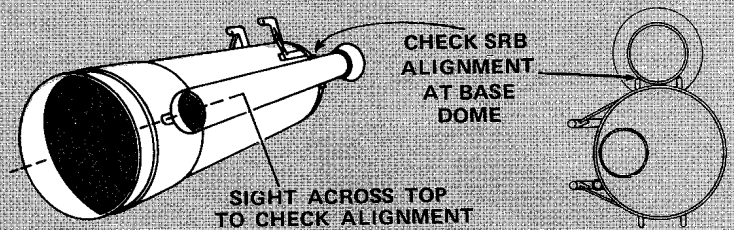
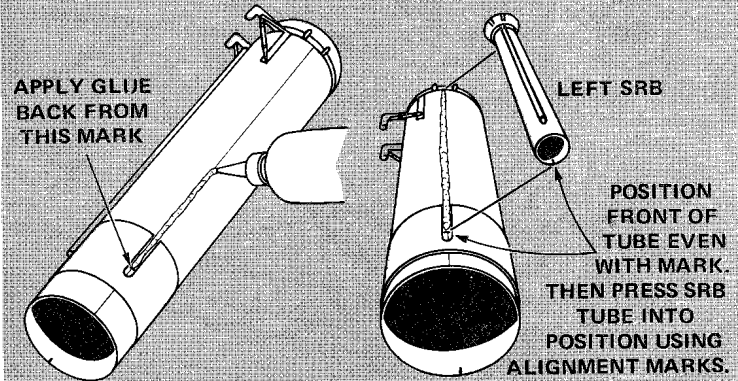

**29** Smear a thin layer of tube-type plastic cement around the inside of an SRB tube to cover an area extending 1/4" into the tube. Immediately insert an SRB nose cone (part A8) and press into place so the cone seats evenly in the end of the tube. Repeat with the other nose cone. Be careful to not disturb the alignment of the tubes.

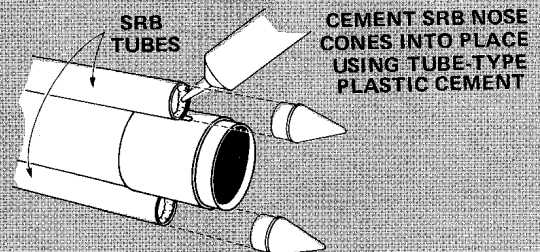

**30** Cut out the shock cord mount from the pattern sheet. Crease it on the dotted lines by folding. Spread glue on the first section (1) and lay the end of the shock cord (part T) into the glue. Fold over and apply glue to the back of the first section and the exposed part of section 2. Clamp the unit together with your fingers until the glue sets.

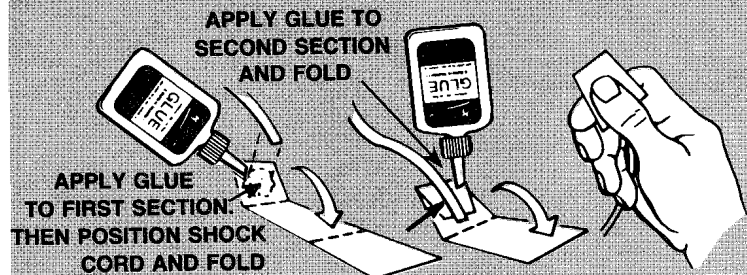

# space shuttle

KIT #1284

PARTS IDENTIFICATION  
AND OVERALL ASSEMBLY

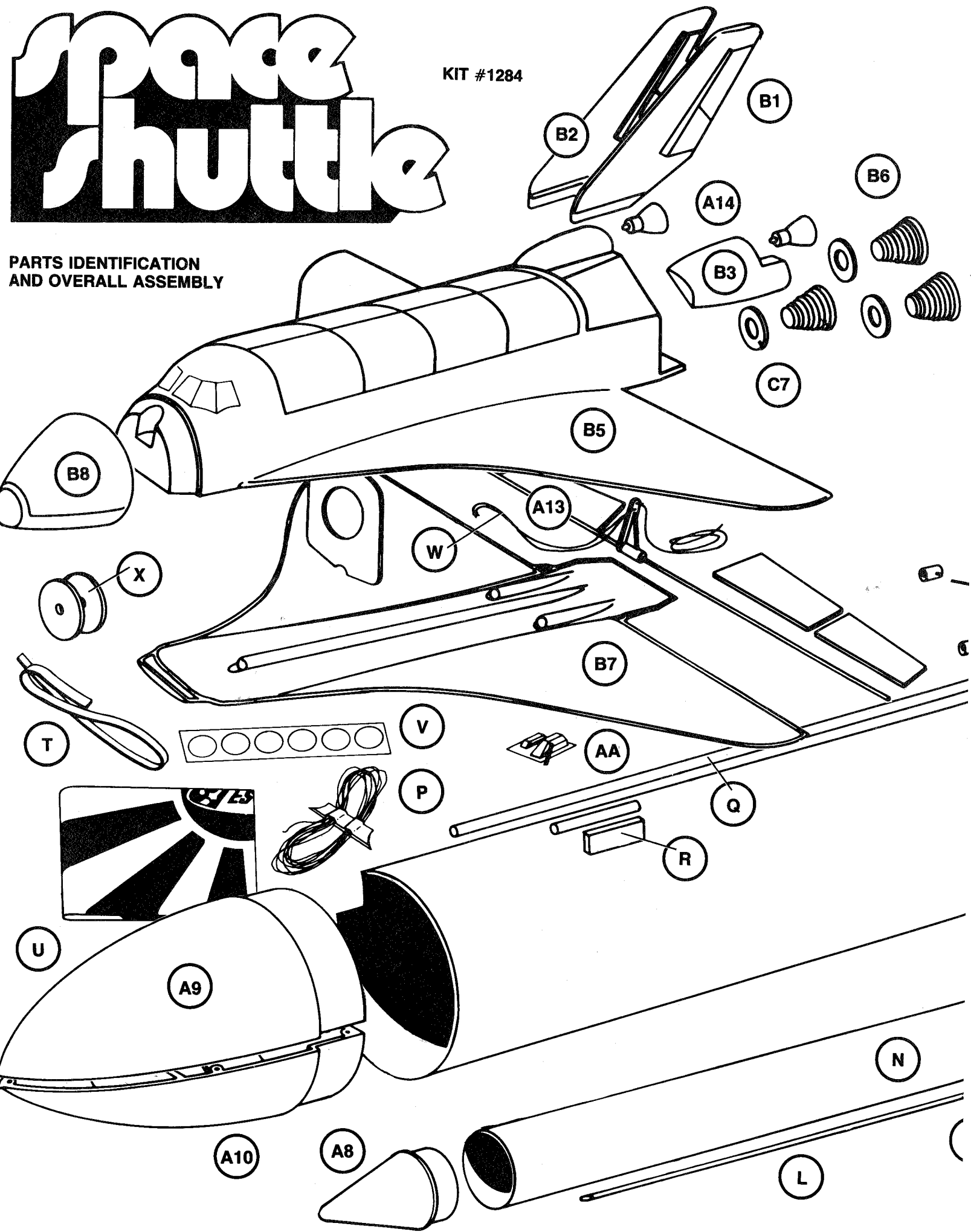



# PARTS IDENTIFICATION LIST

- A) 1 Injection-Molded Plastic Parts Set (type PRP-84)
- B) 1 Vacuum-Formed Plastic Orbiter Parts Set (type PF-84A)
- C) 1 Large Die-Cut Card Sheet (type TA-84A)
- D) 1 Embossed Card Parts Sheet (type PF-84B)
- E) 1 Engine Mount Tube (type BT-20DJ)
- F) 1 Pattern Sheet (type SP-84)
- G) 1 Engine Hook (type EH-2)
- H) 1 Retainer Ring (type HR-20)
- I) 2 Fin Unit Body Tubes (type ST-76)
- J) 4 Centering Rings (type CR-8)
- K) 1 Balsa Fin Sheet (type BF-84)
- L) 4 1/12" Diameter Dowels (type WD-2) 12" long
- M) 1 External Tank "ET" Body Tube (type BT-67GI)
- N) 2 "SRB" Body Tubes (type BT-46HI)
- O) 1 Small Die-Cut Card Sheet (type TA-84B)
- P) 1 144" Shroud Line Cord (type SLT-144)
- Q) 1 1/8" Diameter Dowel (type WD-1S) 9" long
- R) 1 Hardwood Stand-Off Piece (type HS-84)
- S) 5 Launch Lugs (type LL-2AM)
- T) 1 Shock Cord (type SC-2MJ)
- U) 1 Parachute (type PK-18A)
- V) 6 Tape Discs (type TD-3F)
- W) 1 12" Elastic Thread (type ET-1J)
- X) 2 Balance Weights (type NCW-1A)
- Y) 1 Pre-Printed, Elevon Hinge Sheet (type KD-84B)
- Z) 1 Decal (type KD-84A)
- AA) 1 Fairing Detail Piece (type PF-84C)

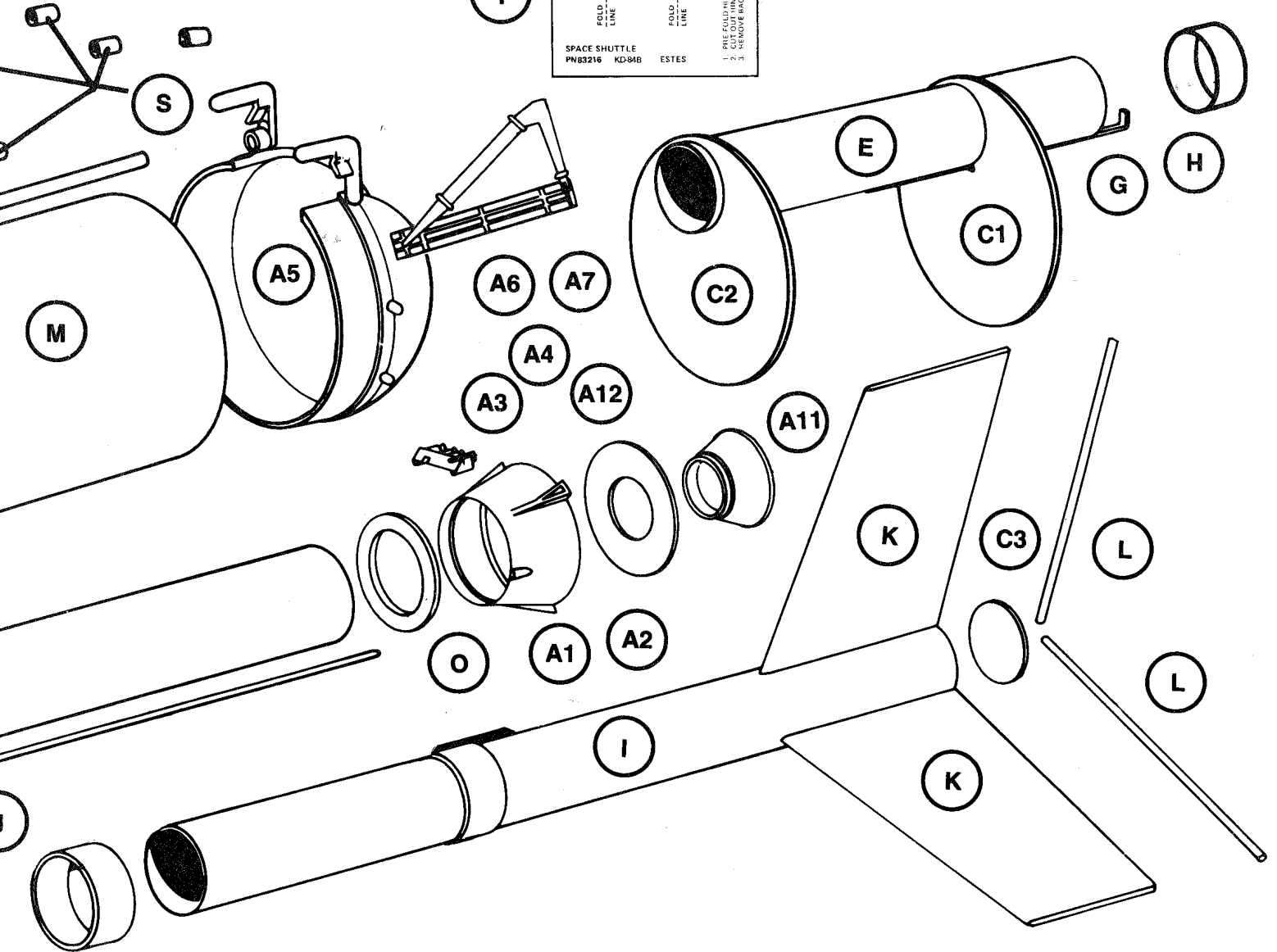
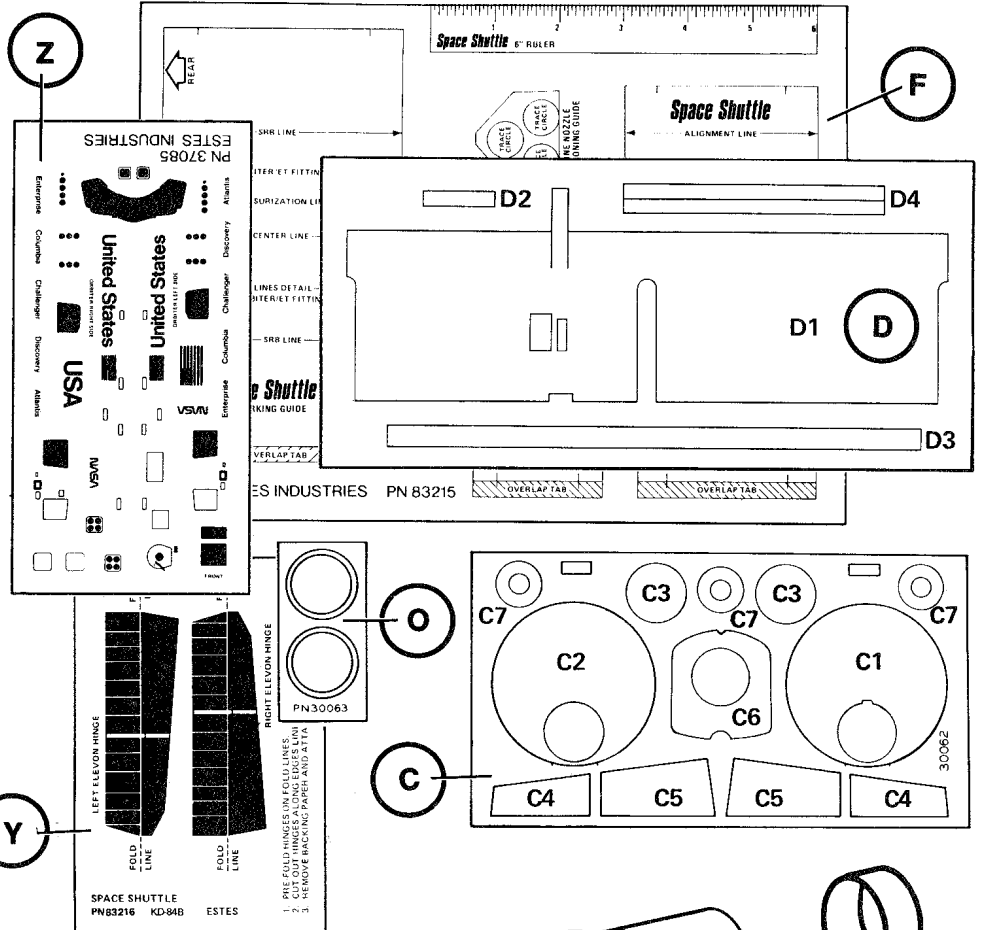

**31** Apply glue to the inside of the ET body tube at the front over an area about 1" to 2" from the end. The glued area should be the same size as the shock cord mount. Press the mount into the glue as shown and hold it until the glue sets.

**32** Using liquid plastic cement, join the two halves of the ET nose cone (parts A9 and A10). Apply the cement carefully so none will show on the outside of the part. Fit the parts together so the pins on the one half fit into the holes in the other half. Tape the halves together while the cement dries.

**33** Cut out the parachute (part U) on its edge lines. Cut three 35" lengths of shroud line (part P). Attach line ends to the top of the parachute with tape discs (part V) as shown. Pass the shroud line loops through the ring on the nose cone. Pass the parachute through the loop ends and draw the lines tight against the ring. Set the knot with a drop of glue. Tie the free end of the shock cord to the nose cone. (Save the unused shroud line for step 37.)

**34** Using liquid plastic cement, join a dummy nozzle (part A11) to a thermal curtain ring (part A12). The nozzle plugs into the contoured side of the thermal curtain. Repeat with the other ring and nozzle. When the cement on these assemblies is dry they can be snapped into place in the rear of the SRB skirts for display. For flight you will remove them and install the fin assemblies in their place.

## ORBITER ASSEMBLY INSTRUCTIONS

**35** Cut a 7-3/16" long section from the small (1/12" diameter) dowel saved from step 8. Slide the plastic elevon horn (part A13) onto one end of the dowel. The horn should fit snugly on the dowel. If the fit is too tight so the horn won't slide along the dowel, sand the dowel with fine sandpaper for a proper fit. Measure 3-19/32" from one end and mark the dowel (at its center). Apply a line of tube-type plastic cement around the dowel at the mark. Slide the horn along the dowel and onto the cement. Center the horn over the mark on the dowel.

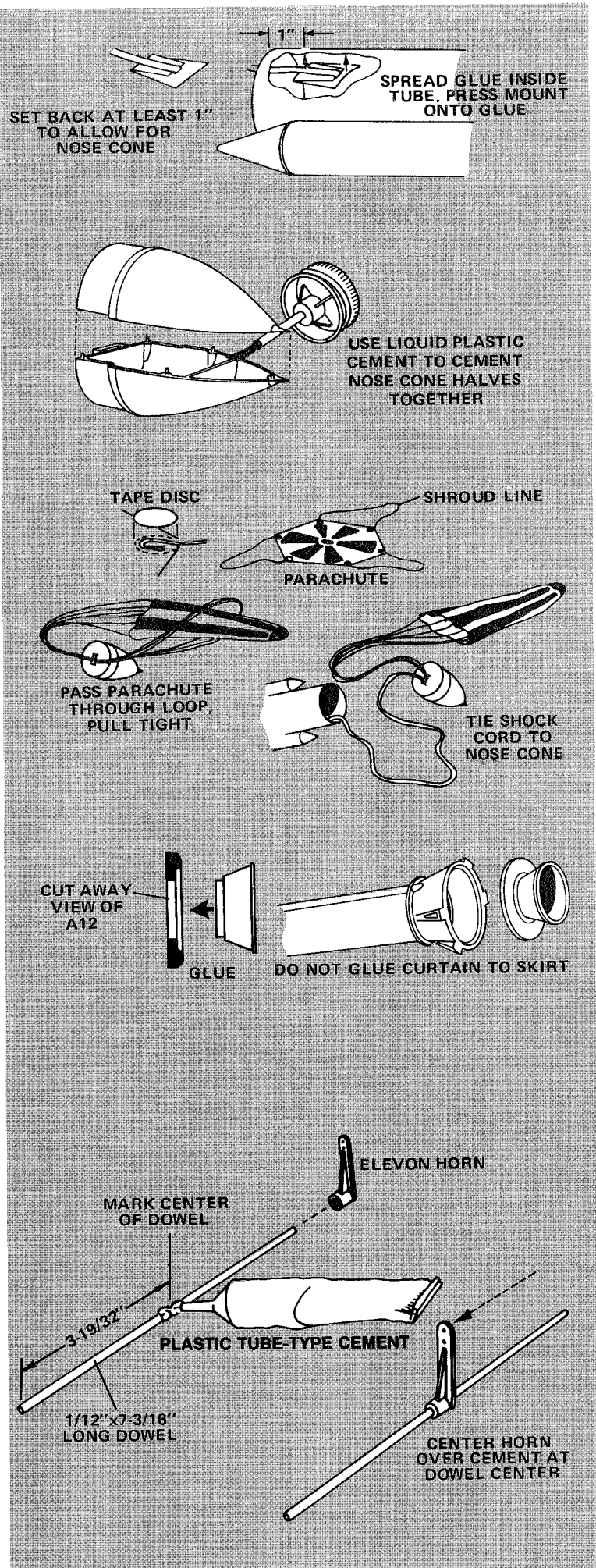



**36** Lay the elevon horn/dowel assembly on its side on a flat working surface. Remove one small die-cut elevon section (part C4) from the die-cut card sheet. Apply a line of glue along the edge illustrated. Attach the elevon section to the dowel, exactly even with the end as shown above. The elevon section should project straight up from your working surface. Carefully wipe away any excess glue. Hold the elevon section in place until the glue "sets".

Remove the next larger elevon section (part C5) from the card. Apply glue to the edge shown. Glue this piece to the dowel, 1/16" away from the smaller section. **IMPORTANT: BOTH ELEVON SECTIONS MUST BE EXACTLY IN LINE WITH EACH OTHER.** Hold the section in place until the glue sets. Follow the same procedure to glue the two remaining elevon sections to the other end of the dowel assembly. **ALL ELEVON SECTIONS MUST BE EXACTLY IN LINE WITH EACH OTHER.** Check alignment during assembly with the edge of a ruler.

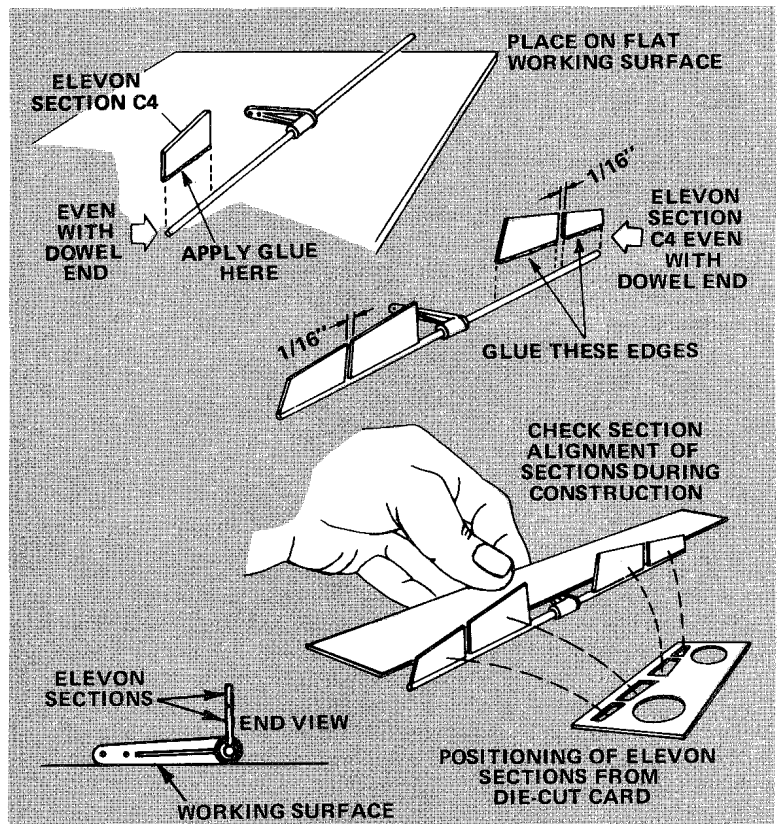

**37** Cut a 10" length of shroud line from the remaining shroud line cord. Pass one end of the line through the hole at the very end of the elevon horn. Tie a double knot. Apply a dab of glue to hold the knot. Cut a 10" length from the elastic thread (part W). Pass one end of the elastic thread through the other horn hole. Tie the free ends of the elastic thread together in a double knot. Set the elevon assembly aside to dry completely.

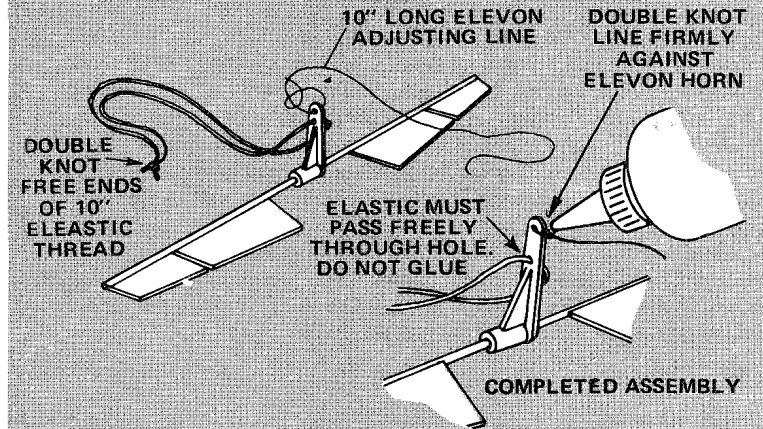

**ORBITER PARTS SHEET**

**CUT THROUGH PLASTIC "BRIDGES" BEFORE REMOVING PARTS**

**NOTE:** To insure good cement joints, wash the plastic orbiter parts as directed in pre-assembly step A. Do not attempt to pull the plastic parts directly from the sheet when separating them. Use a modeling knife to cut through each small plastic "finger" or bridge holding the part. This prevents accidentally tearing the plastic parts.

**38** Remove the two vertical stabilizer halves (parts B1 and B2) from the orbiter parts sheet. Apply a line of liquid plastic cement around the inside edge of one stabilizer half. Join the two halves and align carefully. Be sure that both body edges are even and parallel. Hold the halves together with short strips of masking tape as required until the assembly is dry.

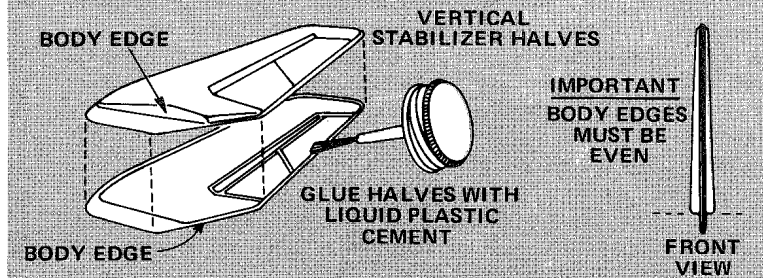

**39** Remove both OMS shroud pieces (parts B3 and B4) from the plastic sheet. Carefully sand away the excess plastic flange surrounding the shrouds. Sand the front edge of each shroud piece until it is flat. Mark the rear of each OMS shroud as shown. Drill a hole at each mark just large enough for the pin on the plastic OMS nozzle (part A14) to fit through. Use plastic cement to attach one nozzle to each shroud piece. Place the assembled units on a flat surface until the cement is dry.

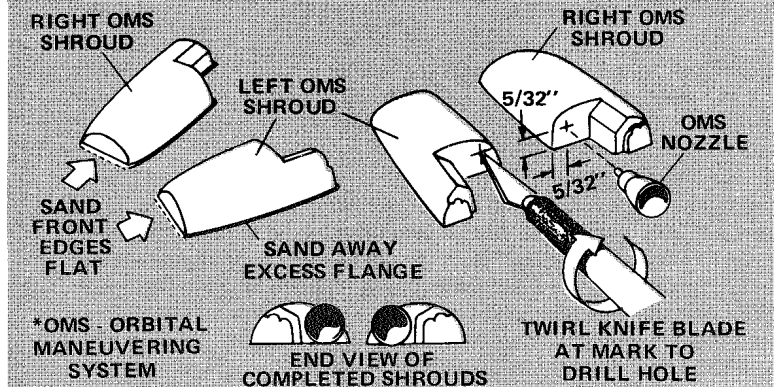

**40** Remove the fuselage top (part B5) from the Orbiter parts sheet. Sand away the web of plastic material located at the joint between the wing trailing edge and fuselage body, on both sides of the fuselage. An emery board or suitable modeling file is recommended. The wing trailing edge should meet the body side squarely. Carefully continue sanding until you have shaped a half-round notch in both sides of the fuselage body edge. The notch should be approximately  $3/32''$  wide,  $1/16''$  deep, and just rearward of the wing trailing edge.

**41** Cut out the engine nozzle positioning guide from the pattern sheet. Rub the backside of the guide with a soft pencil lead. Place the guide against the fuselage bulkhead (pre-printed side facing out) as shown. Hold the guide in place and firmly trace the three nozzle locating circles. Remove the guide and apply tube-type plastic cement to the flat side of one die-cut nozzle ring. Cement the ring to the fuselage bulkhead, centering it on one of the traced circles. Cement the remaining nozzle rings into place on the fuselage bulkhead.

**42** Remove the three engine nozzles (part B6) from the Orbiter parts sheet. Sand away any excess plastic flange from around the large nozzle openings. Using scissors or a modeling knife, cut a  $1/8''$  long slit into one of the nozzles as illustrated. Do this to one nozzle only. Smear tube-type plastic cement onto the exposed plastic in the center of the nozzle ring located at the top of the fuselage. Press the small end of the nozzle with the  $1/8''$  slit into the ring center until it seats firmly against the bulkhead. Position the  $1/8''$  slit at the top of the model, in line with the center of the fuselage body. Cement the remaining nozzles to the bulkhead in the same manner. All nozzles should project straight away from the fuselage bulkhead.

**43** Sand away any excess flange from the seam of the vertical stabilizer. DO NOT remove the large flange from the body edge. Cut a slit into the fuselage groove at the rear of the body. Center the slit as best as you can along the entire groove length. Test fit the stabilizer into the groove slit. The stabilizer body edges should seat firmly against the top of the fuselage. Apply liquid type plastic cement to the stabilizer body edges and press the stabilizer into place. IMPORTANT: The stabilizer must project straight up from the fuselage body and be directly in line with the detail line running along the top of the fuselage. Incorrect stabilizer alignment may cause excessive right or left turn during the model's glide return.

**44** Apply liquid type plastic cement to the front edge of the left OMS shroud (part B3). Also brush cement along those portions of the bottom edge which will contact the sloped surface at the rear of the fuselage. Seat the front of the OMS shroud squarely against the fuselage stop on the left-hand side of the body. Center the sides of the OMS shroud on the sloped fuselage surface. Additional liquid cement may be carefully brushed into the shroud/fuselage joint if necessary to hold the shroud securely. Cement the right OMS shroud (part B4) assembly to the right side of the fuselage in the same manner. Be careful to avoid accidentally reversing the left and right hand shroud positions. The small plastic OMS nozzles should be next to the vertical stabilizer. Refer to the rear view illustration.

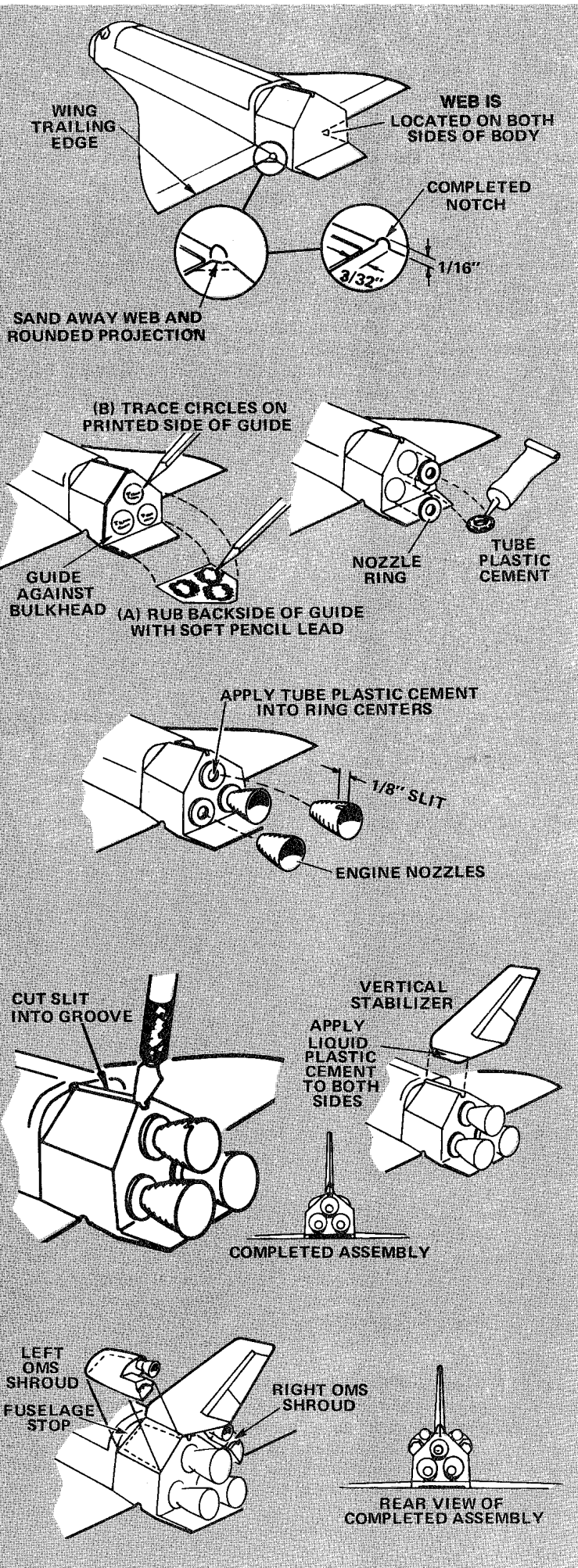



□ **45** Drill a 3/16" diameter hole through the fuselage bulkhead in the center of the top engine nozzle. Remove the forward fuselage bulkhead from the large die-cut card sheet and discard the center disc. Apply tube-type plastic cement to the rounded edge and straight sides. Insert the bulkhead squarely into the body as shown, approximately 2-1/4" from the front of the fuselage. Press the bulkhead into place firmly against the fuselage top. Squeeze the fuselage sides against the bulkhead until the plastic cement "sets".

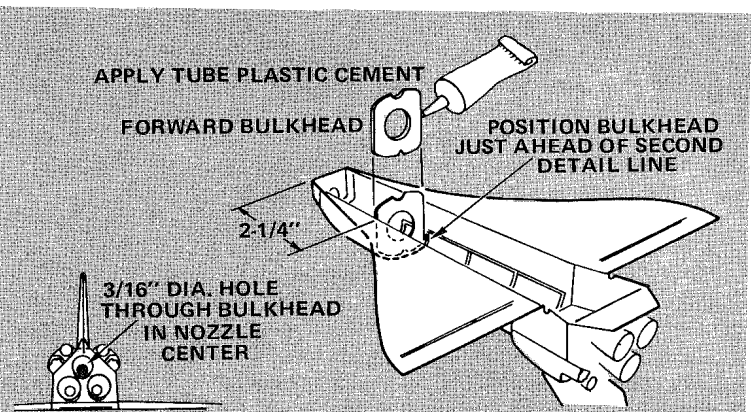

□ **46** Drill a 1/32" diameter hole into the dimple at the front of the fuselage. Place the elevon assembly into the fuselage body as shown. Pass the knotted end of the elastic thread loop through the forward bulkhead opening and then through the tiny hole in the dimple. Make certain that the knot is pulled into the nose dimple. Apply a drop of white glue to the knot to hold it. Pass the free end of the shroud line thread through the opening in the rear body bulkhead.

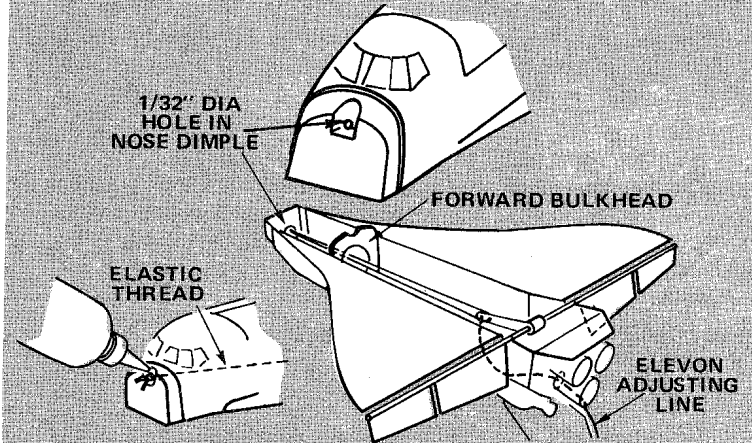

□ **47** Remove the fuselage bottom (part B7) from the Orbiter parts sheet. Sand away the web of plastic material located at the joint of the wing trailing edge and fuselage body on both sides of the fuselage. Follow the same procedure as in step 40 to shape a half-round notch in each side of the fuselage as shown. The notch should be approximately 3/32" wide, 1/16" deep and just rearward of the wing trailing edge.

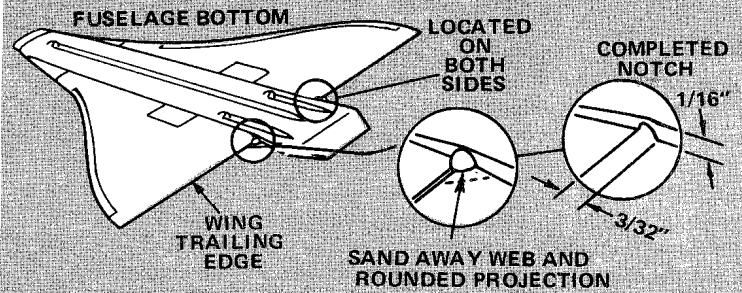

□ **48** Carefully align both Orbiter body halves. Use masking tape to hold both wingtips, nose and tail section together as illustrated. Check to be sure that all body half edges meet evenly. The elevon dowel must be able to move freely in the fuselage notches. If necessary, enlarge the notches.

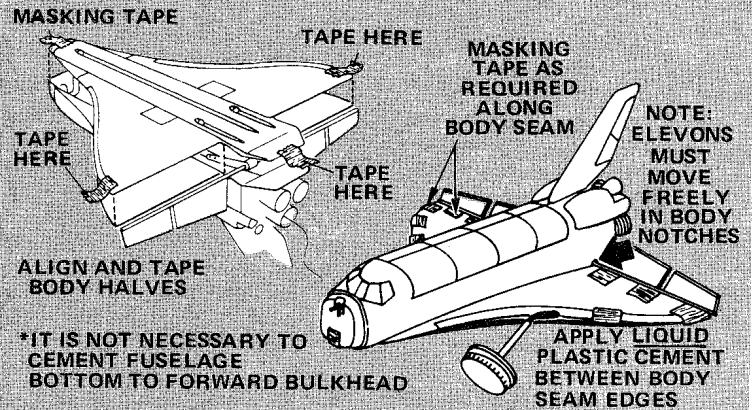

Beginning at one wingtip, brush liquid plastic cement onto both body seam edges and press them together. Apply cement along the body seam for a distance of 2 or 3 inches at a time. Use short strips of masking tape to hold the glued edges together. Continue cementing in short sections until you have completed the entire Orbiter body seam. Be careful to avoid getting any cement on the elevon dowel.

□ **49** Apply contact adhesive cement along the sides and bottom of the three lug grooves. Cover an area extending 3/8" rearward from the raised lug stops. Position each remaining launch lug (part S) against a raised lug stop as shown and press it firmly into the adhesive. Spread a light coat of white glue over the exposed portions of the lugs to protect them from landing damage.

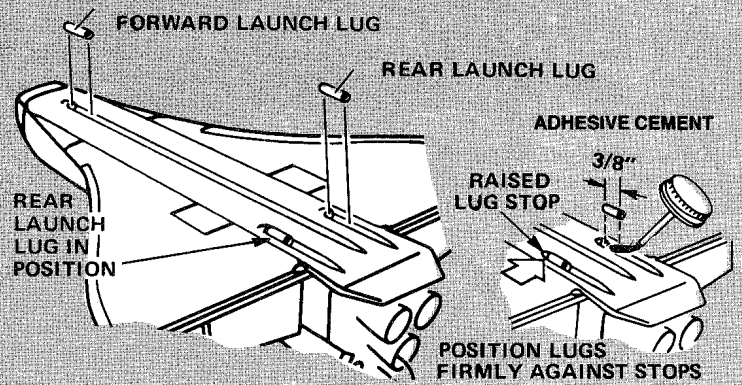

□ **50** Using a ball point pen, draw a straight, heavy line around the base edge of the Orbiter nose cap (part B8). Remove the nose cap from the parts sheet. Holding the nose cap as shown, use an emery board or sanding block to remove the base edge flange. Sand back and forth across the base edge until the flange breaks cleanly away. Do not sand into the nose cap beyond the ball point pen line.

□ **51** Sand away the excess shoulder seam at the Orbiter nose. Test fit the nose cap onto the Orbiter. The sides of the nose cap should fit even with the matching sides of the Orbiter nose. Sand the nose cap edge as required until it fits evenly and squarely against the nose shoulder stop. Place one and one-fourth balance weights (part X) into the very tip end of the nose cap. Balance weights can easily be cut with heavy-duty scissors. Pack 1 or 2 squares of parachute recovery wadding or cotton into the rest of the nose cap to hold the balance weights as far forward as possible. Temporarily tape the nose cap into place.

□ **52** Hold the Orbiter in one hand and pull the elevon shroud line rearward. Notice the movement of the elevon assembly as you do this. Pull the line rearward until the elevon sections are level with the wings. Slip the elevon line into the nozzle notch to hold it. Cut off the excess line 3" from the notch.

**Note: Finish and paint the Shuttle Orbiter as shown on page 15 before proceeding to step 53.**

□ **53** Lightly mark the Orbiter top with pencil, 2-11/16" rearward from the forward cargo door detail line. Tape a length of string exactly on the mark as shown. Suspend the model from a suitable stationary object. (For best results, do not hand-hold the string.) When the model is hanging motionless it should be perfectly level for correct balance position. If the Orbiter hangs with its nose slightly downwards, remove a small amount of balance weight from the nose cap. If the model hangs slightly nose upwards, add more balance weight to the nose cap. When you have completed balancing your model and it hangs perfectly level, use liquid plastic cement to permanently attach the nose cap.

## FLIGHT TRIMMING

Your Space Shuttle Orbiter model is designed to glide correctly the first time if it is balanced and trimmed according to the instructions. For best results, however, watch the Orbiter carefully on each flight as it descends after separation from the booster.

The Orbiter relies on the position of the elevon to make it glide. If the elevon is set too high, the glider will "stall" in flight (see illustrations). If the elevon is set too low the model will fly too steeply and too fast. Careful adjustments to prevent either of these are important. For your first Shuttle launch, adjust the elevon angle so that the trailing edge of elevon section C5 is 3/16" above the body seam line as shown.

To change the angle of the elevon, pull the string loose from the nozzle, raise or lower the elevon as necessary, and re-insert the string in the nozzle. **IMPORTANT:** Lowering the elevon corrects stalling while raising the elevon corrects diving. **NEVER** change the elevon angle more than 3 degrees at a time while trimming for proper glide. More trimming could over-correct the problem and make the Orbiter fly poorly.

If the Orbiter turns too sharply, forming a steep spiral turn, one of the elevons may be positioned higher than the other. A sharp left turn is caused by the left elevon (viewed from the rear) being higher than the right. A sharp right turn is caused by the right elevon being higher than the left. Correct this by grasping the elevons and twisting them GENTLY until the elevons are straight and even. If the tight turn persists, twist the assembly even farther. Also check to be sure the vertical fin is straight. A gentle right or left turn is desired in order to keep the Orbiter within the recovery area. Following each final flight, pull the elevon string loose from the nozzle to relax the elastic thread.

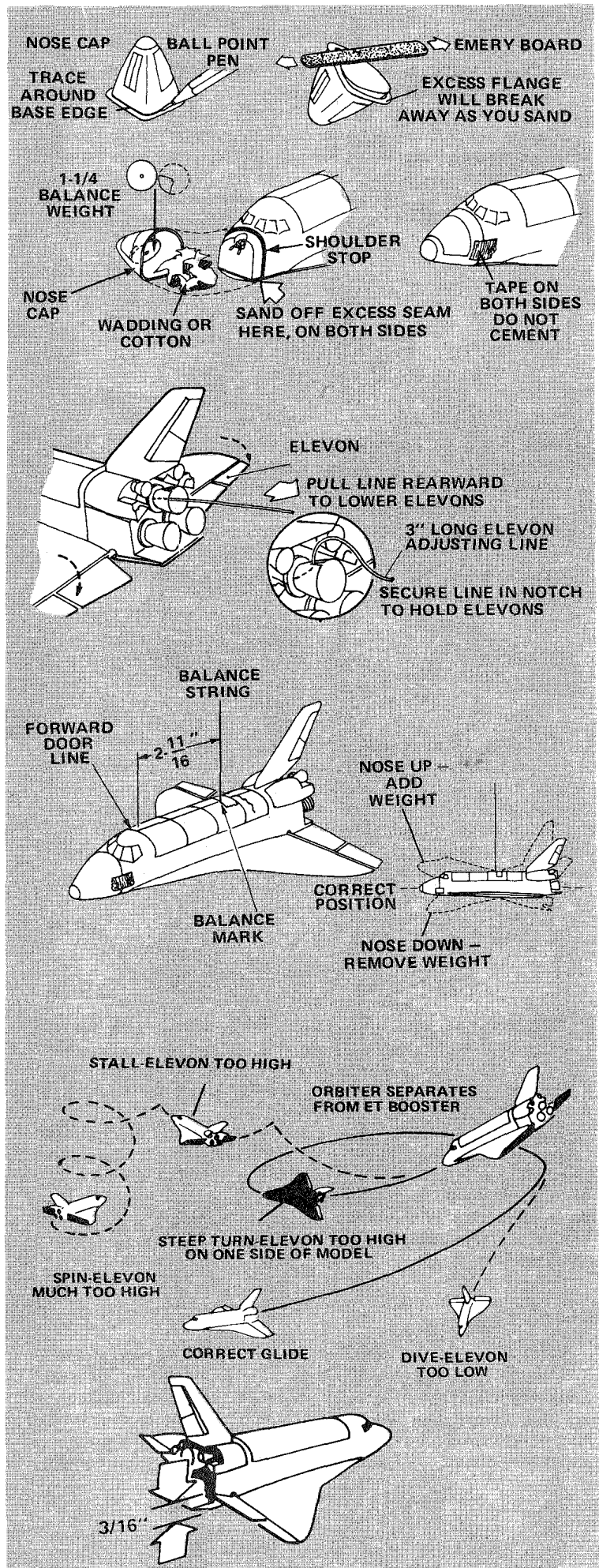



# NOTE

This kit includes accurate NASA Space Shuttle markings as of July, 1979. Refer to this sheet for all painting instructions and decal placement. You also have your choice of orbiter name decals: *Enterprise* (Orbiter 101), *Columbia* (Orbiter 102), *Challenger* (Orbiter 099), *Discovery* (Orbiter 103), and *Atlantis* (Orbiter 104). Orbiter *Columbia* was the first shuttle to be launched into Earth orbit in April 1981.

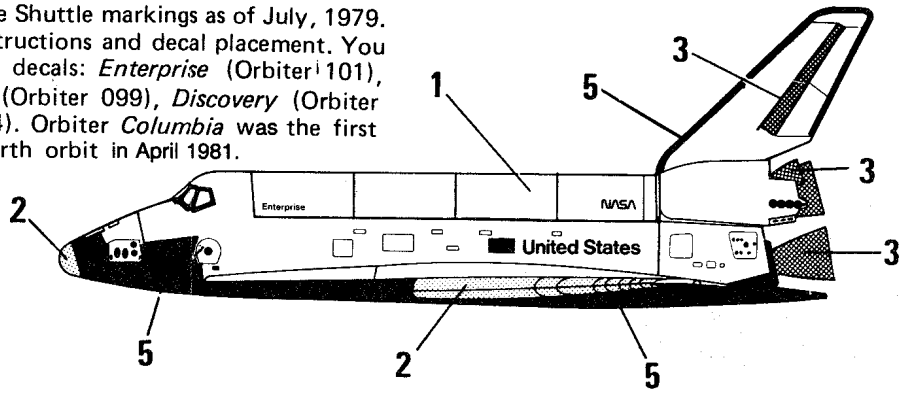
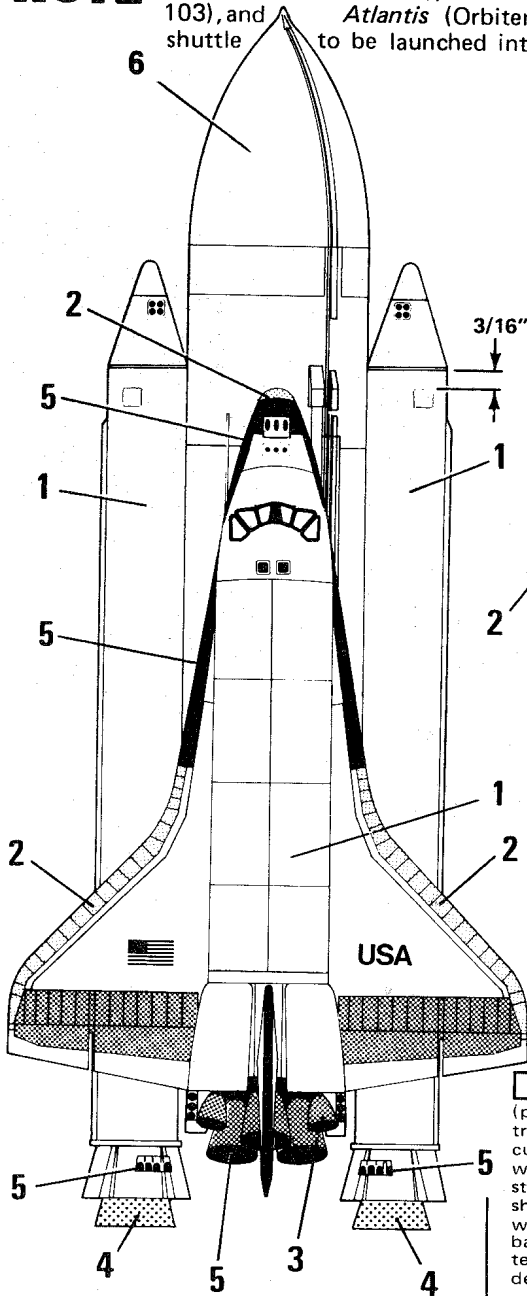

Choose one pair of Orbiter name decals:

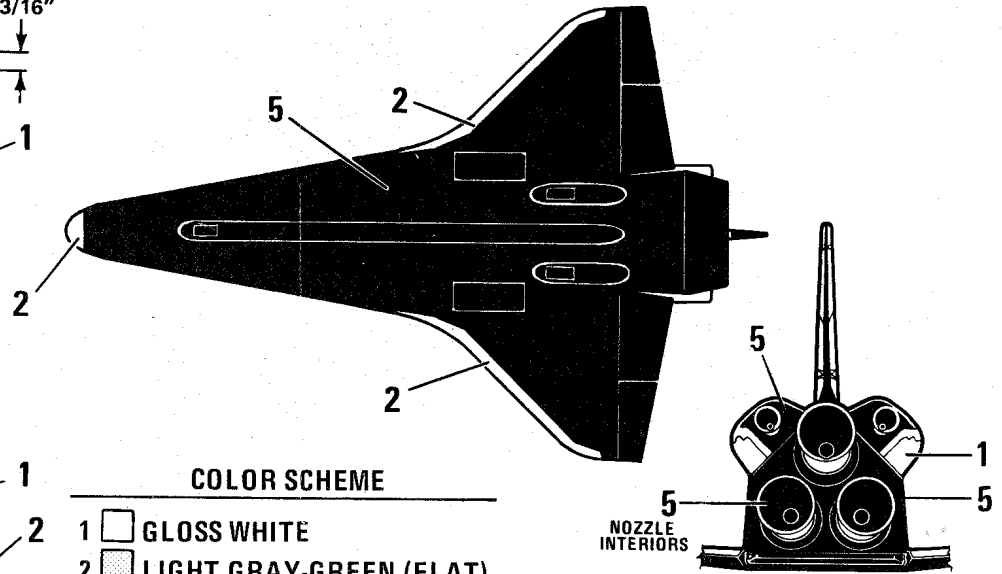

## COLOR SCHEME

- 1 GLOSS WHITE
- 2 LIGHT GRAY-GREEN (FLAT)
- 3 MEDIUM METAL GRAY
- 4 LIGHT TAN (FLAT)
- 5 BLACK (FLAT)
- 6 BROWN (FLAT)

5 Apply the four small panel decals (part Z) to the SRB units. Refer to the illustration for proper location. To apply decals, cut out a decal section and dip it in lukewarm water for 10-20 seconds. Hold decal until it starts to uncurl or slides easily on the backing sheet. Use a brush to "wet" the model surface where decal will be applied. Slide decal off the backing sheet and onto model. Blot excess water away with a damp cloth. Avoid touching decals until they dry completely.

1 Paint Booster and Orbiter separately. Paint the exposed portions of the SRB display nozzles and thermal curtains light tan. Set aside to dry.

2 Apply a thin base coat of gloss white spray enamel to the Booster. Allow paint to dry. Apply a final finish coat of gloss white. Use light, even passes over the model until it is evenly covered. Set aside to dry completely.

3 Apply one thin finish coat of gloss white spray enamel to the Orbiter. Paint only the top half of the model which will be white in color. Avoid heavy buildups of paint because it adds extra weight to the Orbiter. Allow paint to dry completely.

4 Apply two coats of sanding sealer to the wood parts of the fin units. Sand lightly between coats. Paint the fin units flat black. Set aside to dry.

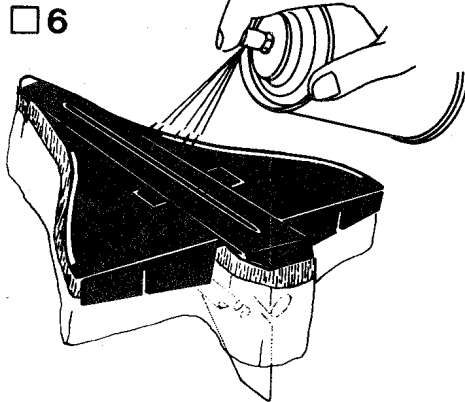

Use masking tape and the plastic kit bag to cover the top portions of the Orbiter which will remain white (color #1 in illustrations). Be sure to smooth the masking tape edges firmly along the required color outlines. Paint the entire underside of the Orbiter flat

black (color #5 in illustrations). Remove tape and plastic bagging immediately after spraying. Carefully pull back the masking tape to avoid pulling away the white paint.

7 Paint the Orbiter nose and wing leading edges light gray-green (flat) as shown. Paint the Orbiter engine nozzles, and vertical stabilizer as illustrated. When paint is dry, apply the remaining decals. Be careful to notice which decals are to be applied to the left and right side of the Orbiter. NOTE: Some small markings may need to have excess clear trimmed from around the decal for proper fit.

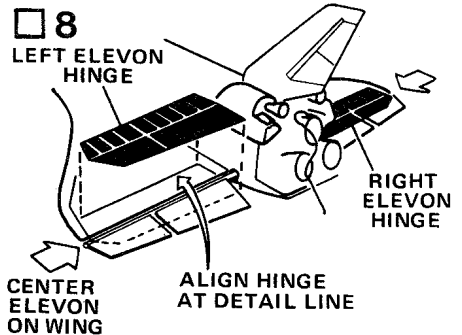

Install the elevon hinges (part Y). Pull the elevon adjustment cord out until the elevons are level with the wing. Crease both hinges on the fold line by folding. Cut out the left hinge on its edge lines. Note that the detail lines at the rear of the wing are a guide for positioning the hinge. Peel away the paper backing and press the front half of the hinge into place on the top of the wing. Hold the elevon so it is centered (left and right), and press the rear half of the hinge onto the elevon. Be sure to hold the elevon level with the wing when applying the hinge. Attach the right hinge to the right wing in the same manner. Apply a final light coat of clear flat spray enamel over decal areas to protect the decals.

# ROCKET PREFLIGHT

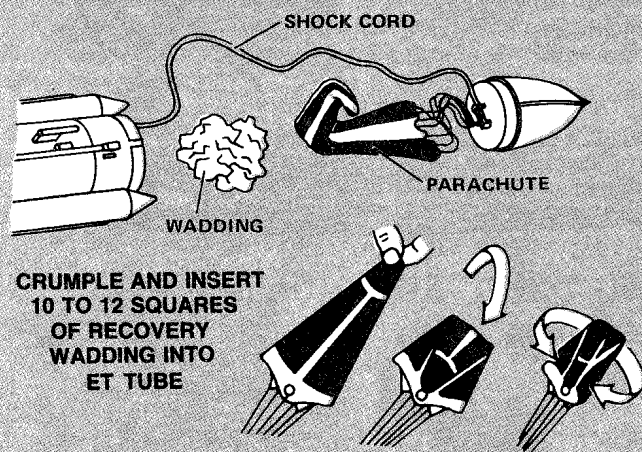

INSTALL FIN UNITS AND ATTACH ORBITER

LEFT FIN UNIT

FOLD PARACHUTE

RIGHT FIN UNIT

REMOVE DISPLAY NOZZLES

ORBITER

LOWER FIN UNIT RING INSIDE AND EVEN WITH SRB TUBE END. TAPE THIS RING AS NEEDED FOR SNUG FIT.

# PREPARE ENGINE

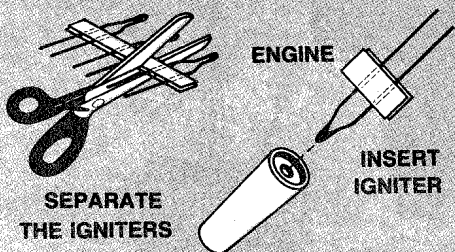

IGNITER TIP MUST TOUCH PROPELLANT DEEP INSIDE NOZZLE OPENING

APPLY AND FIRMLY PRESS TAPE DISC (OR MASKING TAPE) IN PLACE

INSTALL ENGINE IN ROCKET

REAR VIEW WITH FIN UNITS INSTALLED

BEND LEADS

FOLD OVER

HOOK MUST LATCH OVER END OF ENGINE

IGNITER LEADS

# LAUNCH SUPPLIES

To launch your rocket you will need the following items:

- An Estes model rocket launching system
- Estes Parachute Recovery Wadding (No. 2274)
- Recommended Estes Engines: C5-3, C6-3

Use only Estes products to launch this rocket.

Always follow the NAR-HIA\* MODEL ROCKETRY SAFETY CODE while participating in any model rocketry activities.

\*National Association of Rocketry-The Hobby Industry of America

# COUNTDOWN AND LAUNCH

- 10 REMOVE SAFETY KEY to disarm the launch controller.
- 9 Remove safety cap and slide launch lugs over launch rod to place rocket on launch pad. Make sure the rocket slides freely on the launch rod.
- 8 Attach micro-clips to the igniter wires. Arrange the clips so they do not touch each other or the metal blast deflector. Attach clips as close to protective tape on igniter as possible.
- 7 Move back from your rocket as far as launch wire will permit (at least 15 feet).
- 6 INSERT SAFETY KEY to arm the launch controller.

Give audible countdown 5...4...3...2...1

**LAUNCH!!!** PUSH AND HOLD LAUNCH BUTTON UNTIL ENGINE IGNITES

Remove safety key—Replace cap on launch rod.

# MISFIRES

Failure of the model rocket engine to ignite is nearly always caused by incorrect igniter installation. An Estes igniter will function properly even if the coated tip is chipped. However, if the coated tip is not in direct contact with the engine propellant, it will only heat and not ignite the engine.

# FLYING YOUR ROCKET

Choose a large field away from power lines, tall trees, and low flying aircraft. Try to find a field at least 250 feet square. The larger the launch area, the better your chance of recovering your rocket. Football fields and playgrounds are great.

Launch area must be free of dry weeds and brown grass.

Launch only during calm weather with little or no wind and good visibility.

Don't leave parachute packed more than a minute or so before launch during cold weather [colder than 40° Fahrenheit (40° Celsius)]. Parachute may be dusted with talcum powder to avoid sticking.

TAPE ROD JUST BELOW REAR ET LAUNCH LUG

MICRO-CLIPS MUST NOT TOUCH EACH OTHER

BLAST DEFLECTOR

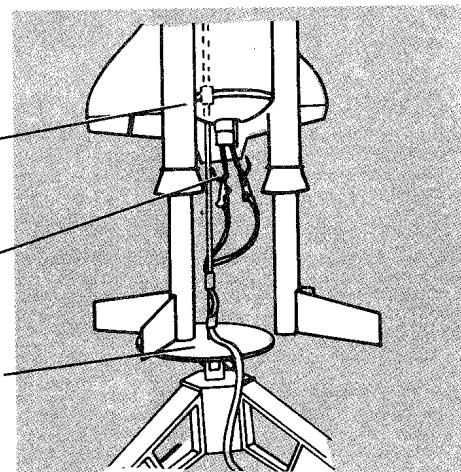

When an ignition failure occurs, remove the safety key from the launch control system and wait one minute before approaching the rocket. Remove the expended igniter from the engine and install a new one. Be certain the coated tip is in direct contact with the engine propellant, then tape the igniter leads firmly to base of engine as illustrated above. Repeat the countdown and launch procedure.

83211B





Atlantis

Discovery

Challenger

Columbia

Enterprise



VSVM

USA



VSVM

ORBITER RIGHT SIDE



United States



United States

ORBITER LEFT SIDE

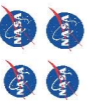

FRONT



Enterprise

Columbia

Challenger

Discovery

Atlantis

Enterprise

Atlantis

PN 37085A  
ESTES INDUSTRIES

SPACE SHUTTLE

KD84B

ESTES

LEFT ELEVON HINGE

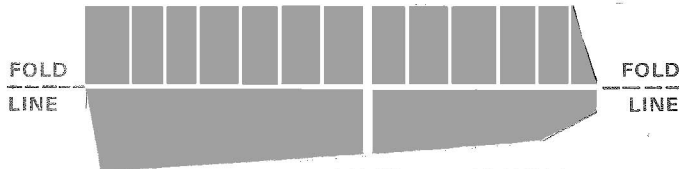
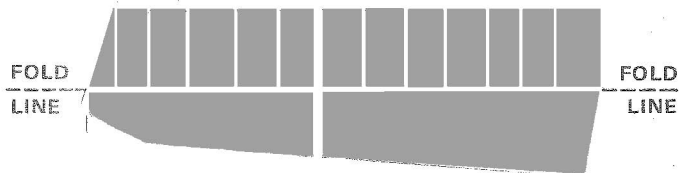

RIGHT ELEVON HINGE

1. PRE-FOLD HINGES ON FOLD LINES.
2. CUT OUT HINGES ALONG EDGES LINES.
3. REMOVE BACKING PAPER AND ATTACH TO ORBITER AS INSTRUCTED.



## Return of the Meatball

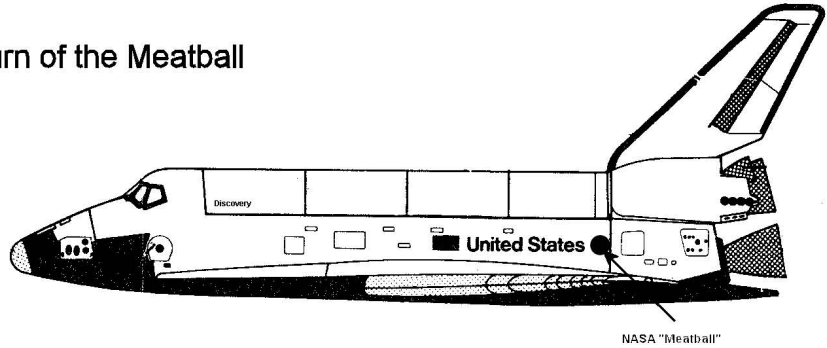
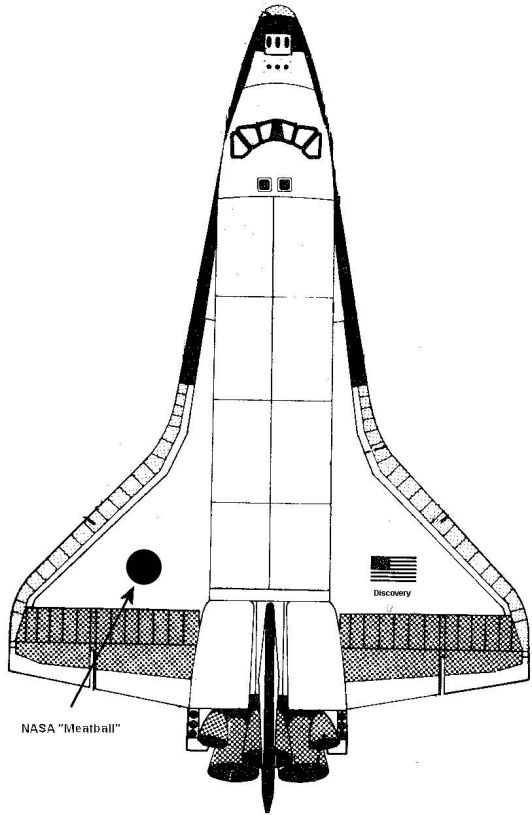

During "Return to Flight" operations in 2005, the Discovery was repainted with the original NASA "meatball" which replaced the stylized NASA logo.

The meatball has been added to the decal sheet.

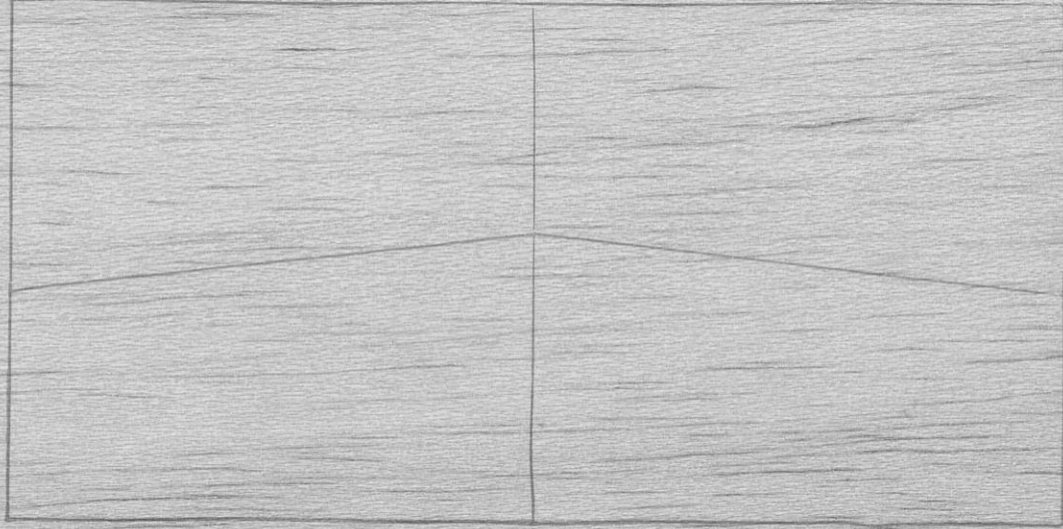

PN32294 ESTES

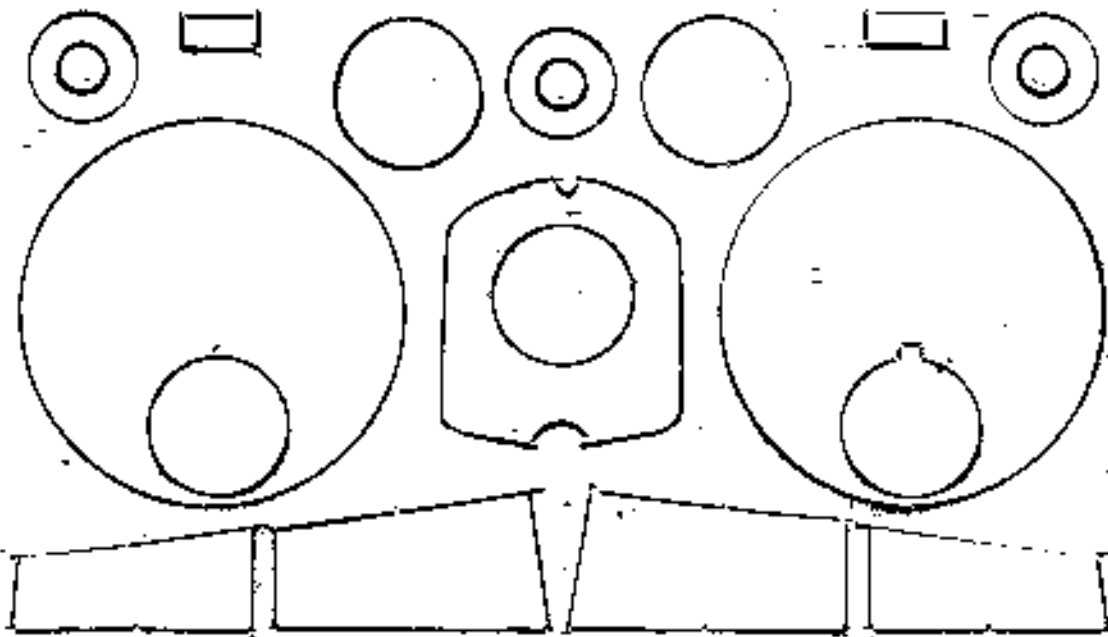
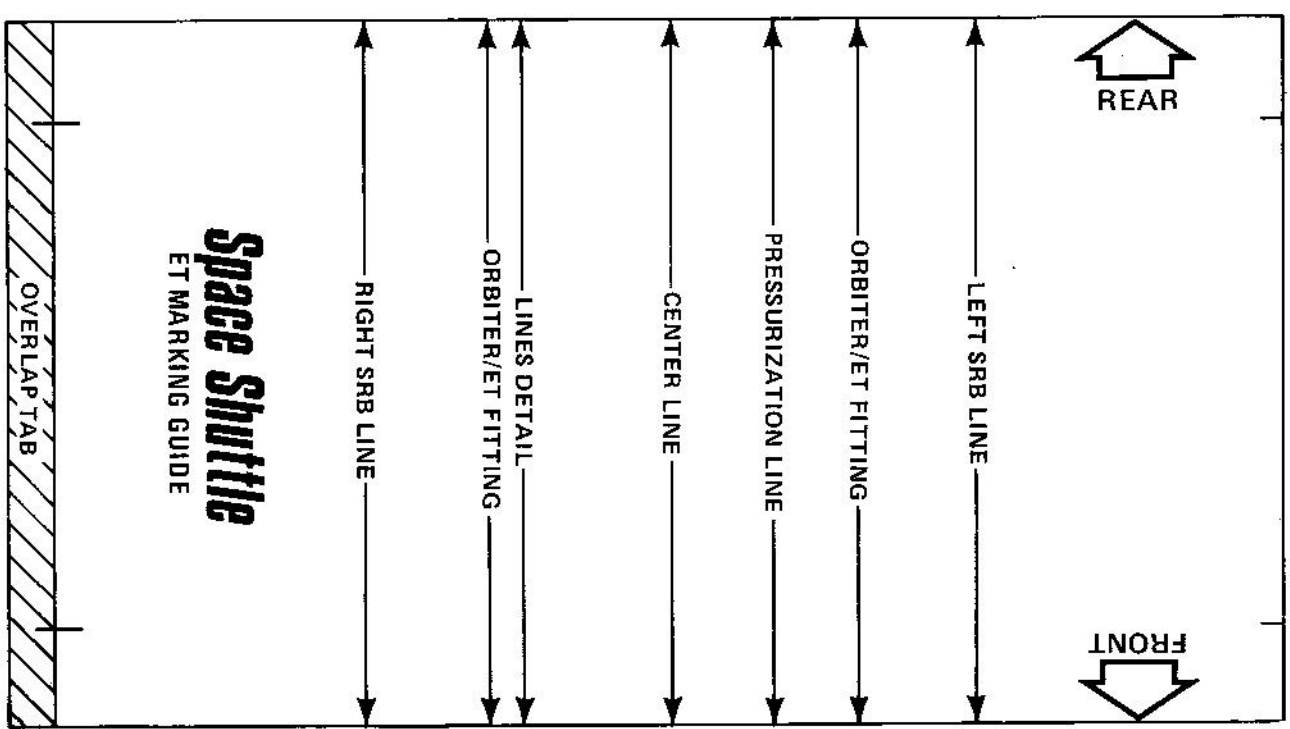
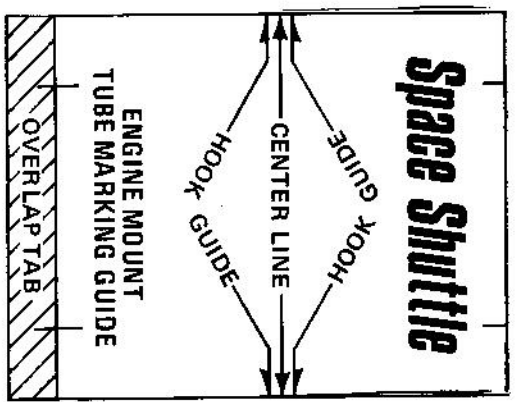
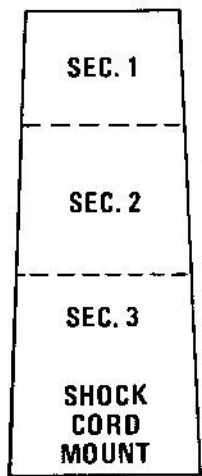
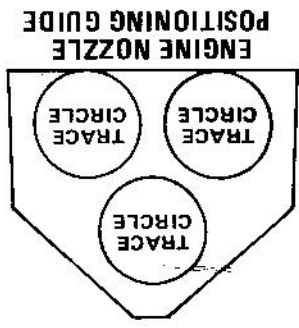
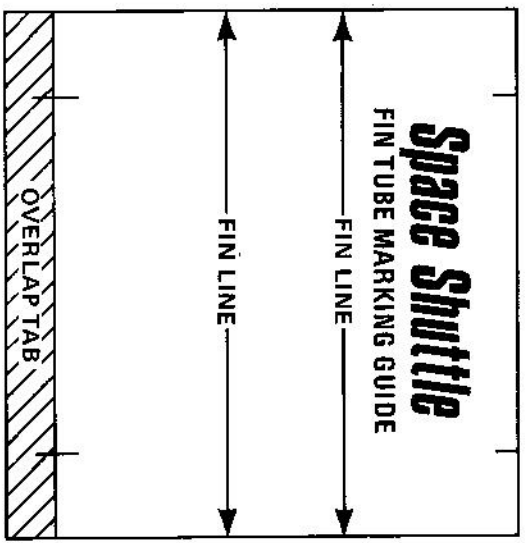
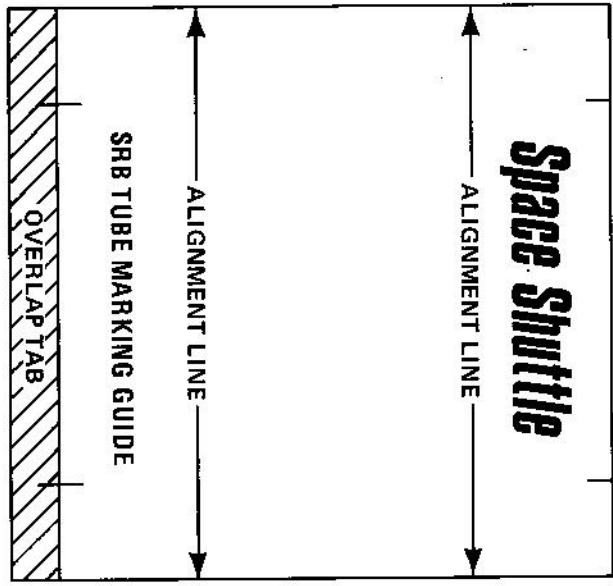
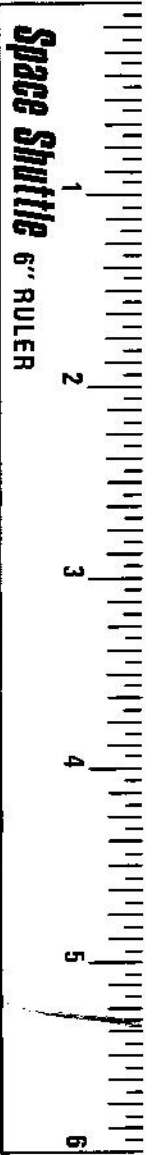

Fig. 1006





SPACE SHUTTLE PATTERN SHEET  
 ESTES INDUSTRIES PN 83215A

90726 No

