

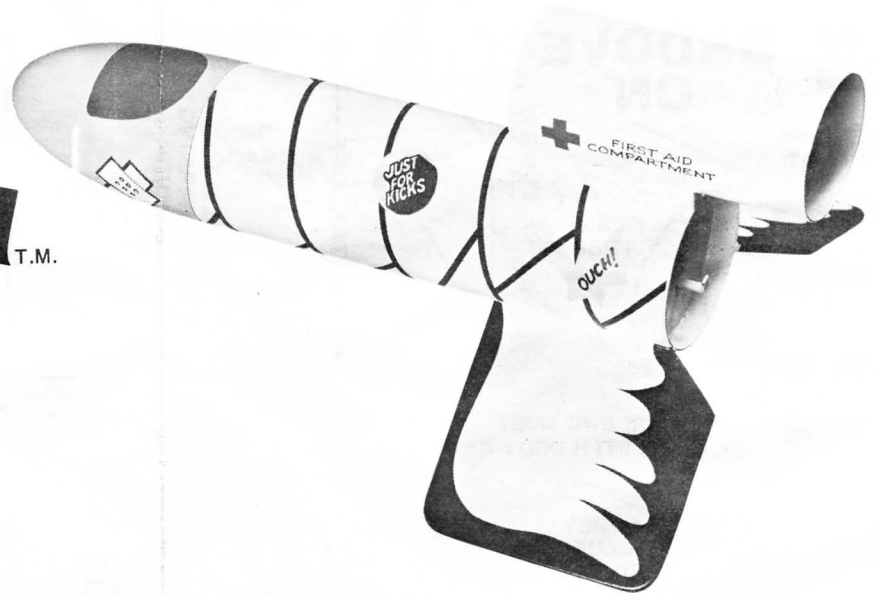

A SUBSIDIARY OF DAMON

Goonybird T.M.



PARTS LIST

KIT NO. 0854

- (A) 1 Body Tube.....BT-5BJ
- (B) 1 Engine Hook.....EH-3
- (C) 1 Centering Rings.....RA-560
- (D) 1 Body Tube.....BT-60R
- (E) 1 Die-Cut Fin Sheet.....BF-00854
- (F) 1 Body Tube.....BT-55J
- (G) 1 Shock Cord Mount.....SCM-50
- (H) 1 Shock Cord.....SC-1B
- (I) 1 Nose Cone.....PNC-60L
- (J) 1 Nose Cone Adapter.....PNCA-60L
- (K) 1 Parachute.....
- (L) 1 Shroud Line.....|...PK-12
- (M) 1 Tape Discs (Strip of 6).....|
- (N) 1 Launch Lug.....LL-2A
- (O) 1 Display Stand.....09014
- (P) 1 Engine Casing.....EC-8
- (Q) 1 Decal Sheet.....37354

WARRANTY: Goonybird model rockets are guaranteed by Estes Industries against manufacturing defects. Any part found defective will be repaired or replaced without charge providing the defective part is returned post-paid to Estes Industries, Customer Service Department, Penrose, Colorado 81240. For fastest service, please send only the defective part.

In addition to the materials included in this kit, you will also need: white glue, plastic cement, modeling knife, scissors, sanding sealer, medium and fine grit sandpaper, paint or dope. **IMPORTANT:** Use white glue for all balsa-body tube construction. Use only plastic cement for nose cone assembly.

1 THE ENGINE THING

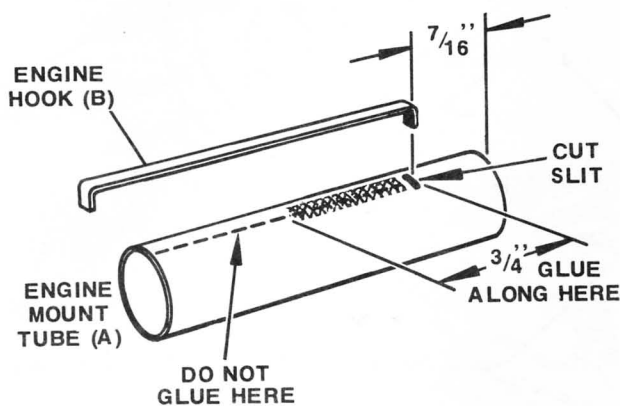

Cut a 1/8" slit in the engine mount tube, 7/16" from one end. Apply a drop of white glue to the slit and also straight along the tube for approximately 3/4". Push one end of the metal engine hook into the slit. Press the hook into the glue and align straight along the tube. Wipe away any excess glue.

MISSILE TOE Flying Model Rocket

CONSTRUCTION TIP: Why not have one of your parents or big brother or sister join in the fun of constructing your Goonybird? They are sure to have a great time, and their assistance will be helpful. Remember good construction is essential if you want your Goonybird to fly correctly. When launch day arrives have the whole family take part in the excitement and fun of launch preparation, countdown, tracking, and recovery. It's a real thrill for everyone to watch your Goonybird lift off and return gently to earth ready for another freaky flight. A "well-constructed" Goonybird will bring you many hours of family fun and enjoyment.

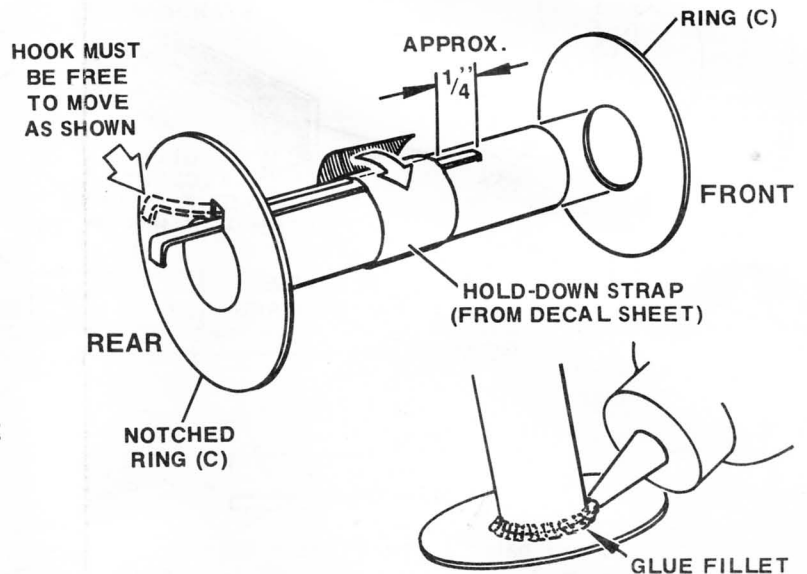

Tightly wrap the hold-down strap (from decal sheet) around the hook and tube as shown. Center the notched paper ring over the hook and glue to the tube REAR. Hook must be free to move as shown. Glue the other ring to the front of the tube. Run lines of glue (known as "glue fillets") around the front and rear ring/tube joints. Allow mount assembly to dry completely.

2 GROOVE ON

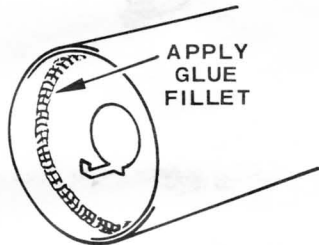
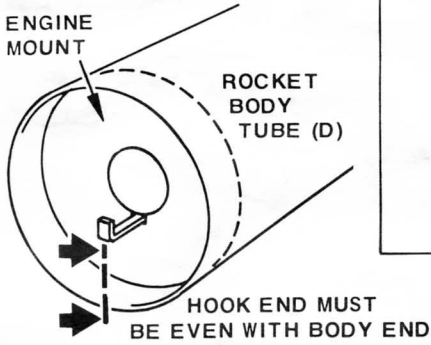

REAR

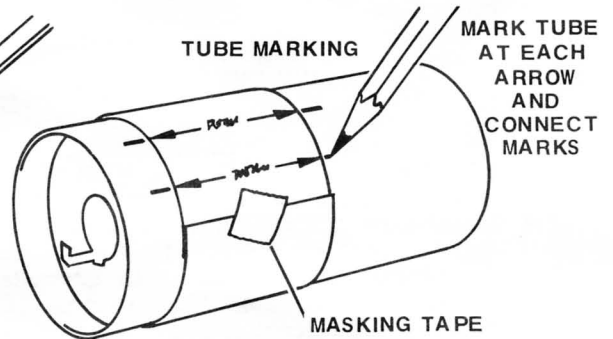
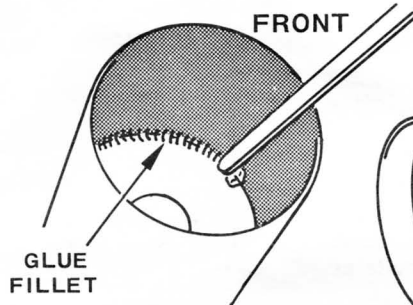
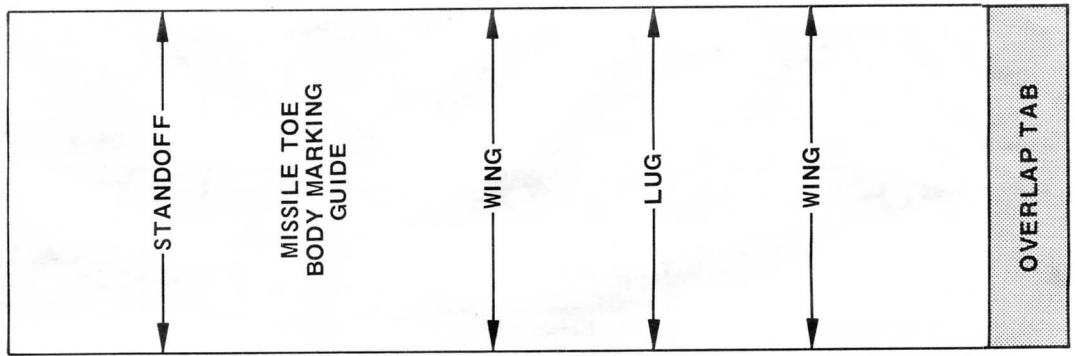

Insert engine mount into the rocket body tube. End of metal engine hook **MUST** be even with body tube end. (For quickest alignment, simply press body tube end against table top and engine mount will automatically move forward to align with tube end.)

Apply a line of glue, or "fillet", around the REAR ring/tube joint. Apply a glue fillet also to the FRONT ring/tube joint. A stir stick, soda straw, or paint brush

will be helpful to apply glue inside body tube.

Cut out the body tube marking guide from the instruction sheet. Wrap it around the rear of the tube so its ends match. Temporarily tape the guide in place. Mark the tube at each arrow point. Remove the guide and draw straight lines connecting matching front and rear marks. Draw the launch lug line forward the length of the tube.

3 WINGS AND THINGS

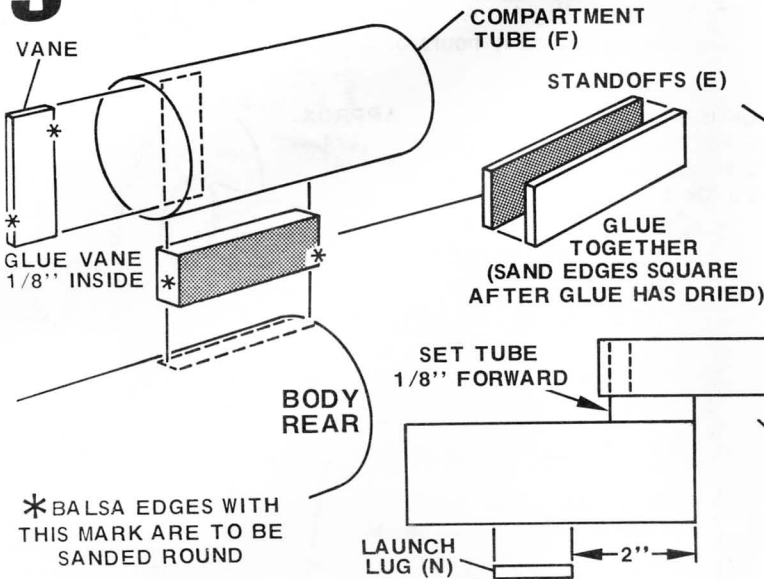

Glue the two balsa standoff pieces together as shown. Hold pieces together until the glue sets. Sand round all balsa part edges as noted by this mark (*) in drawing. (You may wish to sand part sides smooth before removing them from the balsa sheet.)

Glue the standoff to the body tube rear on its alignment line. Rear of standoff must be even with the tube rear.

Glue the balsa vane into the compartment tube, 1/8" inside from the end as illustrated.

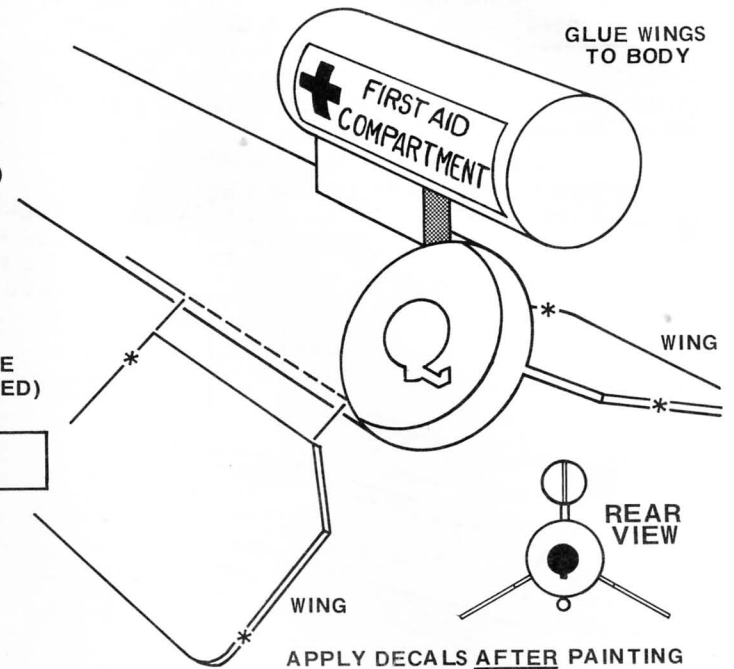

Now glue the compartment tube to the standoff. Position the tube end 1/8" forward from the standoff front as shown. Be sure that the tube is not crooked, but parallel, or in line with the larger rocket body tube.

Glue the launch lug to the body on its line, 2" from the tube rear.

Next, apply glue to the "body tube edge" of one wing and glue it to the body on its line. The end of the "body tube edge" must be even with the tube rear as shown. Glue the other wing to the opposite side of the body.

4 RECOVERY STUFF

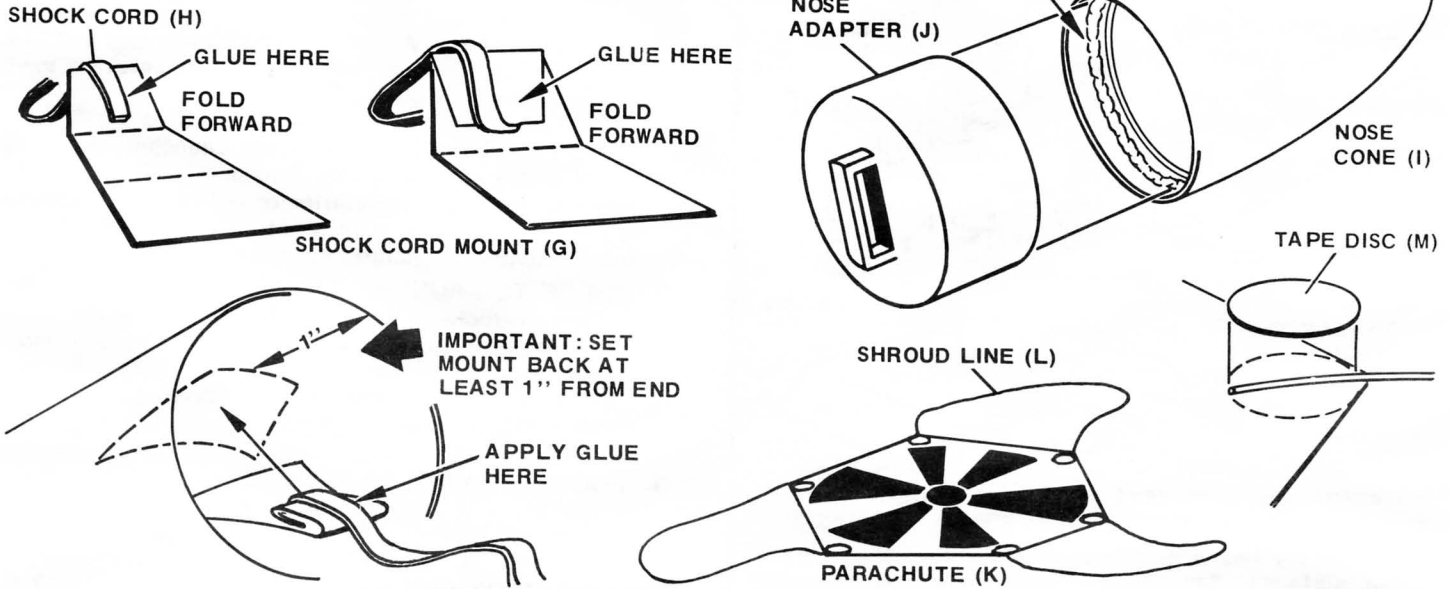

Cut out the shock cord mount and prefold along dotted lines. Apply glue to section 1 and lay shock cord end into glue. Fold this first section over. Spread glue over back of first section and exposed part of section 2. Lay shock cord as shown and fold over again. Clamp the unit together with your fingers until the glue sets. Apply glue to the mount as illustrated. Press the mount into position against the tube wall and hold it until the glue sets.

Trim away any excess plastic from the two nose cone pieces. Run a line of PLASTIC CEMENT around the nose cone just inside from the end. Push the adapter piece firmly into the nose cone until it stops.

Cut out the parachute on the edge lines marked on the plastic. Cut the shroud line into three equal lengths. Attach the line ends to the 'chute corners with tape discs as shown.

5 GETTING IT ALL TOGETHER

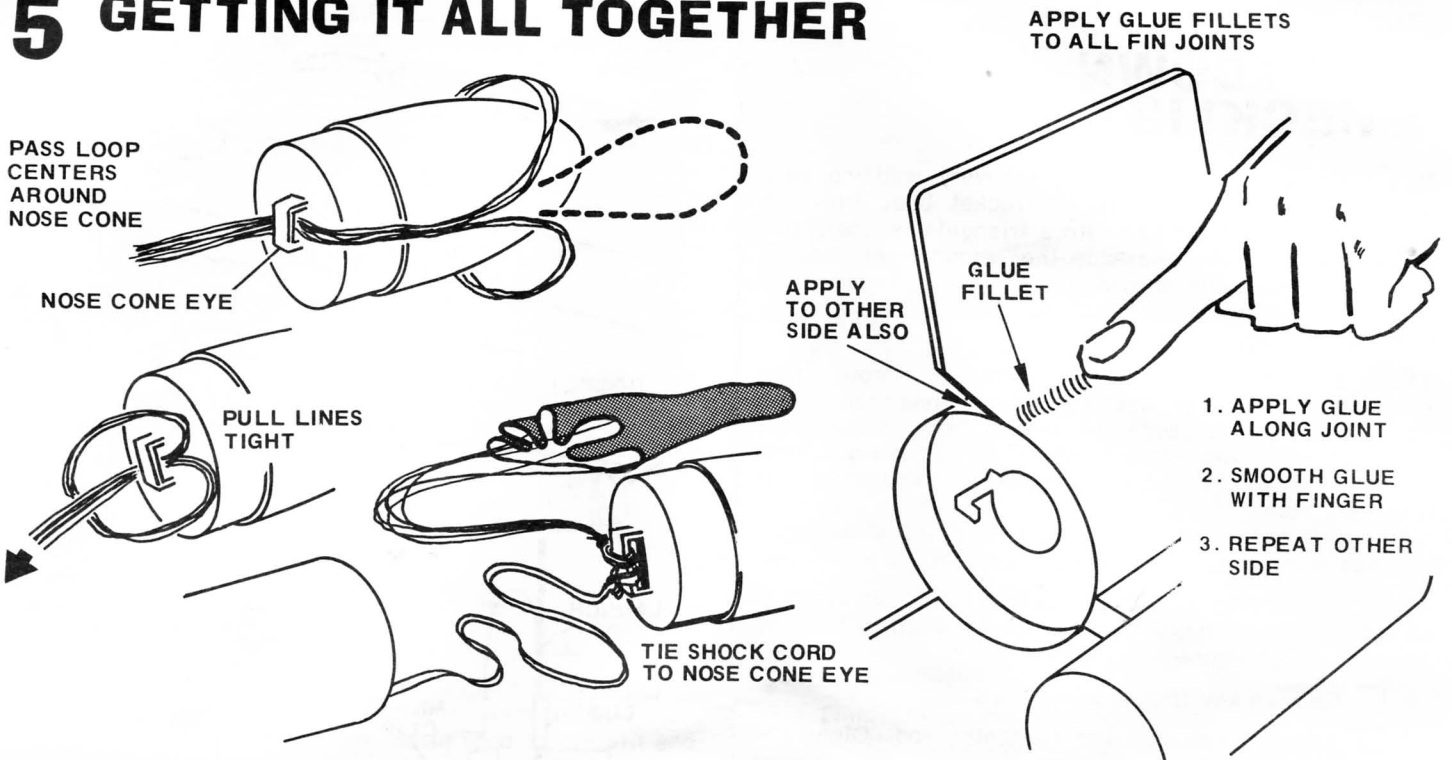

Pass the shroud line loop "centers" through the nose cone "eye". Now pass the loop centers around the nose cone as shown and pull lines tight to secure parachute. Tie the shock cord to the nose cone "eye".

Apply a "glue fillet" to both sides of each fin/body joint. After applying glue, smooth fillet with finger. Fillet should then be smooth and bubble-free. Allow glue fillets to dry several minutes before proceeding to next fin joint. Support model horizontally while the glue dries.

6 FINISHING TOUCHES

DECOR SCHEME

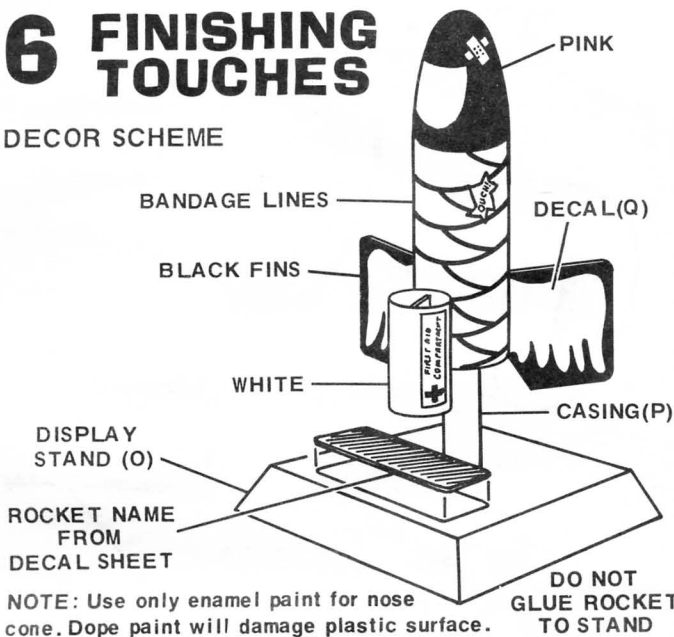

Apply two or more coats of sanding sealer to all balsa surfaces. Sand lightly with extra-fine sandpaper between coats. Repeat until all wood pores are filled and the surfaces are smooth.

Spray the rocket body with a light base coat of white enamel paint. Allow to dry. Follow with a light finish coat of white. Paint the nose cone pink or flesh color.

After all paint has dried overnight, apply the stick-on decals as shown in the instructions and decor scheme illustration.

If desired, you may use paint, marking pen or thin model striping tape to stimulate the bandage wrapping lines.

Assemble the model display stand as directed in the instructions on the back of the stand.

EASY STEPS TO LAUNCH YOUR ROCKET

1. WHAT YOU WILL NEED:

- To fly your Goonybird you will need the following items not included in this kit:
- Estes model rocket engines and igniters 1/2A3-2T, A3-4T, A10-3T engines or Estes Firing Line Relaunching Components No. 0709.
 - Recovery wadding. RP-1A
 - Launching system Estes Firing Line Launcher #0702; or Solar Launcher, Solar Igniters and Porta-Pad Tripod.

See your local Estes retailer or fill out the enclosed request card for more information on model rocketry and Goonybird launching supplies.

2. WHERE TO LAUNCH:

Goonybird rockets are ideal for small cleared areas away from buildings, power lines or tall trees. Choose a field at least 100 feet in diameter. A neighborhood park or baseball diamond will serve quite nicely. Other suitable sites are school yards, football fields or large parking lots.

3. ROCKET FLIGHT PROFILE:

A typical model rocket flight is shown at right:

- Ignition and lift-off.
- Acceleration and coasting.
- Parachute deployment.
- Recovery and touchdown.

Your rocket may be flown many times. Simply discard used engine and replace with new engine, igniter and recovery wadding as instructed.

4. Follow the COUNTDOWN CHECKLIST below for each flight.

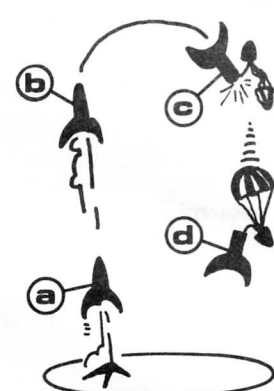

COUNTDOWN CHECKLIST

12. Crumple four squares of recovery wadding very loosely and pack them into the rocket body from the front. Gather the parachute into a triangular shape. Fold the 'chute as shown and wrap the shroud lines loosely around it. (For maximum opening reliability, lightly dust the 'chute with ordinary talcum powder before each flight, especially in colder weather.)

11. Pack parachute, shock cord and shroud lines neatly into the rocket and slide nose cone into place. Nose cone should separate easily from rocket body tube, but not be extremely loose. If fit is too tight, sand inside of body tube end and shoulder of nose cone with fine sandpaper.

If nose cone is too loose, add a wrapping of transparent tape or masking tape to the shoulder of the nose cone.

10. Select an engine and install an igniter as directed in the engine instructions. (Use A3-4T engines for first flights.) Insert engine into rocket.

- Remove key from launch panel.
- Slide rocket onto the launching rod. Clean the micro-clips and attach them to the igniter.
- Alert all personnel that rocket is ready for launch.
- Arm the launch panel.

Begin Final Countdown: 5-4-3-2-1 **BLAST-OFF!**

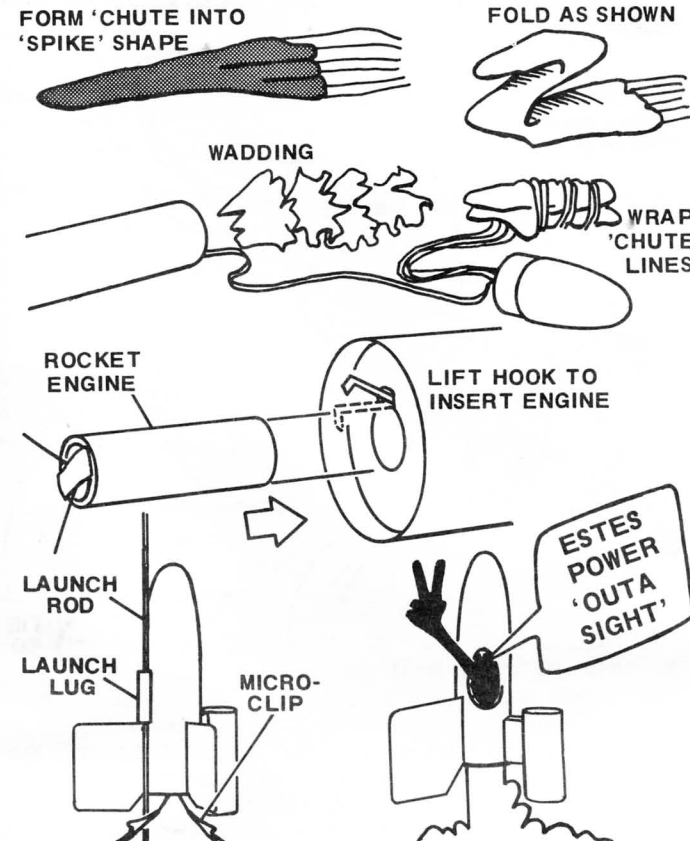

ESTES INDUSTRIES, PENROSE, COLORADO 81240

FRONT

WING

VANE

BODY TUBE EDGE

FRONT

STANDOFF

BF-00854



BODY TUBE EDGE

FRONT

WING

STANDOFF

FRONT

FIRST AID
COMPARTMENT



FIRST AID
COMPARTMENT

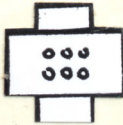

Missile Toe

37354

HOLD-DOWN STRAP

