

INTRODUCTION & BACKGROUND

SCALE

Honest

U.S. ARMY Surface

PARTS LIST

PART NO.	PART NAME
1	Body Tube
2	Nose Cone
3	Stabilizer Fins
4	Strengthening Bands
5	Spin Rockets
6	Launch Lug
7	Lug Stand-Off
8	Engine Mounting Tube
9	Centering Rings (2)
10	Thrust Ring
11	Chute Canopy
12	Shroud Line
13	Tape Discs
14	Engine Spacing Tube
15	Decal

In actuality, the full-size HONEST JOHN is a standard, operational, surface-to-surface, short range artillery weapon of the U.S. Army. It employs a solid propellant rocket motor, is 27 feet in length, and weighs 12 tons. It will carry a 1500 lb nuclear warhead 12 miles to a target on the ground.

It is fired from a mobile launcher and uses a pre-set guidance computation, without any in-flight guidance system. Upon leaving the launcher, peripheral rockets around the base of the enlarged nose cone fire causing the rocket to roll in flight, and thereby "spin stabilize" the missile.

Centuri's HONEST JOHN kit is a 1/25th true scale of the HONEST JOHN model no. 1236F-M521. It is one of the most popular of all the Centuri models. With care in construction and launching, it will last for many, many flights.

In addition to the parts supplied, you will need the following items to assemble this kit:

- Modeling knife or single edge razor blade
- White glue or modeling cement
- Paint for finishing - preferably spray type
- Fine sandpaper - Scissors - Pen or pencil

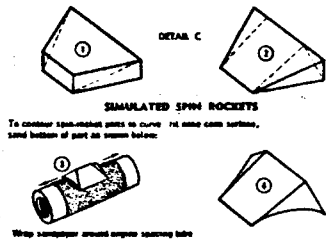

ASSEMBLE & INSTALL ENGINE MOUNT

The engine mount consists of one mounting tube (.715" ID x 3" long), two #8 Centering Rings, and one #7 Thrust Ring. These parts should be assembled with white glue or model cement as shown in the Engine Mount detail illustration.

First, glue the centering rings securely to the mounting tube. The forward ring should be positioned even with the end of the mounting tube and the rear ring about 1" from the aft end of the mounting tube. Next, glue the thrust ring inside the forward end of the mounting tube, with the end of the ring even with the end of the tube. Set the mount aside and allow to dry.

After the mount has completely dried, apply a heavy bead of white glue around the top outer rim of both centering rings. Insert the spacing tube into the mount and push the mount into the body tube until the end of the spacing tube is even with the end of the body tube. See Detail A.

To force the glue into the tube/ring joints, roll the tube around slowly and hammer it against your hand. Set the tube-mount assembly on the mount end and allow to dry.

ATTACH MOTOR STRENGTHENING BANDS

From the printed paper stock, cut out all four strengthening bands. One at a time, apply white glue to one side of each band and carefully wrap band around body tube in the position as shown above.

ASSEMBLY IN

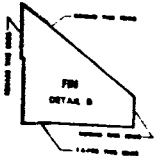

Honest John

Face-to-Surface Rocket

RIG PARACHUTE & SHOCK CORD

Assemble the parachute as shown in the enclosed Chute Assembly Directions. Attach one end of the rubber shock cord to the body tube as shown below. Cut two slits, about 3/8" long and 1/4" apart, in the body tube one inch down from the top end. Insert one end of the rubber cord into the tube from the top end, and depress the tube paper between the slits. Bring the cord out through the first slit, and back into the body tube through the second slit. Apply glue to the body tube to form a good bond.

Thread the screw eye into the nose cone base, and unscrew the eye from the cone. Squirt glue into the resulting hole, slip the nose weights over the screw eye, and re-thread the eye into the cone. Now tie the shroud ends to the screw eye together with the rubber shock cord as shown in the assembly drawing. Fold the chute temporarily, insert into the top of the body tube, and place nose cone in place.

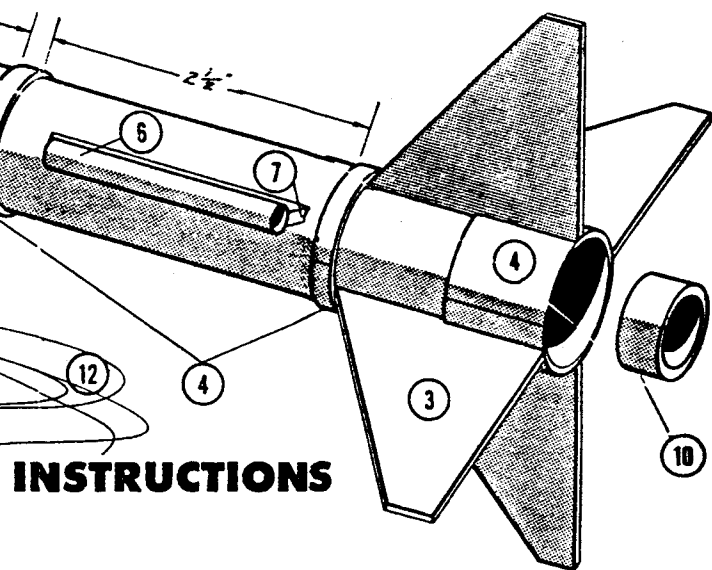

INSTRUCTIONS

ATTACH STABILIZER FINS

From the printed balsa sheet, carefully cut out the four fins. With fine sandpaper, round the leading and tip edges, and taper the trailing edges of all fins. Square the root chord edge. See Detail B.

Cut out the enclosed Fin Positioning Guide, wrap it around the body tube base, mark the fin locations with a pen or pencil.

Apply white glue or modeling cement to each fin root chord edge, one at a time, and also along the body tube where fins are to be attached. When glue has just begun to set, place fins in position along the body tube. Stand tube on top end and allow to dry. With the Fin Allignment Guide, check the angle between fins before glue has completely set. Opposite fins should be in line with each other, and adjacent fins should be exactly 90 degrees apart.

For increased fin strength, run a narrow fillet of glue along each fin-tube joint after the initial glueing has thoroughly dried.

ATTACH LAUNCH LUG & STAND-OFF

In order for the launching rod to clear the bulbous nose cone, it is necessary to extend the launching lug away from the body tube. This is done, first by glueing the lug to the short edge of the balsa stand-off, then glueing the stand-off to the body tube as shown in the Assembly Drawing. Make sure that the lug lines up with long axis of the body tube.

FORM & ATTACH SIMULATED SPIN ROCKETS

After the actual military version of HONEST JOHN leaves its launcher, peripheral spin rockets around the nose cone base fire, thereby "spin stabilizing" the HONEST JOHN.

On a model however, we can only simulate these spin rockets. Cut out the four trapezoid-shaped pieces and carefully trim and sand to the shape shown in Detail C.

FINISHING THE HONEST JOHN

To obtain maximum altitude flights, all model rockets should be painted to a gloss finish. First, the grain texture of the nose cone and fins should be filled in with several coats of balsa filler. Sand smooth between applications. The body tube does not require this treatment. Finish entire model with lightweight paint such as spray dope or laquerized enamel. To aid in tracking, use bright colors such as white, yellow, orange, or red. Flourescent colors are quite easy to spot at high altitudes.

LAUNCHING THE HONEST JOHN

The HONEST JOHN single stage model can be powered by any of the following engines: 1/2A6-2 A5-4 B6-4 C6-5

The engine must remain in place during the entire flight. Friction fit the engine into the mount until snug. It may be necessary to wrap a layer or two of tape around the engine to obtain this snug fit. If the engine is too tight to begin with, sand down the paper casing just enough to permit a snug friction fit.

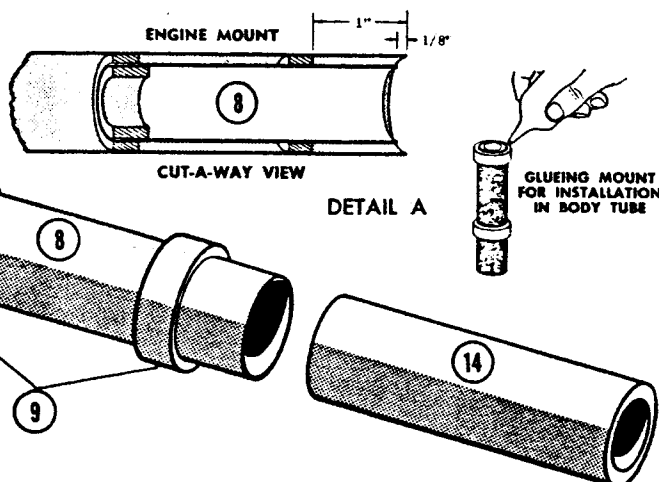

Complete ignition and launching instructions are included with all Centuri rocket engines. Launch the HONEST JOHN from a 1/8" diameter x 36" long launching rod. Use electrical ignition only, as outlined in the Engine Operating Instructions.

The HONEST JOHN should be launched from the center of an open field measuring at least 500 feet on a side or having the equivalent area. Choose a clear unobstructed launch site away from houses, highways, and trees. Do not launch model rockets in backyards or in city streets. Always give a short countdown to alert spectators before launching.

For further information concerning rocket engines, kit, ignition devices, launching apparatus, or accessories, write to:

CENTURI ENGINEERING COMPANY
P.O. Box 1988
Phoenix, Arizona 85001

IPB-12



ROOT CREDIT
GAIN THIS CREDIT TO YOUR FAVOR

ROOT CREDIT
GAIN THIS CREDIT TO YOUR FAVOR

#KXC25

HONEST



HONEST

1

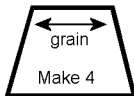
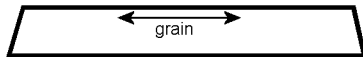
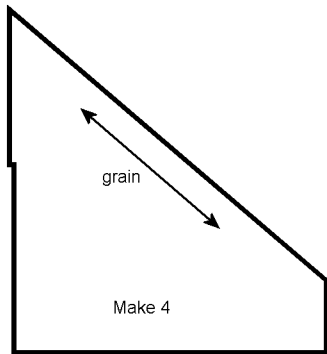
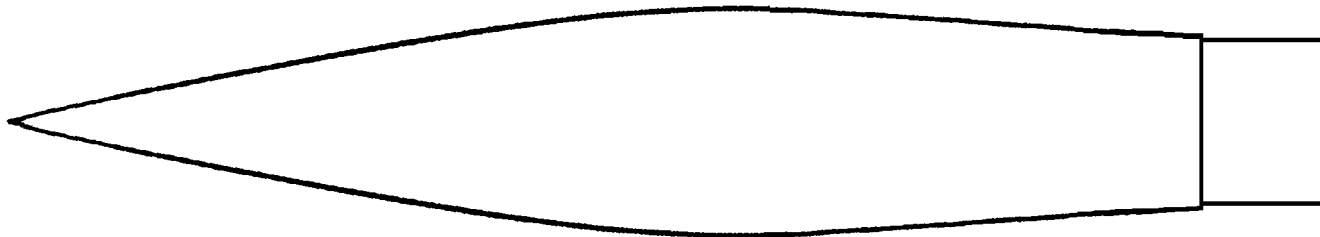

Centuri Honest John

1"



3/32" balsa

Support bands (card stock):

1/8" X 4-7/8" (make 3)

1" X 4-7/8"

#8 body tube, 7-1/4" long

The Centuri Honest John (KC-25) was available from 1967 thru 1974.
(Fin pattern supplied by Mack Yocum.)

Main Body tube: ST-88 8 inches long

Nose Cone: BC-86 5.5 inches

Chutes: Twelve inch

Fins: Pre-printed 3/32" balsa

Detailing:

I don't have patterns for the motor strengthening bands, but these can be easily replicated by cutting the strips from a manila folder or index card.

Also included on the printed balsa sheet, but not available here, were patterns for the spin rockets. One fix would be to take the patterns from the Estes HJ plans and reduce them by 7%.

If anyone has these two patterns (along with the decal), please forward scans on to Scott.

SEL 01.20.03
selannan@yahoo.com