

TOOLS YOU WILL NEED:
 REQUIRED
 White Glue
 Plastic Glue
 OPTIONAL
 Spray Paint

EXCALIBUR

Centuri

SKILL LEVEL

1	2	3	4	5
Engine A	Engine B	Engine C		
380	720	1350		
Feet	Feet	Feet		

Altitudes depend greatly on the quality of assembly and finishing.



EXCALIBUR

FLYING MODEL ROCKET

- Big - - Over 2 Feet Tall
- Die-Cut Fibre Fins
- Chrome Trim & Decals
- Quick-Change Engine Lock



RECOMMENDED ENGINES

Not included
 A8-3 B4-4
 C6-5

SPECIFICATIONS

Length 26.5"
 Body Dia. 0.91"
 Net Wt. 1.60 oz.

Centuri

#5008
 (KA-8)

- 13** Insert the fastener 1" past the top of the body tube. Press firmly against the inside wall of the tube with a finger or eraser end of a pencil. NOTE: All edges of the fastener must be firmly contacted to the tube to insure a permanent bond.

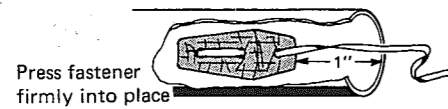

- 14** NOTE: Engine tube assembly will be glued into place in next step. The exposed end of engine tube may be painted a contrasting color before gluing it in, if desired. Don't get paint on the centering ring.

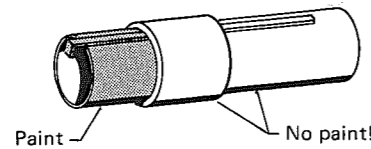

- 15** Test-fit the engine tube assembly into the body tube. (Smooth inside edge of body tube, if necessary.)

- 16** Remove the engine tube assembly, and run a generous bead of glue around the inside of the body tube. Push assembly back in place with a firm, even motion, until 3/8" of the engine tube protrudes.

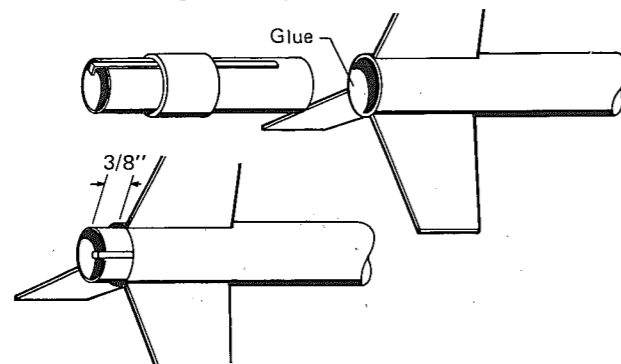

- 17** IMPORTANT: Run a bead of glue along both sides of all fin-body tube joints. Using your finger, smooth the glue into even fillets. Allow to dry, checking alignment again.

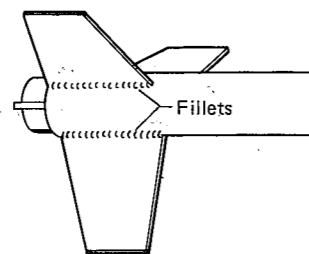

- 18** Apply a bead of glue to one side of the launch lug. Place the lug against one of the main fins along the body tube. Reinforce lug with glue fillets on each side.

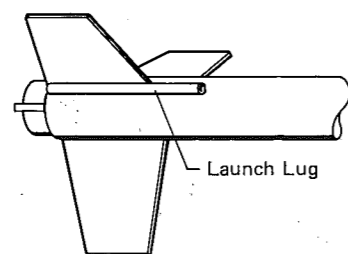

- 19** The paper-surfaced fins will take paint nicely, but the edges need to be sealed for best appearance. Apply one or two thin coats of glue, using a small dab on your finger. Wipe excess glue away.

- 20** When painting plastic parts, never use dope or lacquer! First, spray with an enamel primer. The plastic cone may then be spray painted in place on the model, or it may be removed for painting a separate color.

SUGGESTED COLOR SCHEME:

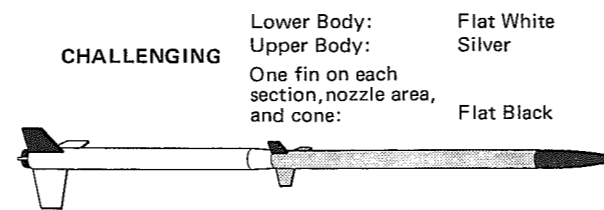
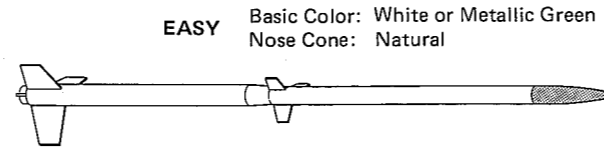

- 21** Spray painting your finished model with a fast-drying enamel will produce the best results . . . IF IT IS DONE PROPERLY!!! Most important is the number of coats of paint. DO NOT try to paint your model with one heavy coat! Instead, give it a couple of quick, light coats first and THEN a finish coat. Let each coat dry before applying the next.

SPRAYING A TYPICAL MODEL ROCKET

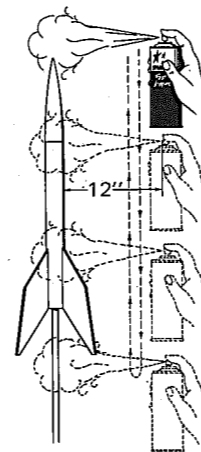

- 22** Apply the decals, one at a time, according to the instructions printed on the decal backing paper. The pressure-sensitive chrome trim may be simply wrapped around the upper body tube. If preferred, cut neatly into narrow strips for "customizing" as shown.

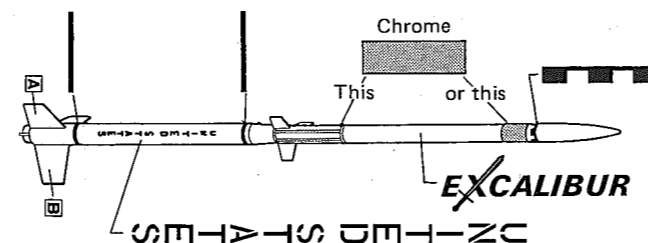

ENGINES

Igniters and complete engine installation instructions are included in "Engine Operating Instructions" which accompany all Centuri engines.

The EXCALIBUR can be launched with the following engines:

- A8-3 LOW ALTITUDE — for first test flights and small launch areas.
B4-4 MEDIUM ALTITUDE — for general flying and medium size launch areas.
C6-5 HIGH ALTITUDE — for extremely high flights and large launch areas.

FLIGHT PREPPING

1. Inspect shock cord fastener for firm bond.
2. Insert Flameproof Parachute Wadding according to its directions.
3. Tuck in shock cord.
4. Roll chute tightly as shown, and insert.
5. Socket nose cone in place.

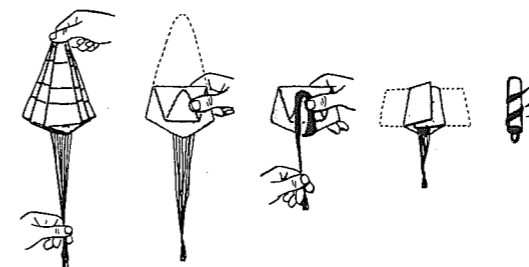

Cone fit: Snug, but not too tight.

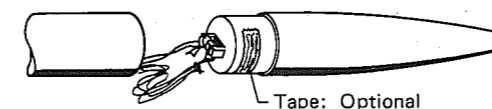

Carefully prepare and check all parts of your rocket before each flight.

Launch the EXCALIBUR from any standard model rocket launcher having a 1/8" diameter x 36" long steel launch rod.

Do not leave the rocket sitting in the sun for long periods as this may soften the adhesives.

Referring to the specific instructions which accompany Centuri launchers and firing panels, mount the rocket on the launcher and prepare for ignition. Avoid eye injury by capping the exposed tip of the launch rod when not actually launching! Follow the instructions and the Safety Code, and have many happy hours with Model Rocketry.



EXCALIBUR

Catalog No. KA-8

The EXCALIBUR is sleek, high-flying rocket, long on looks and performance! This easy-to-build kit features die-cut fibre-fins. These time-savers require no sanding or sealing, as opposed to traditional balsa fins!

The chrome stick-on trim, custom decal sheet, and simulated two-stage appearance add to the value of this budget-priced bird! Use A8-3 engines for first test flights.

This rocket is designed to be launched only from standard remote-controlled electrical launch systems. Always use the recommended engines and recovery wadding. Comply with all Federal, State and local laws.



MODEL ROCKETEER'S SAFETY CODE

CONSTRUCTION

My model rockets will be made of only lightweight materials such as paper, wood, plastic, and thin metallic foils, with the exception of payloads and engine holders made of wirelike material.

ENGINES

I will use only pre-loaded factory made model rocket engines in the manner recommended by the manufacturer. I will not change in any way nor attempt to reload these engines.

RECOVERY

I will always use a recovery system in my model rocket that will return them safely to the ground so that they may be flown again.

WEIGHT LIMITS

My model rocket will weigh no more than 453 grams (16 oz.) at liftoff, and the engines will contain no more than 113 (4 oz.) of propellant, as prescribed by Federal Regulations.

STABILITY

I will check the stability of my model rockets before their first flight except when launching models of already proven stability.

LAUNCHING SYSTEM

The system I use to launch my rockets will be remotely controlled and electrically operated, and will contain a switch that will return to "off" when released. I will remain at least 10 feet away from any rocket that is being launched.

LAUNCH SAFETY

I will not let anyone approach a model rocket on a launcher until I have made sure that either the safety interlock key has been removed or the battery has been disconnected from my launcher.

LAUNCH AREA

My model rockets will always be launched from a cleared area, free of any easy-to-burn materials, and I will only use non-flammable recovery wadding in my rockets.

BLAST DEFLECTOR

My launcher will have a blast deflector device to prevent the engine exhaust from hitting the ground directly.

LAUNCH ROD

To prevent accidental eye injury I will always place the launcher so the end of the rod is above eye level or cap the end of the rod with my hand when approaching it. I will never place my head or body over the launching rod. When my launcher is not in use I will always store it so that the launch rod is not in an upright position.

POWER LINES

I will never attempt to recover my rocket from a power line or other dangerous places.

LAUNCH TARGETS AND ANGLE

I will not launch rockets so their flight path will carry them against targets on the ground, and will never use an explosive warhead nor a payload that is intended to be flammable. My launching device will always be pointed within 30 degrees of vertical.

PRE-LAUNCH TEST

When conducting research activities with unproven designs or methods, I will, when possible, determine their reliability through pre-launch tests. I will conduct launchings of unproven designs in complete isolation from persons not participating in the actual launching.

FLYING CONDITIONS

I will not launch my model rocket in high winds, near buildings, power lines, tall trees, low flying aircraft or under any conditions which might be dangerous to people or property.



CENTURI ENGINEERING CO., INC.
P.O. Box 1988, Phoenix, Arizona 85001

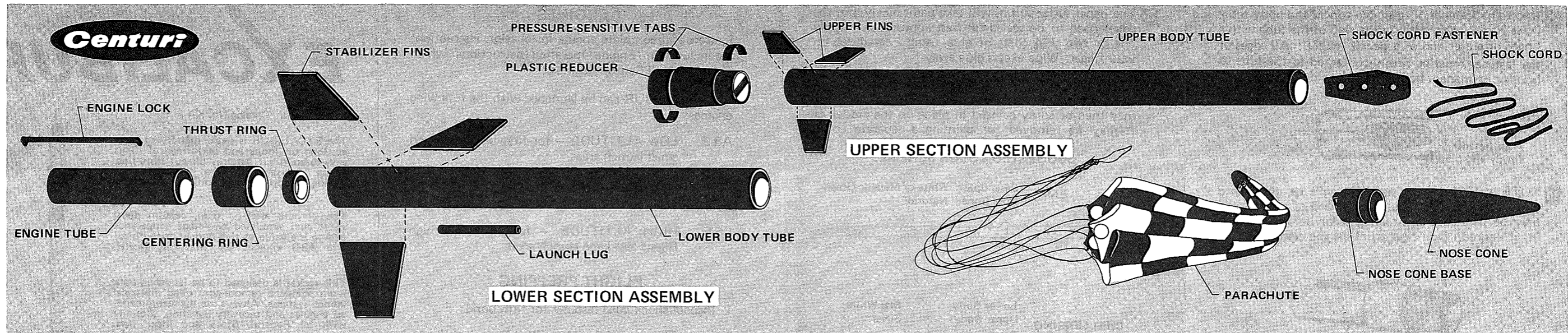

ASSEMBLY INSTRUCTIONS

READ BEFORE STARTING ASSEMBLY

TOOLS: In addition to the parts supplied, you will need the following tools to assemble and finish this kit. DO NOT use model airplane glue for building flying model rockets.

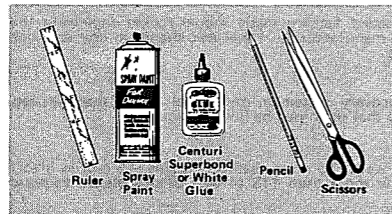

1 Stand the upper and lower body tubes on their fin guides and make fin position marks.

2 Find a convenient channel or groove, such as a door jamb, partially open drawer, or molding. Extend the marks the full length of the tube, to provide fin guide lines.

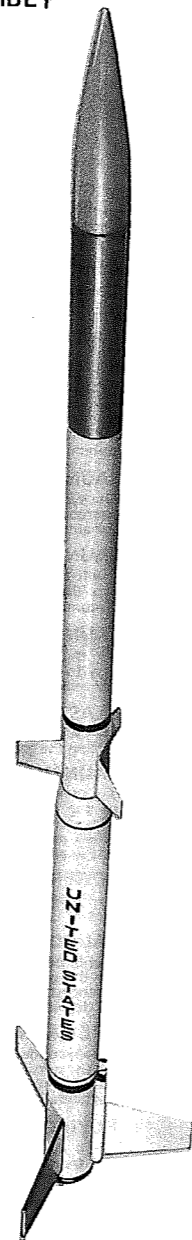
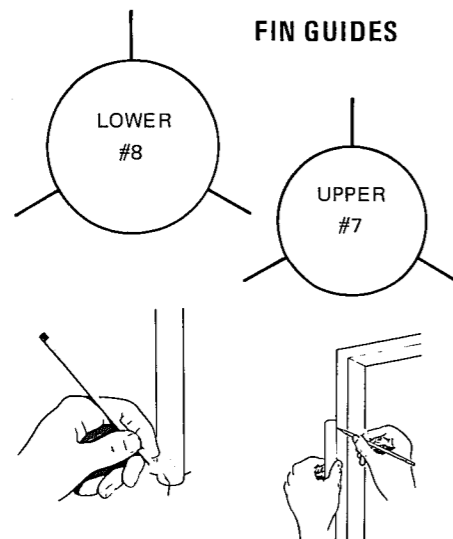

3 The die-cut fibre-fins provided are easy to finish, due to the smooth paper surfaces.

4 Carefully push the die-cut fins from their sheet. Start at one point on each fin and work gently around.

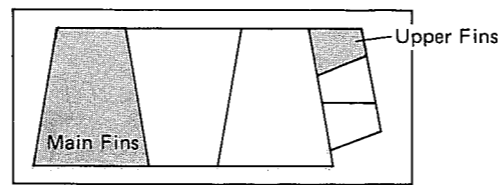

5 Apply a bead of glue to one main fin's root edge and press onto the lower body tube along the drawn line. Remove, allow a minute to become tacky. Add fresh glue to fin, and reposition. Repeat with remaining fins, and fins for upper body tube. Check alignment visually, and allow assemblies to dry standing up-side down.

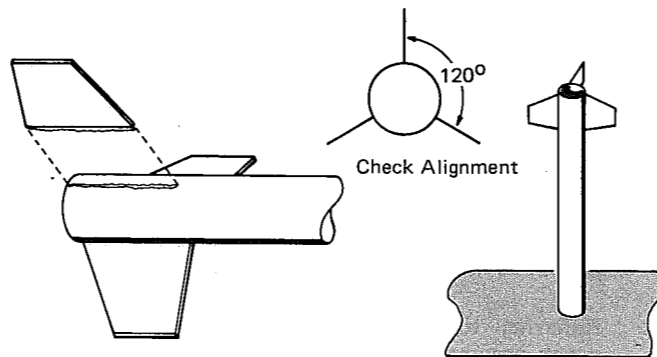

6 Place one end of the engine lock in the pre-cut slot of the 3" engine tube. Apply a bead of glue around the inside of that end. Insert the thrust ring until it butts against the engine lock.

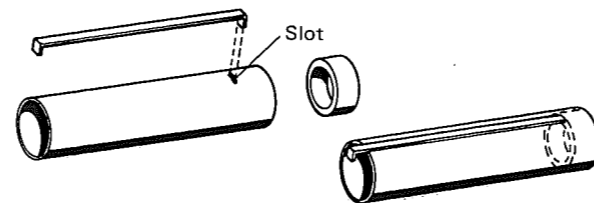

7 Slide the centering ring exactly to position shown. Apply generous beads of glue around each end of the ring and smooth into "fillets" with your finger. Be sure engine lock is parallel with tube.

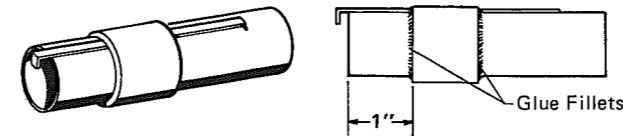

8 NOTE: The basic EXCALIBUR has the chute and shock cord hooked to the nose cone in a standard manner. The plastic reducer is hollow to allow engine ejection gasses to pass through. Note that the reducer has a bar across the smaller end. This allows for an optional assembly technique for easier chute packing, and creates a "payload" ejection. However, it requires at least 4 feet of string (not supplied) to minimize "back-lash" of the upper body rebounding. Remaining steps will show the standard assembly.

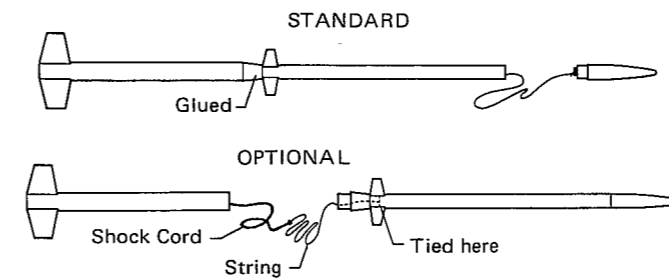

9 Using the pressure-sensitive tabs enclosed will allow for a firm bond of the plastic reducer and paper body tubes, with the same "white" glue used in the rest of the rocket. Simply remove backing and apply 2 tabs firmly around base of larger end and remaining tab around smaller end. NOTE: Joining of body sections may be saved until after painting each different colors, if desired.

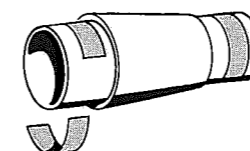

10 When the 2 body assemblies are dry enough to handle, smooth the inside edges of the tubes with thumbnail to remove any burrs. Test fit pieces and remove. Apply a generous bead of glue around inside of each tube. Join tubes to reducer with a firm, even, turning motion.

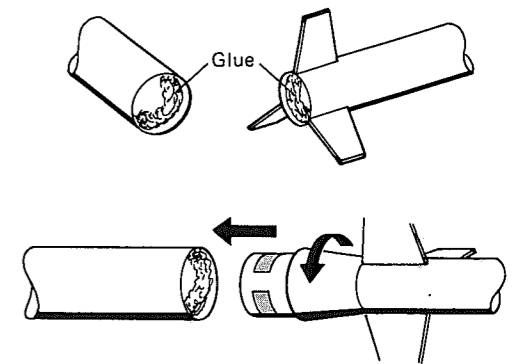

11 Push the plastic insert base into the plastic nose cone until it snaps in place. (Be careful not to break the cone.) Pass one end of the shock cord through the eyelet and tie with a firm knot. Tie the assembled parachute's shroud lines through the eyelet.

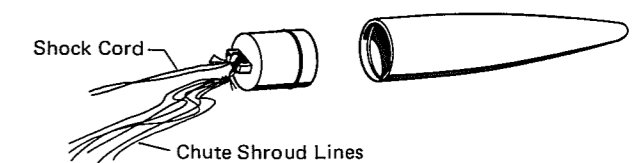

12 Peel the backing from the shock cord fastener. Thread the other end of the elastic shock cord through the fastener as shown. Take care not to touch the adhesive backing any more than absolutely necessary. Slightly crease the fastener lengthwise to allow easy insertion into the tube.

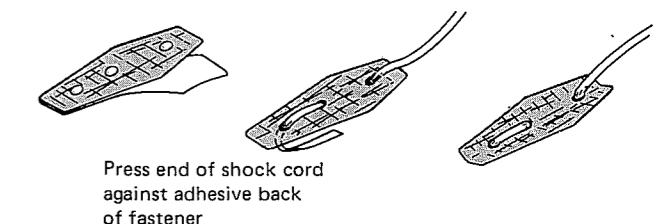

A **B** **C**



DZ-T-WO ST-AT-WS



CAUTION!



EXCALIBUR

M-330

