

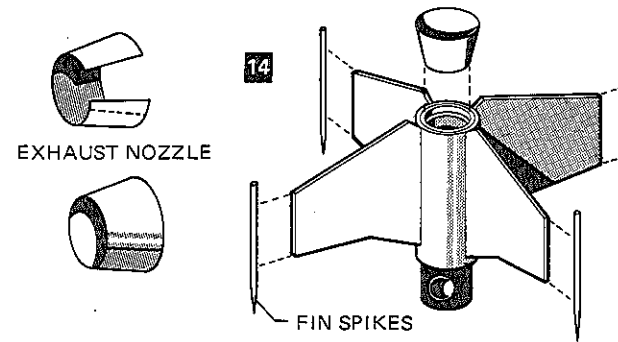

## NOZZLE & FIN SPIKE ASSEMBLY

**14** The Firefly design includes a simulated exhaust nozzle. Carefully cut out the paper nozzle band. So that this band will roll into a complete ring, curl the band by rolling it over a round pencil, pen, or the handle of a modeling knife. Roll the band into a ring and glue ends together as indicated. The Firefly design also includes tip spikes on the booster fins. Glue these spikes to the fin tips as shown.



**15** Tie a short piece of a shroud line around the center of the strands of streamer material. Tie the other end along with the loose end of the shock cord to the nose cone base.

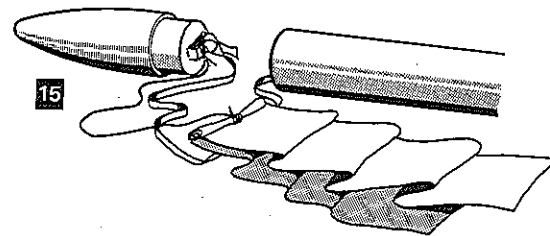

## FINISHING THE FIREFLY

**16** Spray painting your finished model with a fast-drying enamel will produce the best results . . . IF IT IS DONE PROPERLY!!! Most important is the number of coats of paint. DO NOT try to paint your model with one heavy coat! Instead, give it a couple of quick, light coats first, and then a finish coat. Let each coat dry before applying the next . . . gently sanding the fins between coats with very fine sandpaper (400 to 600 grit). DO NOT SAND THE TUBE!

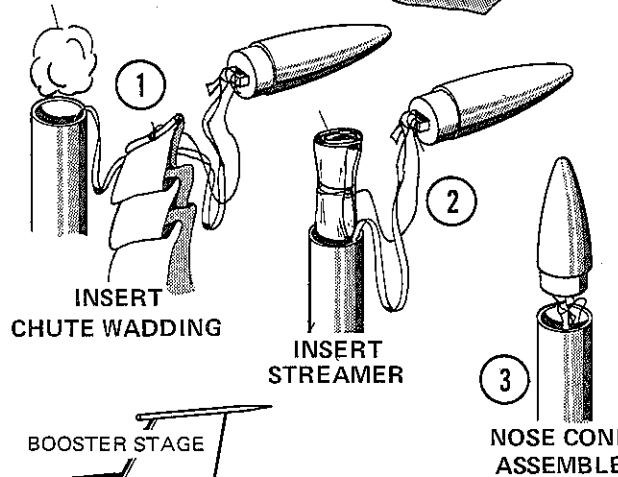

## LAUNCHING THE FIREFLY

**17** The FIREFLY should be launched only with the following engine combination:

BOOSTER (1st Stage)	SUSTAINER (2nd Stage)
½A6-0S	½A6-4S

**18** Prepare the upper stage by inserting flame proof wadding into the top of the main body. Roll and pack the ribbon chute and shock cord into the body and set the nose cone in place.

Wrap the sustainer (upper stage) engine with masking tape and friction fit into the second stage body. Note: The engine must fit tightly to avoid "kickout" when the ejection charge fires. Friction fit the booster engine into the first stage in the same manner. Make sure you insert the nozzle end first.

"Couple" the first and second stages together.

**19** Launch the Firefly from a 1/8" dia. x 36" long launching rod. Use electrical ignition only, as outlined in the engine operating instructions. The following safety checks should be adhered to explicitly:

1. Launch in an open area, well away from main streets, powerlines, pedestrians, traffic, and airport approach paths.
2. Be sure the firing panel is disarmed and battery leads disconnected before wiring up the engine.
3. Check for low flying aircraft before launching.
4. Give a short countdown to alert spectators.
5. Always keep in mind that a model rocket is a scientific instrument, not a toy!

For more information concerning Centuri Model Rocketry Products, see your local hobby dealer. If there is no dealer in your area, you may address inquiries directly to: Centuri Engineering Company, Box 1988, Phoenix, Arizona 85001.

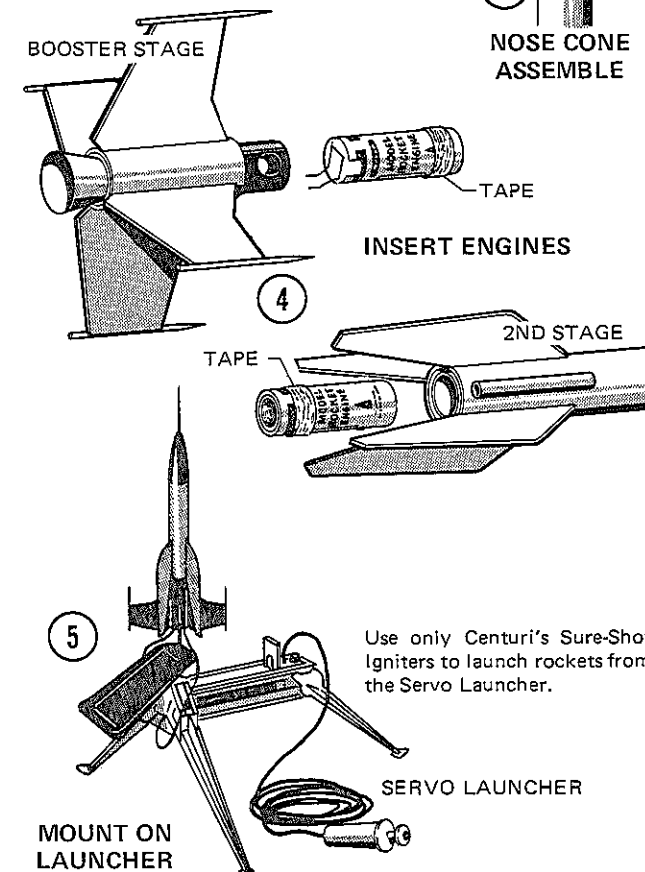

# Centuri Fire Fly

THE WORLD'S SMALLEST  
TWO-STAGE ROCKET!

Catalog No. KA-6

## ASSEMBLY INSTRUCTIONS

FOLLOW DIRECTIONS CAREFULLY!

Only 9" long, the Firefly packs a lot of altitude into a very small package. Centuri's Pass-Port Staging System provides reliable upper stage ignition. The Firefly streaks nearly out of sight, then returns by ribbon chute. The booster tumble recovers. Fly the second stage by itself for excellent single stage flights.

The CENTURI Pass-Port Staging System\* is designed to provide maximum dependability in ignition and separation of multi-stage models. At the same time, it eliminates the need to tape the engines together. Assembly is not difficult, but it must be done correctly.

\*Patent Pending

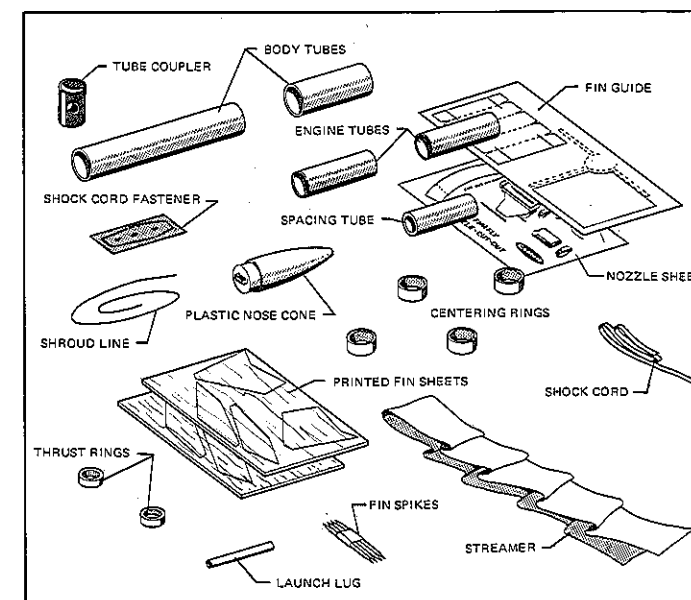
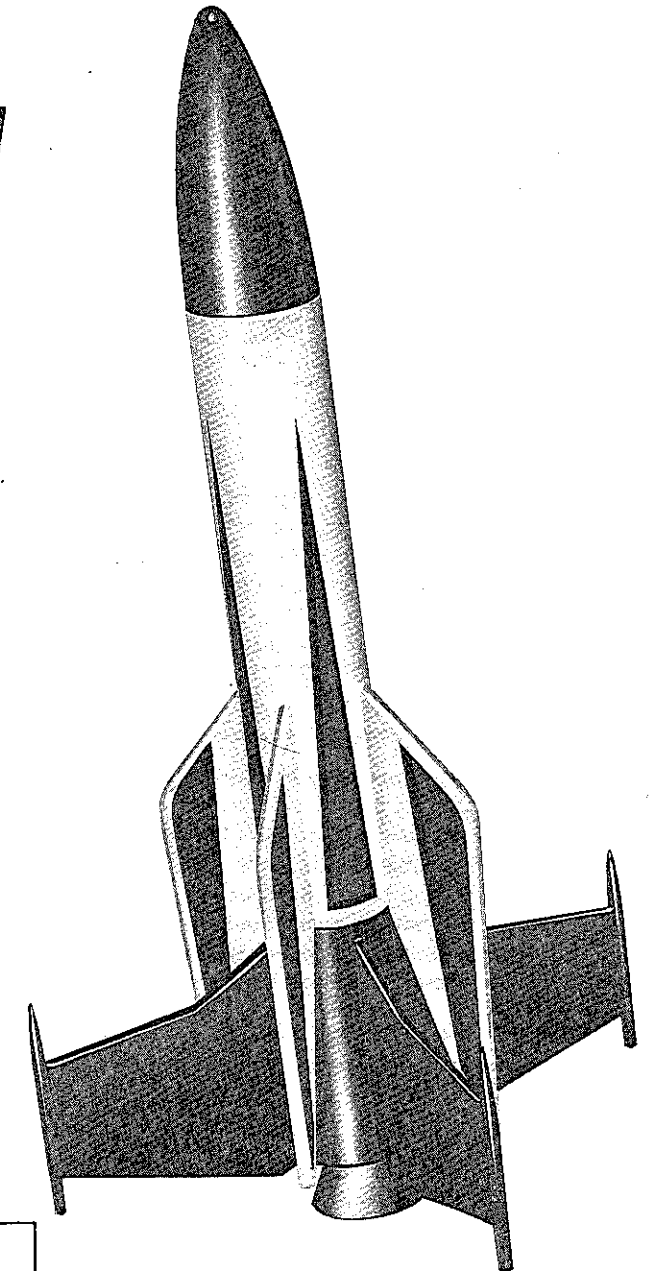

TOOLS: In addition to the parts supplied, you will need the following materials to assemble and finish this kit. DO NOT use model airplane glue for building flying model rockets.

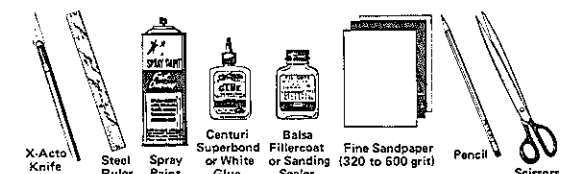

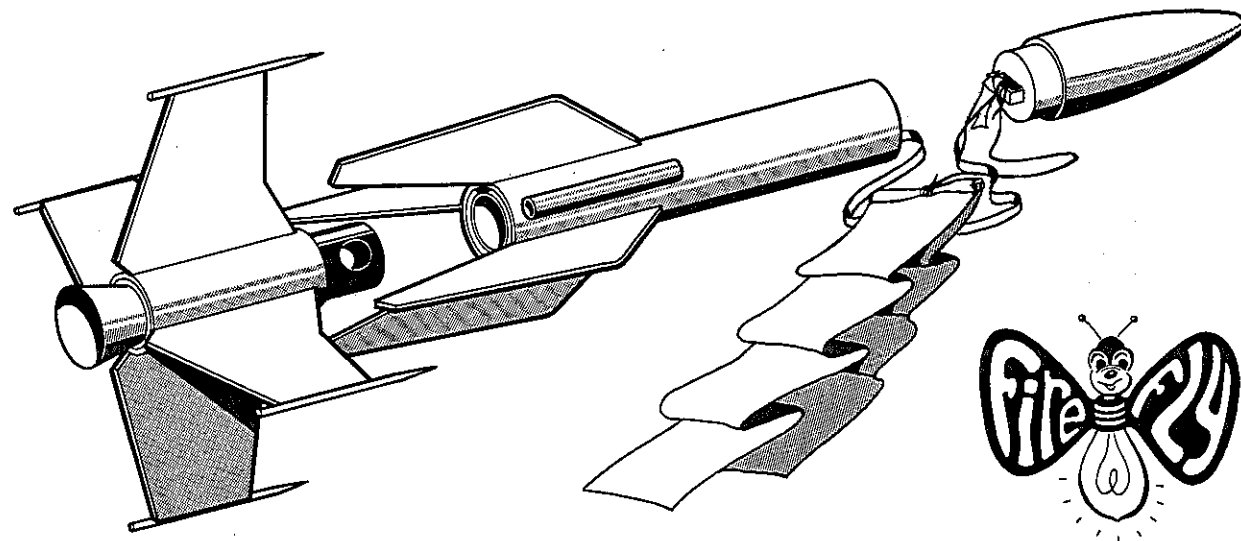

NOTE: Paper tubes and rings are factory cut to exact size. The cutting process leaves a very small flange on the inside portion of the ends of the tubes. These parts are designed to fit within close tolerances. When fitting parts together, lightly sand the inside edges to eliminate the flange. DO NOT force the parts together.

### BOOSTER STAGE ASSEMBLY

- Place the engine spacing tube into an engine tube flush with one end. Place cement on the edges of one thrust ring and insert into the end of the engine tube, butting the thrust ring against the spacing tube. Remove the spacing tube so it will not be accidentally cemented into the engine tube. For added strength, run a bead of glue around the top of the thrust ring.
- Cement one centering ring onto the engine tube, flush with the end in which the thrust ring was fastened. Cement another centering ring in place 1/2" from the opposite end of the engine tube.
- Cement the tube coupler (HTC-7D) onto the end of the engine tube, overlapping it 3/8".
- Place a generous amount of glue on the inside faces of the centering rings. Slip this assembly into the booster body tube until the rear centering is flush with the end of the body tube. Rotate the tube to allow the glue to flow around the centering ring - body tube joints.

### 2ND STAGE ASSEMBLY

- Cement a thrust ring into the other engine tube in the same manner you did on the first stage. Cement one centering ring 1/4" down from the thrust ring end of the body tube. Cement the other centering ring in place 5/8" from the opposite end of the engine tube.

NOTE: Assemble and install shock cord fastener before gluing in 2nd stage engine mount.

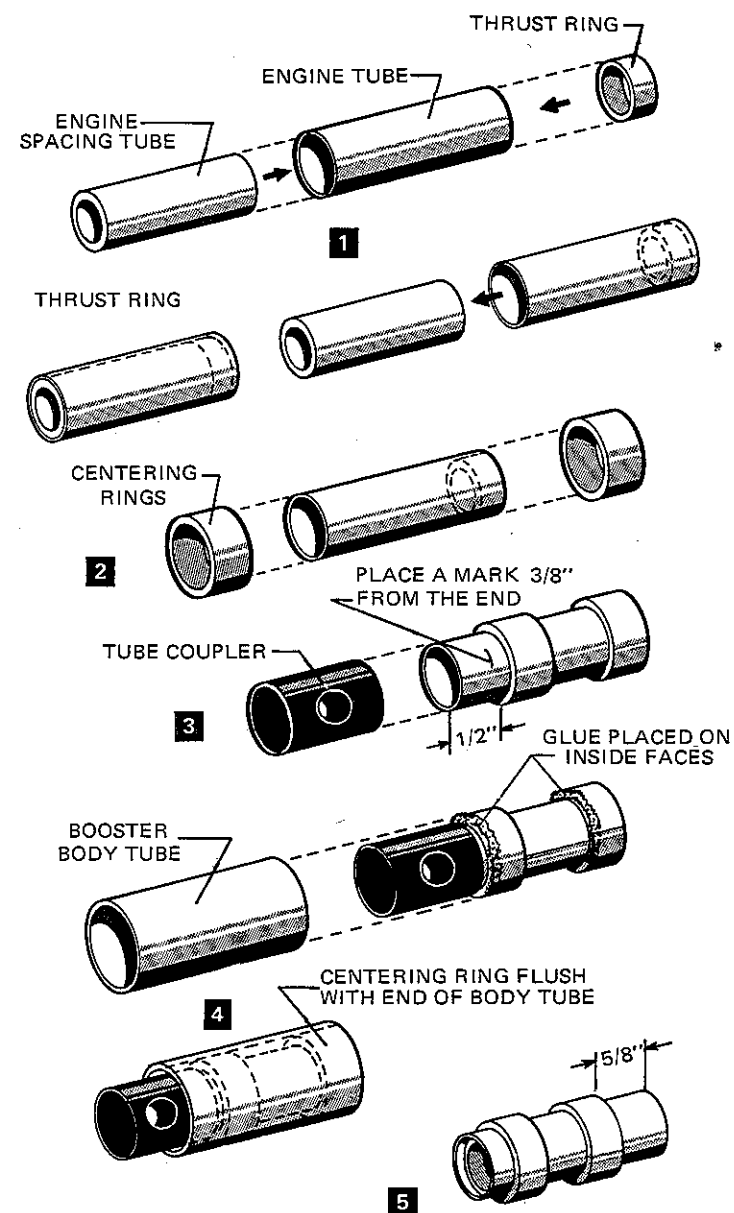

- Peel the backing from the fastener. Thread one end of the elastic shock cord through the fastener as shown. Take care not to touch the backing adhesive any more than absolutely necessary.

Slightly crease the fastener lengthwise (this allows easy access for insertion into tube). Slide the fastener into the top of the body tube and position so the top of the fastener is about 1" below the top of the tube. Press the fastener firmly against the inside wall of the tube with a finger or eraser end of a pencil. NOTE: All edges of the fastener must be firmly contacted to the tube to insure a permanent bond.

- Place glue onto the front faces of the centering rings and insert assembly into the main body tube. The end of the engine tube should be flush with the end of the body tube. Rotate the tube to allow glue to flow into the joints.

### FIN ASSEMBLY

- Carefully cut out fins with a sharp knife. Use a metal ruler as a cutting guide. Square up fin edges with a piece of fine sandpaper. Round the leading edge and taper the trailing edge. Do not round the fin root edge.
- Coat the fins with balsa fillercoat. Allow to dry thoroughly and sand lightly. Repeat the filling and sanding steps until a smooth surface, completely free of grainline, is obtained.
- Wrap the fin positioning guide around the body tubes and mark the fin locations. Using a ruler for a guide, draw lines connecting the marks.
- Apply glue to the fin locations on the body tube and to the root edges of the fins. Press the fins in place, making sure they are parallel with the long axis of the body. Check vertical fin alignment with the fin alignment guide. Set the assembly aside to allow glue to dry.

- After the glue has completely dried, run a bead of glue along both sides of all fin-body tube joints. Using your finger, smooth the glue into even fillets. Glue the launch lug onto the body tube in the position shown.

- Cement the fins onto the booster stage body tube in the same manner as outlined above for the second stage.

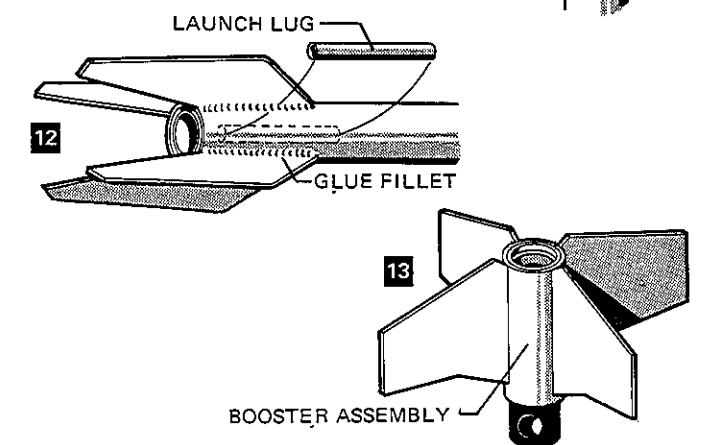
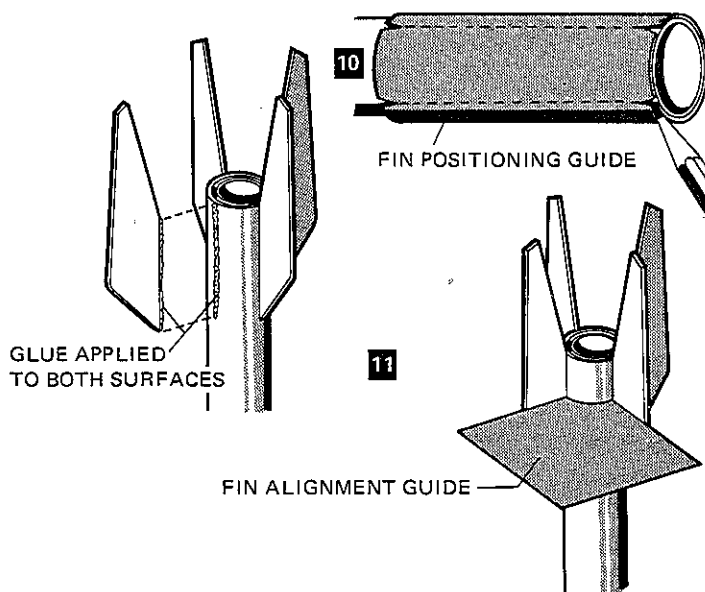
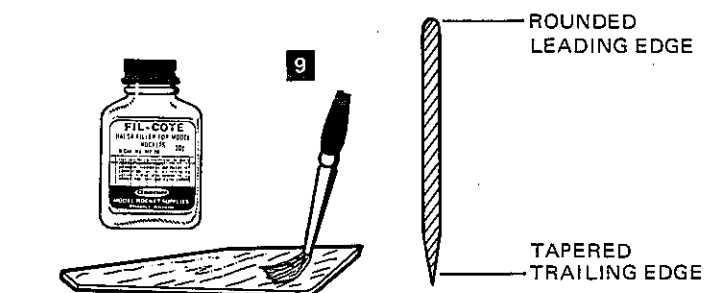
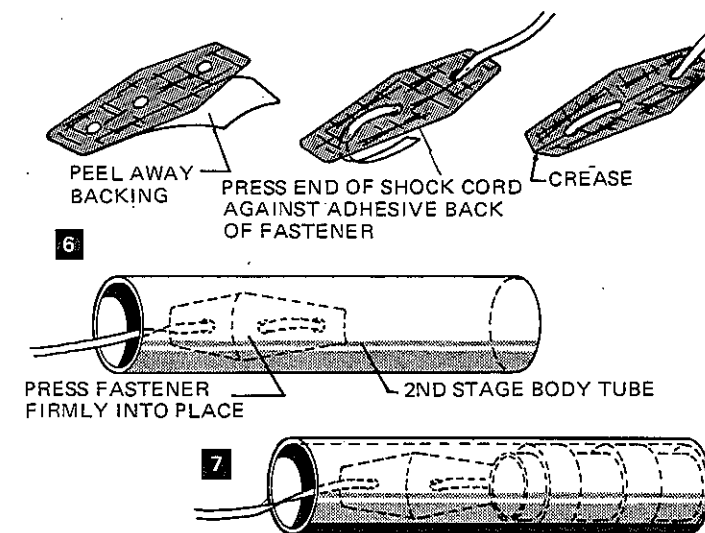

## FIN POSITIONING GUIDE

Cut out on solid line - - - -  
Wrap around body tube base  
tape end flap closed - mark  
fin locations and remove.

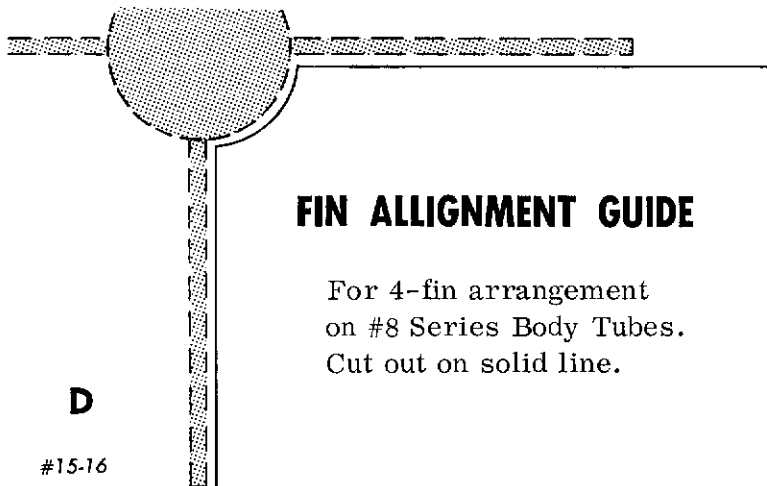

## FIN ALIGNMENT GUIDE

For 4-fin arrangement  
on #8 Series Body Tubes.  
Cut out on solid line.

D

#15-16

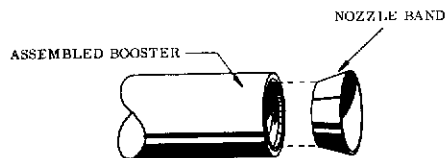
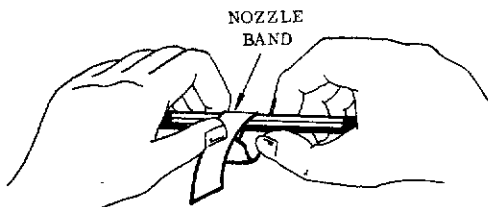
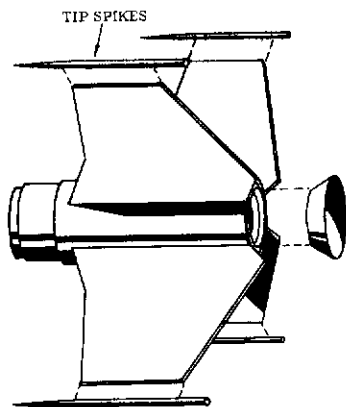
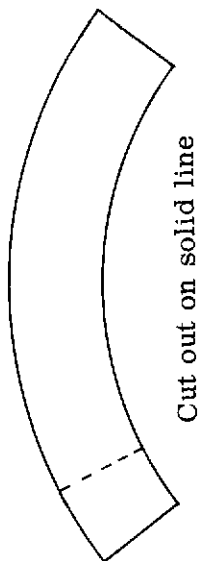

## FIREFLY NOZZLE CUT-OUTS



#15-21

**FIREFLY  
KA-6  
STABILIZER FINS**

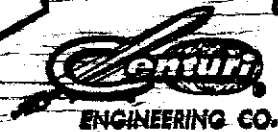

Cut out along this edge  
ROOT CHORD

Cut out along this edge  
ROOT CHORD

Cut Out Balsa Parts Carefully

ROOT CHORD  
Give this edge to body tube  
Cut out with sharp modeling knife

ROOT CHORD  
Give this edge to body tube

The instructions does not list part numbers so here's some notes on the contents:

Body tubes:

1 pc ST-8 x 4 1/2" lg, 1 pc ST-8 x 2" lg.

2 pcs ST-7 x 2" lg.

Plastic 2 piece nose cone, orange with white shoulder plug, 2" lg. from shoulder with 1/2" lg shoulder. The shape is similar to the BC-80 in the '69 catalog.

2 pcs 3/32" balsa fin sheets with 2 booster, 2 sustainer fins printed in blue on each. Both sheets are identical so I only scanned one and did it in B&W to cut file size.

1/8" LL x 1 3/4" lg.

Stage coupler, 1" lg with 2 1/4" holes 180 degrees apart 1/2" from end.

4 centering rings ST-7x8 3/8" lg.

2 ST-7 size engine blocks 3/16" lg.

4 plain old toothpicks

Silver/sticky back shock cord mount.

The instructions are copyrighted 1971.